

# **RF71 Integrated Storage Element Installation Manual**

Order Number EK-RF71D-IM-001

First Edition, January 1989

Copyright ©1989 by Digital Equipment Corporation.  
All Rights Reserved.  
Printed in U.S.A.

The information in this document is subject to change without notice and should not be construed as a commitment by Digital Equipment Corporation.

Digital Equipment Corporation assumes no responsibility for any errors that may appear in this document.

The software, if any, described in this document is furnished under a license and may be used or copied only in accordance with the terms of such license. No responsibility is assumed for the use or reliability of software or equipment that is not supplied by Digital Equipment Corporation or its affiliated companies.

The following are trademarks of Digital Equipment Corporation:

<b>digital</b> ™	EDCS	RSTS
BASEWAY	FMS	RSX
BIBus	MASSBUS	RT
COMPACTape	Micro/RSTS	ThinWire
DEC	MicroPDP-11	UNIBUS
DECconnect	Micro/RSX	VAX
DEC/MAP	MicroVAX II	VAXeluster
DECmate	PDP	VAXstation II
DECnet	P/OS	VAXstation II/GPX
DECUS	Professional	VMS
DECwriter	Q-Bus	VT
DIBOL	Rainbow	

# Contents

---

<b>About This Manual</b>	<b>vii</b>
<b>1 General Information</b>	<b>1</b>
1.1 RF71 ISE Overview . . . . .	1
1.2 The BA213 Enclosure . . . . .	2
1.3 The BA215 Enclosure . . . . .	4
1.4 The R215F Enclosure . . . . .	5
<b>2 Unpacking Information</b>	<b>1</b>
2.1 Unpacking Instructions . . . . .	1
2.2 Inspection . . . . .	3
<b>3 Controls and Indicators</b>	<b>1</b>
3.1 RF71 ISE Switches and LEDs . . . . .	1
3.1.1 DSSI Node ID Select Switches . . . . .	2
3.1.2 READY Indicator . . . . .	2
3.1.3 FAULT Indicator . . . . .	3
3.2 Operator Control Panel (OCP) . . . . .	3
<b>4 Installation Procedure</b>	<b>1</b>
4.1 The BA213 Enclosure . . . . .	1
4.1.1 Opening the Enclosure . . . . .	2
4.1.2 Gaining Access to the Mass Storage Bays . . . . .	4
4.1.3 Installing the Mass Storage Shock Mounts . . . . .	5

4.1.4	Installing the ISE Into the Enclosure . . . . .	7
4.2	The BA215 Enclosure . . . . .	8
4.2.1	Removing the Front Panel . . . . .	8
4.2.2	Gaining Access to the Top Mass Storage Bays . . . . .	9
4.2.3	Installing the RF71 ISE . . . . .	9
4.3	The R215F Enclosure . . . . .	11
4.3.1	Removing the Front Panel . . . . .	11
4.3.2	Gaining Access to the Top Mass Storage Bays . . . . .	12
4.3.3	Gaining Access to the Bottom Storage Bay . . . . .	14
4.3.4	Installing the RF71 ISE . . . . .	15
<b>5</b>	<b>Verification</b>	<b>1</b>
5.1	Verifying the Correct Operation of an ISE . . . . .	1
<b>6</b>	<b>Diagnostics</b>	<b>1</b>
6.1	Power-On Self-Test (POST) . . . . .	1
6.2	Device Resident Diagnostics . . . . .	2
6.2.1	DIRECT . . . . .	3
6.2.2	DRVSTST . . . . .	3
6.2.3	DRVEXR . . . . .	4
6.2.4	HISTORY . . . . .	6
6.2.5	ERASE . . . . .	8
6.3	Diagnostic Error Codes . . . . .	9
<b>7</b>	<b>The PARAMS Utility</b>	<b>1</b>
7.1	Invoking PARAMS . . . . .	1
7.2	HELP . . . . .	2
7.3	SET . . . . .	2
7.4	SHOW . . . . .	4
7.5	STATUS . . . . .	5
7.6	WRITE . . . . .	6
7.7	EXIT . . . . .	6

## Figures

1-1	The RF71 Integrated Storage Element . . . . .	2
1-2	The BA213 Enclosure . . . . .	3
1-3	The BA215 Enclosure . . . . .	4
1-4	R215F Configuration (Example) . . . . .	5
2-1	RF71E-SF Option Kit . . . . .	2
3-1	RF71 ISE Switch and LED Locations . . . . .	1
3-2	BA200-Series Operator Control panel for DSSI ISEs . . . . .	4
4-1	The BA213 Enclosure with DSSI ISEs . . . . .	2
4-2	BA213 Front Cover Removal . . . . .	3
4-3	Removing the Media Faceplate and OCP . . . . .	4
4-4	Attaching the Metal Ground Strip . . . . .	6
4-5	Installing the Slide Rails . . . . .	7
4-6	DSSI Bus, Power, and OCP Connectors . . . . .	10
4-7	Removing the Top Media Faceplate . . . . .	12
4-8	R215F Shipping Bracket Screws . . . . .	13
4-9	Removing the Bottom Media Faceplate . . . . .	14

## Tables

2-1	Parts List for the RF71E-SF Option Kit . . . . .	3
3-1	DSSI Node ID Selection . . . . .	2
3-2	Description of OCP Indicators and Switches . . . . .	5
7-1	Valid PARAMS Commands . . . . .	1
7-2	Summary of SET and SHOW User Parameters . . . . .	3
7-3	Types Available to the STATUS Command . . . . .	5



# About This Manual

---

This manual provides information and procedures for installing the RF71 integrated storage element (ISE) into the BA213, BA215 and R215F enclosures.

## **Intended Audience**

This document is intended for Digital Field Service personnel or qualified self-maintenance customers only.

## **For the Customer**

The RF71 ISE is intended for use in systems with either a KA640 CPU or Digital Storage System Interconnect (DSSI) adapter, such as the KFQSA adapter, installed.

It is the customer's responsibility to perform a software backup prior to the arrival of Digital Field Service personnel at the site. This step is important to ensure data is not lost during any installation process.

If you are not qualified to install the RF71 ISE, call Digital Field Service to schedule an installation.

To install the RF71, follow the instructions and procedures for your system outlined in this manual. If you have any difficulty performing the installation, call Digital Field Service for assistance.

Customers may order additional documents from:

Digital Equipment Corporation  
Peripherals and Supplies Group  
P.O. Box CS2008  
Nashua, NH 03081

### **For Field Service**

The RF71 ISE can be used on any MicroVAX system that has a DSSI storage adapter installed. The procedures in this manual can be followed if an adapter and all necessary DSSI cabling are in place. Refer to your system or adapter installation manual for instructions on installing, configuring, and cabling a DSSI subsystem.

To install the RF71 ISE, follow the installation procedures for the appropriate system outlined in this manual. When you have completed the installation, submit a labor activity reporting system (LARS) form. For installation on completing this form, contact your unit manager.

Digital personnel may order hardcopy documents from:

Digital Equipment Corporation  
444 Whitney Street  
Northboro, MA 01532  
Attn: Publishing and Circulation Services  
(NR03/W3) Order Processing Section

# 1

## General Information

---

This chapter describes the RF71 integrated storage element (ISE) and the enclosures into which it can be installed.

All installations should be documented using LARS. The correct system name, option name, and serial numbers should be recorded for proper installation tracking.

### 1.1 RF71 ISE Overview

The RF71 ISE ([Figure 1-1](#)) is a full-height, 5-1/4-inch fixed disk mass storage device. It is one of a family of storage devices based on the Digital storage architecture (DSA) utilizing the DSSI bus and interface. The term integrated storage element (ISE) refers to the fact that the RF71 has embedded within it an intelligent controller and Mass Storage Control Protocol (MSCP) server.

DSSI devices support up to seven ISEs daisy chained through a single cable to an adapter in the host. DSSI adapters can be adapters embedded within a CPU module (for example the KA640 module) or non-embedded modules, such as the KFQSA adapter.

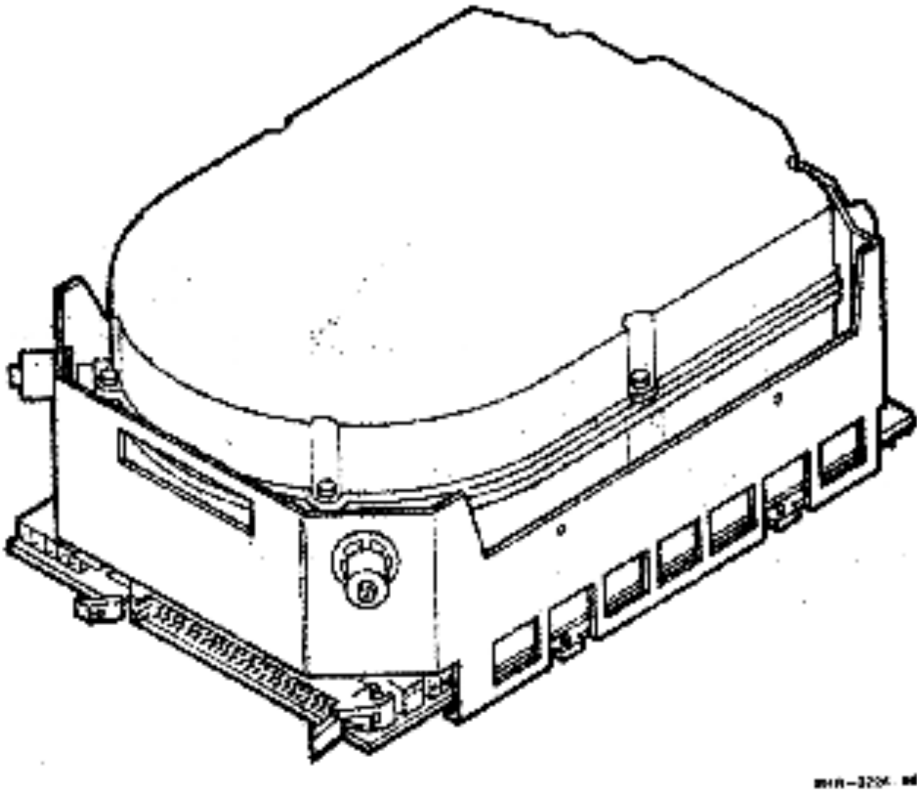
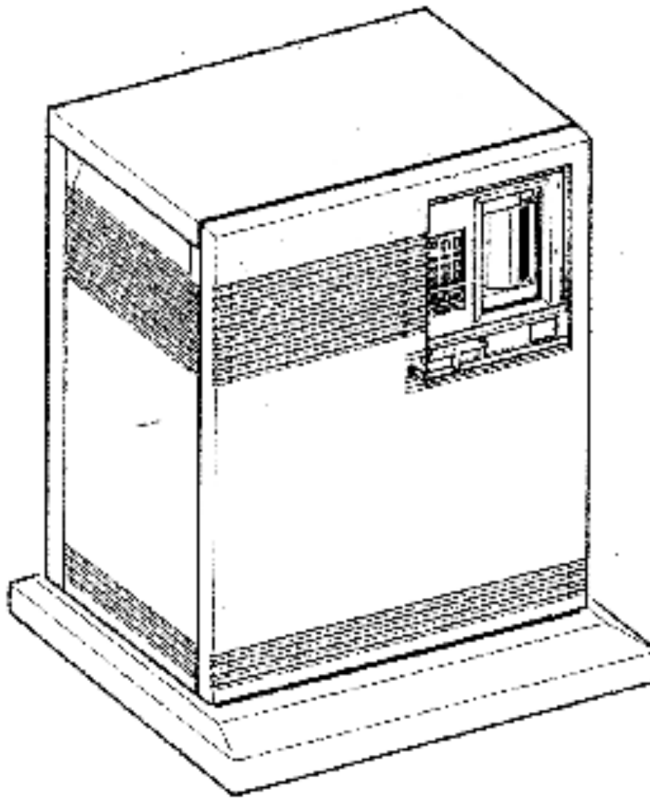

Figure 1-1: The RF71 Integrated Storage Element

## 1.2 The BA213 Enclosure

The BA213 enclosure (Figure 1-2) has a mass storage bay above the card cage that contains either a TK70 tape drive or a TK50 tape drive, and up to three DSSI ISEs.

Mass storage devices are mounted sideways on shock-mounting hardware with a sliding track attached to each side of the device. One shock-resistant support attaches to the top of the mass storage, and the other support attaches to the bottom of the device. The supports are attached by two screws enclosed in rubber shock bushings. The shock-mounting hardware is different for each ISE model that can be installed.



ENC-0019 AM

**Figure 1-2: The BA213 Enclosure**

## 1.3 The BA215 Enclosure

EK-RF71D-IM-001.tex The BA215 enclosure (Figure 1-3) has a mass storage bay that extends across the top of the enclosure. It contains a TK70 tape drive or TK50 tape drive, and either one or two ISEs.

Mass storage devices are mounted sideways on shock-mounting hardware, with a sliding track attached to each side of the device. One shock-resilient support attaches to the top of the mass storage area, and the other support attaches to the bottom of the device. The supports are attached by two screws enclosed in rubber shock bushings. The shock-mounting hardware is different for each ISE model that can be installed.

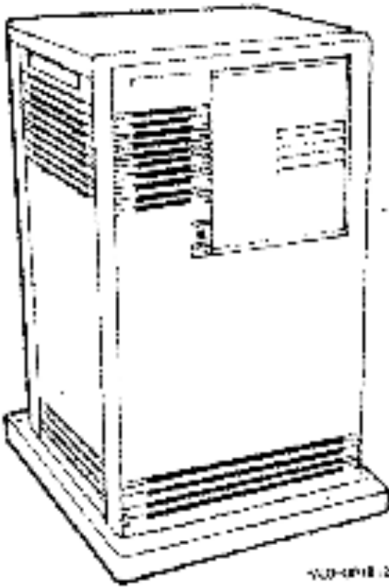
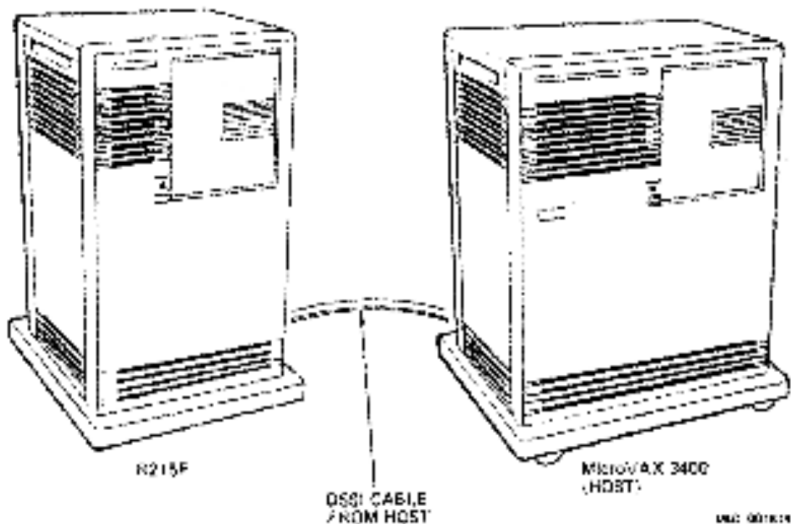

Figure 1-3: The BA215 Enclosure

## 1.4 The R215F Enclosure

The R215F enclosure is a BA215 enclosure with the card cage removed and an additional mass storage bay. It has three mass storage bays: two bays in the top of the cabinet, and a third bay in the middle of the cabinet. Each mass storage bay can hold one 13.3 cm (5.25-inch) ISE. [Figure 1-4](#) is a typical RF215 configuration that includes an RF215F expansion enclosure and a MicroVAX 3400 in a BA213 enclosure.

Mass storage devices are mounted sideways on shock-mounting hardware with a sliding track attached to each side of the device. One shock-resistant support attaches to the top of the mass storage are, and the other support attaches to the bottom of the device. The supports are attached by two screws enclosed in rubber shock bushings. The shock-mounting hardware is different for each ISE model installed.



**Figure 1-4: R215F Configuration (Example)**



# 2

## Unpacking Information

---

Unpacking the RF71 ISE consists of removing it from the shipping container and inspecting for damage. Report any damage to the shipper and notify your Digital representative.

### 2.1 Unpacking Instructions

1. Before opening any container, check for external damage such as dents, holes, or crushed corners.
2. Open and unpack the shipping container. Remove the ISE from the conductive plastic bag.

#### **CAUTION**

When handling the RF71 ISE, observe all precautions to be sure that you do not damage the device by accidental electrostatic discharge.

#### **NOTE**

Shipping containers and packing materials should be retained for possible future use.

[Figure 2-1](#) illustrates all the parts included in the RF71E-SF Option Kit.

## 2-2 Unpacking Information

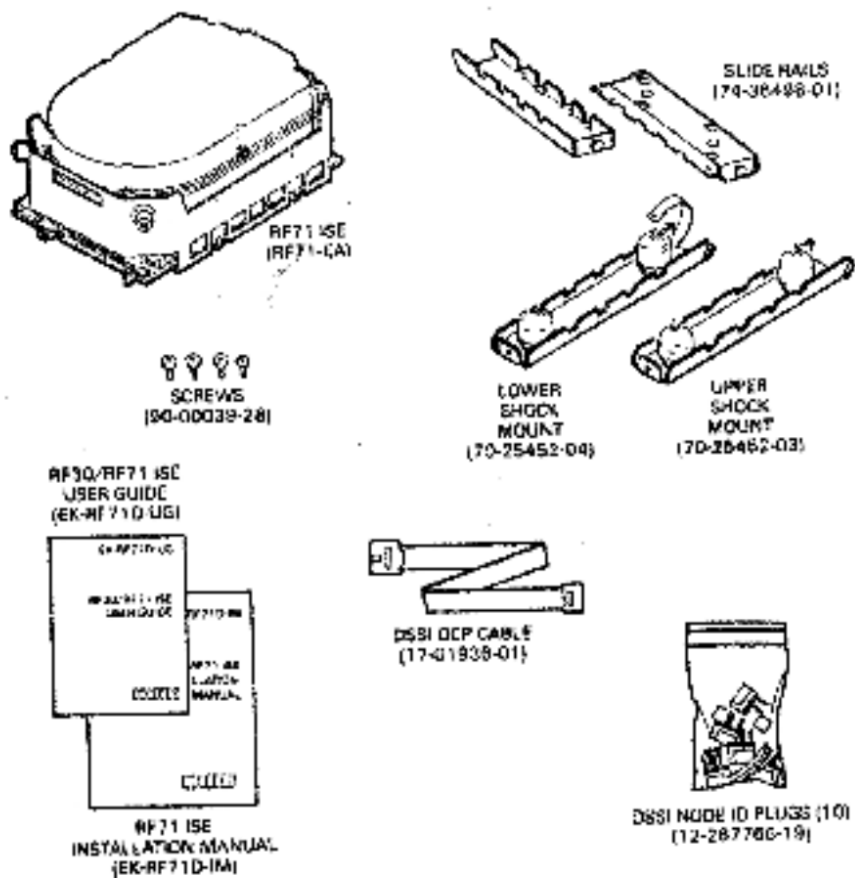

© 2014 Cisco and/or its affiliates. All rights reserved. Cisco Confidential

Figure 2-1: RF71E-SF Option Kit

## 2.2 Inspection

1. Inspect the RF71 ISE for physical damage.
2. Check the contents against the bill of materials. Table 2-1 lists the parts supplied with the RF71E-SF (field installed) option kit.

**Table 2-1: Parts List for the RF71E-SF Option Kit**

Part Number	Quantity	Description
RF71-SA	1	RF71-AA (ISE without skid plate)
70-25452-03	1	Upper shock mount
70-25453-04	1	Lower shock mount
74-35498-01	2	Slide rails
90-00039-28	4	Slide rail mounting screws
17-01936-01	1	DSSI OCP cable (10-conductor)
12-267766-19	10	DSSI node ID plugs
EK-RF71D-IM	1	RF71 ISE Installation Manual
EK-RF71D-UG	1	RF30/RF71 ISE User Guide

## 2-4 Unpacking Information

# 3

## Controls and Indicators

---

This chapter describes the controls and indicators for the RF71 ISE.

### 3.1 RF71 ISE Switches and LEDs

Figure 3-1 shows the location of the switches and LEDs on the RF71 ISE.

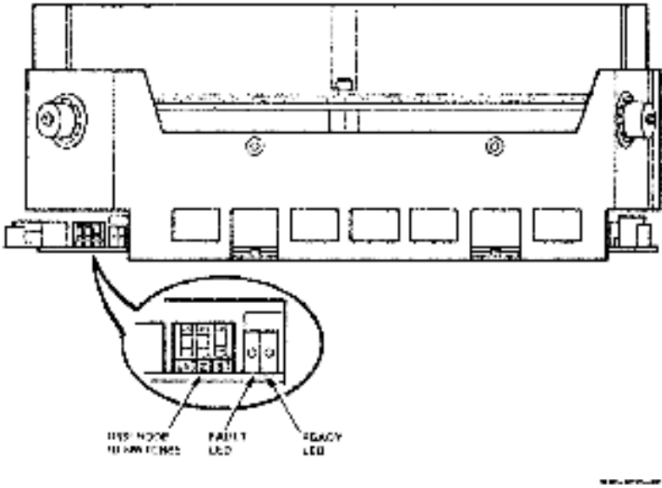

Figure 3-1: RF71 ISE Switch and LED Locations

### 3.1.1 DSSI Node ID Select Switches

The RF71 ISE had a DIP switchpack located next to the DSSI connector that is used to assign a DSSI node ID number to the ISE. Each device on the DSSI bus must be assigned a unique node IDE between zero and seven.

Assignment of the DSSI node ID is made during installation by setting the 3-position DIP switch to the binary equivalent of the desired ID number (see [Table 3-1](#)).

**Table 3-1: DSSI Node ID Selection**

DSSI Node Address	Switch Positions <sup>1</sup>		
	Switch 1	Switch 2	Switch 3
0	Down	Down	Down
1	Down	Down	Up
2	Down	Up	Down
3	Down	Up	Up
4	Up	Down	Down
5	Up	Down	Up
6	Up	Up	Down
7 <sup>2</sup>	Up	Up	Up

<sup>1</sup>Up is toward the HDA, down is toward the module.

<sup>2</sup>Normally assigned to a host node.

#### NOTE

These switches are ignored by the RF71 ISE when it is connected to an operator control panel. In this case, use the OCP controls described in [Section 3.9](#) to select the DSSI node ID.

### 3.1.2 READY Indicator

This indicator is a green LED. When the ISE is powered up, this indicator is turned on. After successful completion of the power-on self-test (POST), the indicator is turned off until the ISE is read/write ready.

The READY LED is turned off during a seek until the drive heads are on a cylinder and read/write ready. Then the indicator is turned on again for as long as the heads remain on track. Thus, during read or write operations, the indicator flickers on and off rapidly.

### 3.1.3 FAULT Indicator

This indicator is a red LED. It is turned on when a read/write error or serious physical error condition is detected. Initially, when the ISE is powered up, this indicator is turned on. Upon successful completion of POST, this indicator is turned off.

## 3.2 Operator Control Panel (OCP)

When the RF71 ISE is installed in a BA213, BA215 or R215F enclosure, the operator interface is a control panel on the enclosure. [Figure 3-2](#) shows the OCP. Its functions are described in Table 3-2. Each RF-series ISE is connected to the OCP through a 10-conductor ribbon cable.

The OCP has three columns of controls and indicators. The standard convention is to use the right column for ISE 0, the center column for ISE 1, and the left column for ISE 2. Note, however, that the DSSI node IDE address is determined by the drive select plug rather than its position on the OCP. The address that will be assigned to the ISE is labeled on the plug.

### NOTE

The DSSI address assigned by the plug is read only during the power-up sequence. If you change the plugs without reinitialising the ISE by a power-up or reset, the new DSSI address is not recognised.

### CAUTION

Do not install two plugs with the same number on the OCP.

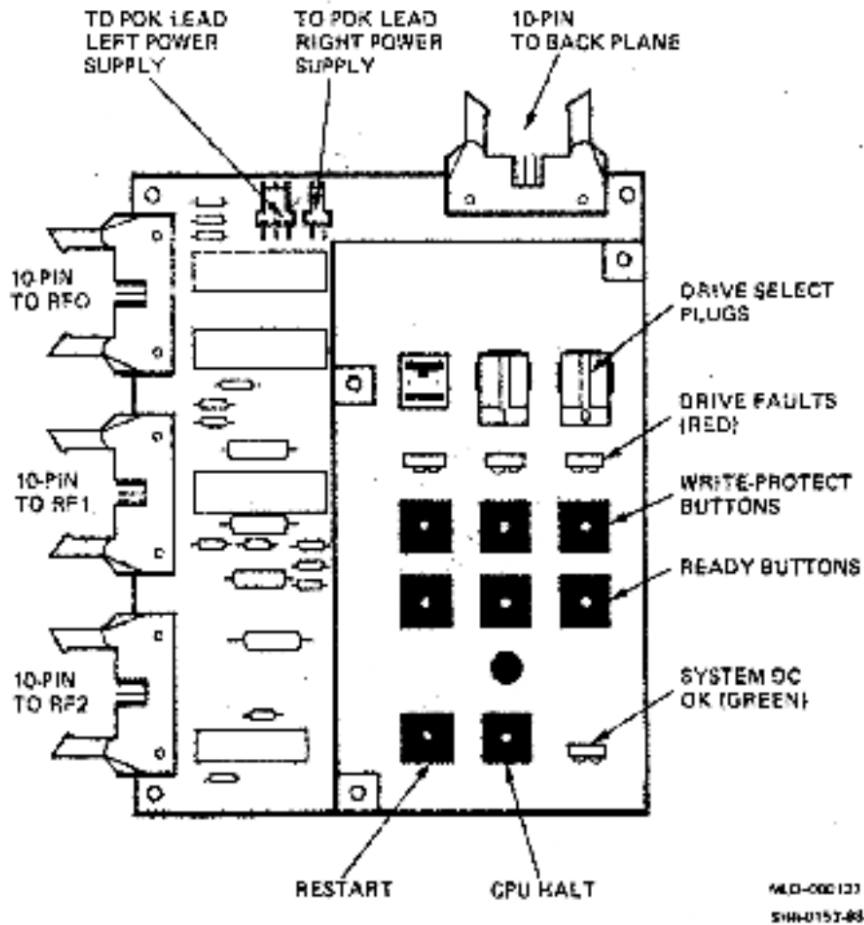

Figure 3-2: BA200-Series Operator Control panel for DSSI ISEs

**Table 3-2: Description of OCP Indicators and Switches**

Control/ Indicator	Setting	Function
System	On	DC power is within regulation.
DC OK	Off	DC power not present or not within regulation.
Drive Select Plug	Installed	Sets DSSI node ID to the number specified on the plug (normal operating position). Plug must be installed if ISE is connected to OCP.
	Removed	DSSI address undefined. If ISE is present, Fault LED flashes rapidly.
Fault LED	On	Fault condition is present.
	Off	No fault (normal operating condition).
	Flashing	Module-to-HDA calibrations are being performed.
Write- Protect	Flashing	OCP failure or drive select plug missing.
	Out LED off	The system can read and write to the disk (normal operating position)
Ready	In LED on	The system cannot write to the disk. The system can still read from the disk.
	Out LED on	ISE is on-line (normal operating position). The system can read from and write to the disk.
	In LED off	ISE is off-line. The system cannot read from or write to the disk.
CPU Halt	In LED on	The CPU is in console IO mode. The console emulation program is running.
	Out LED off	The CPU can run system software (normal operating position).
Restart	Pressed	Reinitialises system state. Work in progress is lost.



# 4

## Installation Procedure

---

This chapter explains how to install the RF71 ISE into a BA200 Series enclosure.

### **CAUTION**

**Only qualified service personnel should attempt this installation procedure. Before beginning the installation, make sure that the system manager has backed up all files. Have the system manager perform a shutdown of the operating system before turning the power off.**

### **4.1 The BA213 Enclosure**

The BA213 enclosure holds up to three RF71 ISEs and a tape storage device. [Figure 4-1](#) shows a standard DSSI configuration in a BA213 enclosure.

To install an RF71 ISE in the BA213 enclosure, use the following procedure. This procedure is written on the assumption that either a KA640 module or a KFQSA adapter module is already installed in the system, and that DSSI cabling is in place. Refer to your system or adapter documentation for instructions on installing these devices.

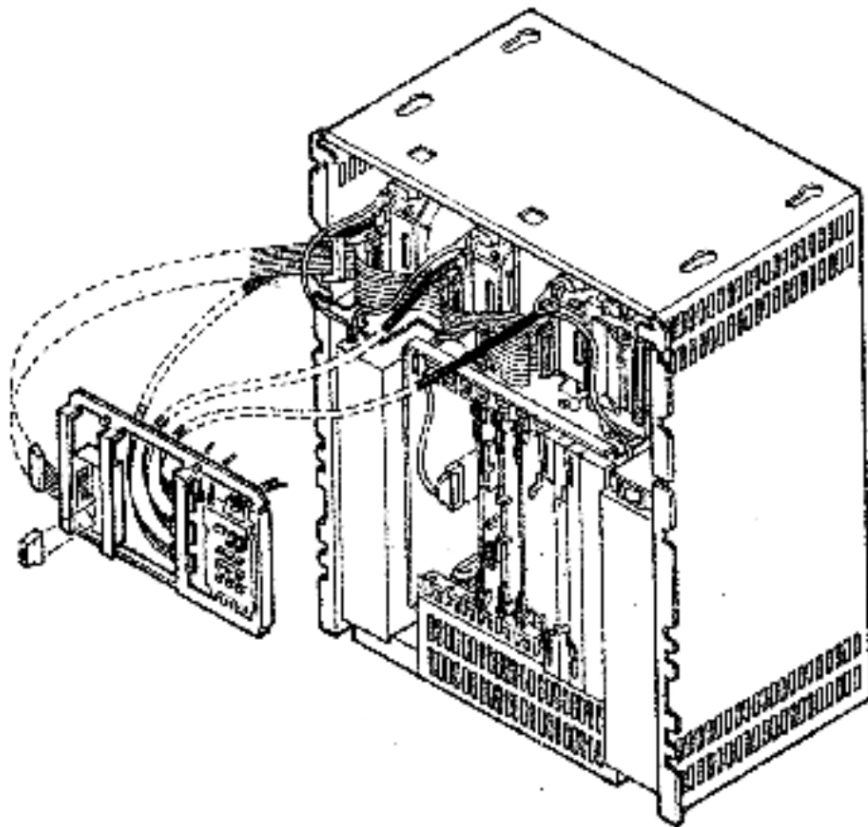

Qty 0021-98

**Figure 4-1: The BA213 Enclosure with DSSI ISEs**

### **4.1.1 Opening the Enclosure**

The front door has a 3-position lock that limits access to system controls. The controls are located behind a plastic window at the upper right of the cover ([Figure 4-2](#)). Open the door as follows:

1. Insert the key into the lock on the front door. Turn the key to the bottom position (fully clockwise).

2. Slide the window all the way down.
3. Turn the  power switch off (to the right) and unplug the ac power cord from the wall outlet.
4. Pull the release latch outward and use the latch as a hand grip to lift the front door and remove it from the system ([Figure 4-2](#)).

**CAUTION**

Do not use a screwdriver or other tool to pry open the release latch as this may damage the latch.

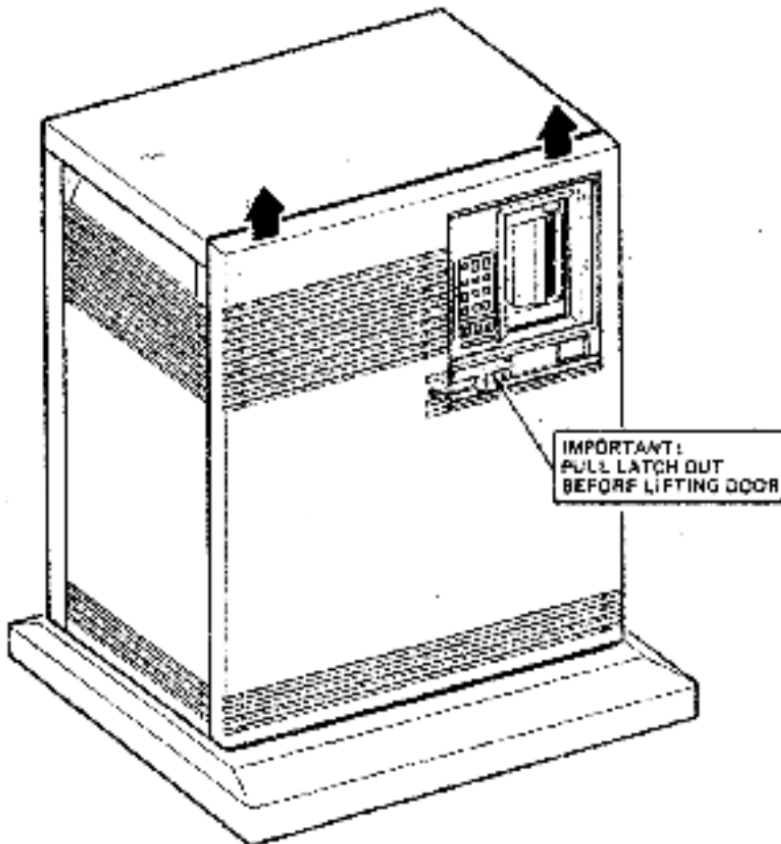

L119 0001-05

Figure 4-2: BA213 Front Cover Removal

## 4.1.2 Gaining Access to the Mass Storage Bays

1. Remove the media faceplate from the front panel of the mass storage bays by releasing the five captive screws and pulling the cover forward (Figure 4-3).
2. Remove the two screws from the top of the OCP chassis and lift the OCP out of the enclosure.

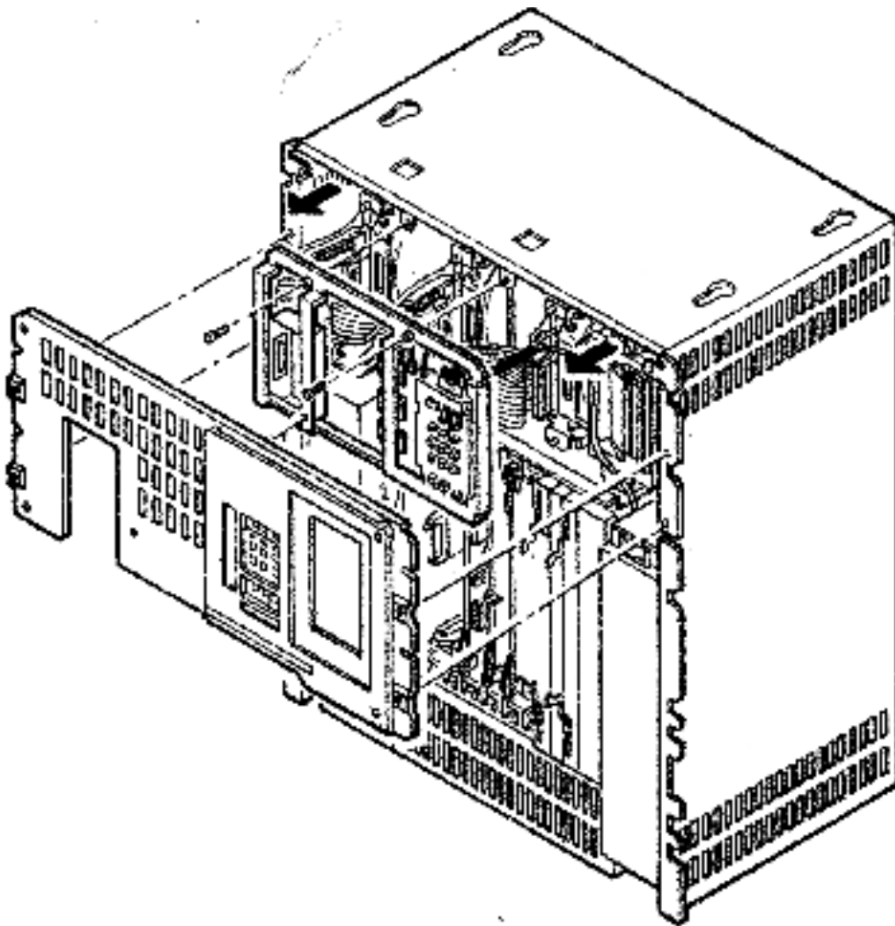

544 2678 08

Figure 4-3: Removing the Media Faceplate and OCP

### 4.1.3 Installing the Mass Storage Shock Mounts

Install the upper and lower shock mounts in the mass storage bay using the following procedure:

#### **CAUTION**

**Make sure to install the shock mounts shipped with the option kit. Check the part number against Table 2-1. Installing the wrong shock mounts may result in damage to the ISE.**

1. Carefully disconnect any cables that are in the way and mark them for reinstallation later.
2. Make sure the metal shipping brackets are in the released position. Instructions for releasing the shipping brackets are printed on a sticker attached to the front of the OCP.

#### **CAUTION**

**Release the shipping brackets before operating the ISEs or they may be damaged.**

3. Using a short flat-head screwdriver, attach the top bracket assembly to the screw holes in the top of the appropriate mass storage bay. Make sure the open end of the bracket is facing the rear of the mass storage area.
4. Holding the bottom bracket assembly, place the hole on the metal grounding strip located on the rear of the assembly over the exposed threads of the rear screw ([Figure 4-4](#)).
5. Using a short flat-head screwdriver, attach the bottom bracket assembly to the two screw holes in the bottom of the appropriate mass storage area. Make sure the open end of the bracket is facing the rear of the mass storage area.

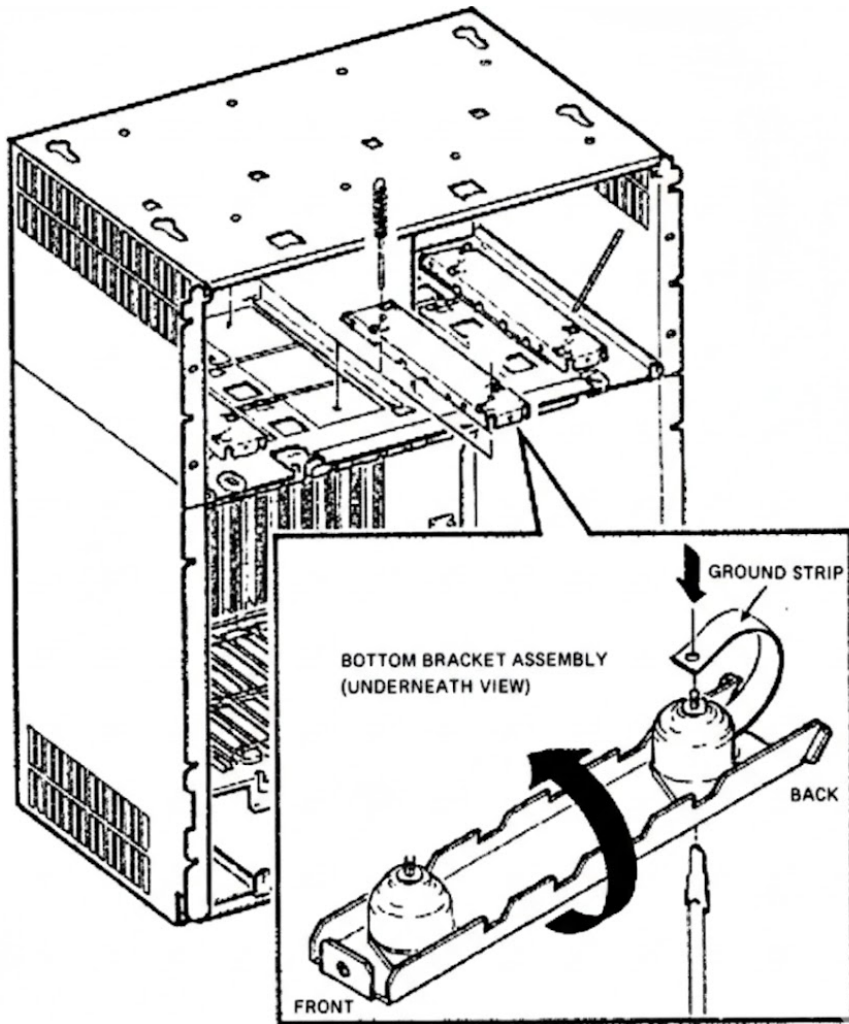

VA-6638-01

Figure 4-4: Attaching the Metal Ground Strip

#### 4.1.4 Installing the ISE Into the Enclosure

##### CAUTION

The RF71 ISE is susceptible to electrostatic damage. Do not handle it unless you are wearing an antistatic wrist strap that is properly grounded to the system cabinet. When you have removed the ISE from its shipping container, place it on an antistatic pad. Use the static-protective Field Service kit (PN 29-26246).

1. Install the slide rails using the four screws provided (Figure 4-5).

##### CAUTION

Make sure you use the screws provided. Longer screws may damage the ISE.

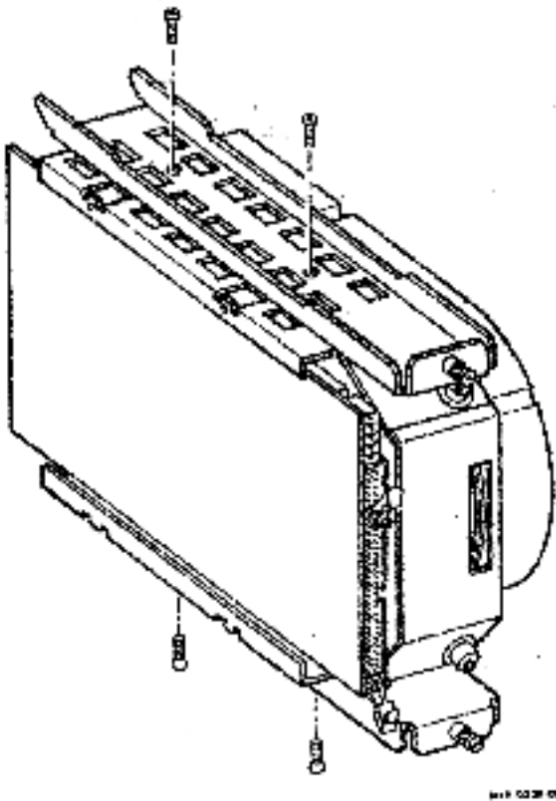

Figure 4-5: Installing the Slide Rails

## 4-8 Installation Procedure

2. Slide the ISE into the mass storage bay (drive module to the left) and hand tighten the slide rail screws.
3. Connect the power cable to the ISE.
4. Use the 10-conductor cable provided to connect the ISE to the OCP.
5. Connect the DSSI cable to the ISE.
6. Replace the OCP and the media faceplate.
7. Install the correct drive select plug on the OCP.

## 4.2 The BA215 Enclosure

The BA215 enclosure holds one or two RF71 ISEs and a TK70 tape drive or TK50 tape drive.

### 4.2.1 Removing the Front Panel

The front panel has a 3-position lock that limits access to the system controls. The controls are located behind a plastic window at the upper right of the cover.

Remove the front panel as follows:

1. Insert the key into the lock on the front door. Turn the key to the bottom position (fully clockwise).
2. Slide the window all the way down.
3. Turn the  power switch off (to the right) and unplug the ac power cord from the wall outlet.
4. Pull the release latch outward and use the latch as a hand grip to lift the front door and remove it from the system.

### CAUTION

**Do not use a screwdriver or other tool to pry open the release latch as this may damage the latch.**

## 4.2.2 Gaining Access to the Top Mass Storage Bays

### CAUTION

Static electricity can damage integrated circuits. Use an antistatic wrist strap and mat when performing this procedure.

1. Release the four captive screws that hold the media faceplate to the BA215 frame and remove the faceplate.
2. Remove the screw from the top of the OCP chassis and lift the OCP out of the enclosure.
3. The shipping brackets inside the mass storage area(s) should have been released during installation of the unit. If they were not released, make sure the four orange plain-slotted screws are loosened to release the shipping brackets. Retighten the screws against the frame after the brackets are released.

### CAUTION

Failure to release the shipping brackets prior to use may result in damage to the ISEs.

4. Remove the terminator and DSSI cable.

## 4.2.3 Installing the RF71 ISE

### CAUTION

The RF71 ISE is susceptible to electrostatic damage. Do not handle it unless you are wearing an antistatic wrist strap that is properly grounded to the system cabinet. When you have removed the ISE from its shipping container, place it on an antistatic pad. Use the static-protective Field Service kit (PN 29-26246).

1. Install the upper and lower shock mounts in the mass storage bay using the procedure outlined in [Section 4.1.3](#).

### CAUTION

Make sure you install the shock mounts shipped with the devices. Check the part number against Table 2-1. Installing the wrong shock mounts may result in damage to the ISE.

## 4-10 Installation Procedure

2. Install the slide rails using the four screws provided (see [Figure 4-5](#))

### CAUTION

**Make sure you use the screws provided. Longer screws may damage the ISE.**

3. Slide the ISE into the mass storage bay (drive module to the left) and hand tighten the slide rail screws.
4. Connect the power cable to the power connector on the ISE (see [Figure 4-6](#)).
5. Use the 10-conductor cable provided to connect the ISE to the OCP.
6. Connect the DSSI cable to the DSSI connector on the ISE.
7. Replace the OCP and the media faceplate.
8. Install the correct drive select plug on the OCP.

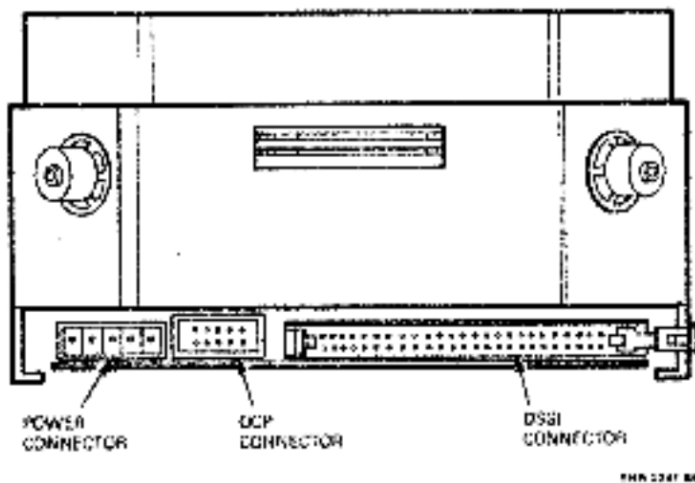

**Figure 4-6: DSSI Bus, Power, and OCP Connectors**

## 4.3 The R215F Enclosure

The R215F expansion enclosure holds up to three RF21 ISEs.

### 4.3.1 Removing the Front Panel

The front panel has a 3-position lock that limits access to system controls. The controls are located behind a plastic window at the upper right of the cover.

Remove the front panel as follows:

1. Insert the key into the lock on the front door. Turn the key to the bottom position (fully clockwise).
2. Slide the window all the way down.
3. Turn the  power switch off (to the right) and unplug the ac power cord from the wall outlet.
4. Halt any bus activity on the host system. Then, remove the DSSI expansion cable.

#### CAUTION

**Make sure you stop any bus activity before removing the DSSI expansion cable to prevent high error rates.**

5. Loosen the two slotted captive screws attaching the DSSI cable to the R215F bis connector (immediately to the left of the OCP) and remove the cable.
6. Pull the release latch outward and use the latch as a hand grip to lift the front door and remove it from the system.

#### CAUTION

**Do not use a screwdriver or other tool to pry open the release latch as this may damage the latch.**

### 4.3.2 Gaining Access to the Top Mass Storage Bays

#### CAUTION

Static electricity can damage integrated circuits. Use an antistatic wrist strap and mat when performing this procedure.

1. Loosen the four captive screws that hold the top media faceplate to the R215F frame and remove the faceplate (Figure 4-7).
2. Remove the two screws from the top of the OCP chassis and lift the OCP out of the enclosure.

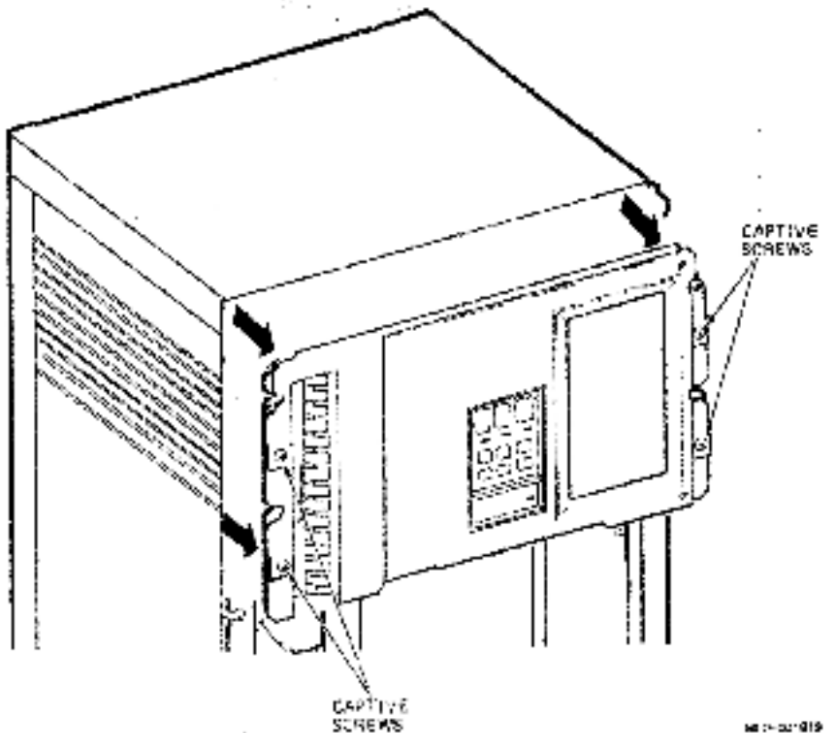

Figure 4-7: Removing the Top Media Faceplate

3. The shipping brackets inside the mass storage area(s) should already have been released during installation of the unit. If they were not released, make sure the four orange plain-slotted screws are loosened to release the shipping brackets. Retighten the screws against the frame after the brackets are released (see [Figure 4-6](#)).

**CAUTION**

Failure to release the shipping brackets prior to use may result in damage to the ISEs..

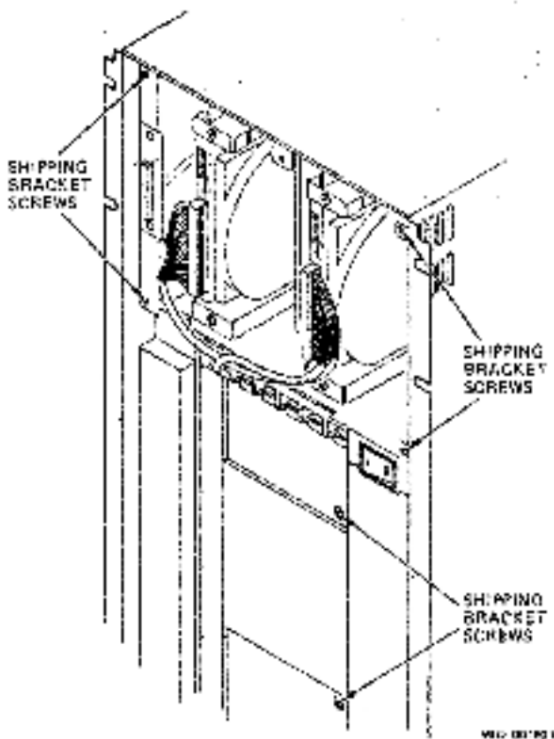

Figure 4-8: R215F Shipping Bracket Screws

### 4.3.3 Gaining Access to the Bottom Storage Bay

#### CAUTION

Static electricity can damage integrated circuits. Use an antistatic wrist strap and mat when performing this procedure.

Loosen the four captive screws that hold the bottom media faceplate to the R215F frame and remove the faceplate (Figure 4-9).

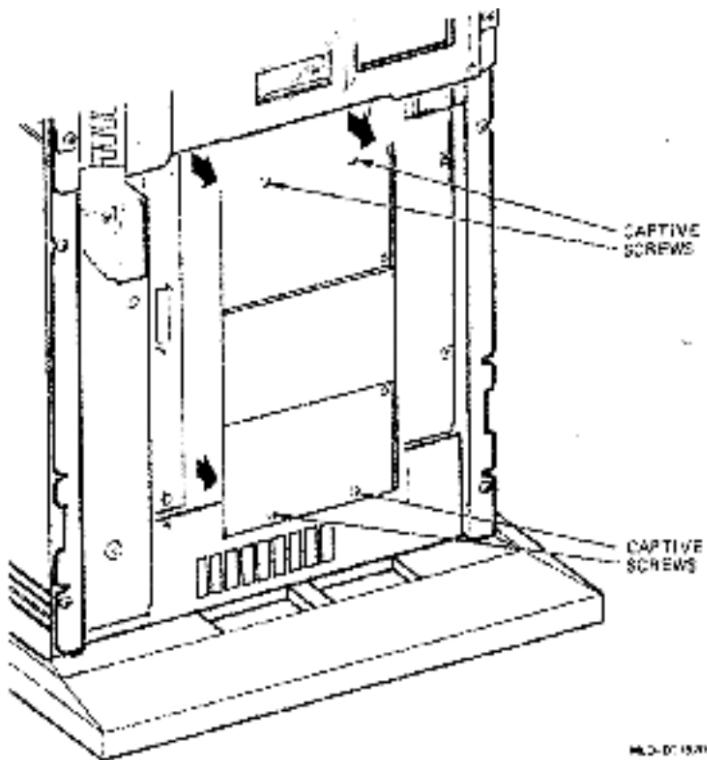

Figure 4-9: Removing the Bottom Media Faceplate

### 4.3.4 Installing the RF71 ISE

#### CAUTION

The RF71 ISE is susceptible to electrostatic damage. Do not handle it unless you are wearing an antistatic wrist strap that is properly grounded to the system cabinet. When you have removed the ISE from its shipping container, place it on an antistatic pad. Use the static-protective Field Service kit (PN 29-26246).

1. Install the upper and lower shock mounts in the mass storage bay using the procedure outlined in [Section 4.1.3](#).

#### CAUTION

Make sure you install the shock mounts shipped with the device. Check the part number against Table 2-1. Installing the wrong shock mounts may result in damage to the ISE.

2. Install the slide rails using the four screws provided. Refer to [Figure 4-5](#) for the location of the screws.

#### CAUTION

Make sure you use the screws provided. Longers screws may damage the ISE.

3. Slide the ISE into the mass storage bay (drive module to the left) and hand tighten the slide rail screws.
4. Connect the power cables to the ISE.
5. Use the 10-conductor cable provided to connect the ISE to the OCP.
6. Connect the DSSI cable to the ISE.
7. Replace the signal distribution assembly and the media faceplate.
8. Install the correct drive select plug on the OCP.



# 5

## Verification

---

This chapter explains how to verify the correct operation of the ISE once it is installed.

### 5.1 Verifying the Correct Operation of an ISE

1. Check all cable connections to the device. Make sure all connectors are seated properly and that there is an appropriate amount of slack in the DSSI cable to allow for vibration of the ISE.
2. Replace all panels on the enclosure.
3. Make sure the DSSI cable is properly connected to both host and expansion box (if applicable).
4. Apply power to the host and to the expansion box (if applicable). The RF71 ISE goes through the power-on self-test (POST) described in [Chapter 6](#). Make sure the green LED in the center of the READY button on the OCP comes on for that ISE. If the red FAULT LED comes on, test the ISE.

## 5-2 Verification

5. Once the READY LED lights, access the local program DRVTST using the following procedure:
  - (a) For a MicroVAX running VMS Version 5.0 or later, type the following command:

```
$ SET HOST/DUP/SERVER-MSCP$DUP/TASK-DRVTST
node-name
```

where:  
node-name = the node name of the device  
Add the qualifier /log=filename.exe to produce a file in your directory of what appears on the screen.  
To learn the node name of the device, type either SHOW DEVICES or SHOW CLUSTER at the \$ prompt.
  - (b) For a MicroVAX using a KA640 module with an embedded DSSI adapter, use the following console command:

```
>>> SET HOST/DUP/DSSI #
```

where:  
# is the DSSI node address of the device you want to access.  
To learn the DSSI node address and node names of the DSSI devices, use the following console command:

```
>>> SHOW DSSI
```

### NOTE

To abort or prematurely terminate the program and return control to the system, press **[CTRL/C]** or **[CTRL/Y]**.

6. Once DRVTST passes, use PARAMS to set device parameters such as node name and allocation class.
7. Fill out a LARS form to complete the installation.

# 6

## Diagnostics

---

This chapter describes the diagnostics available for verifying the operation of the RF71 ISE.

### 6.1 Power-On Self-Test (POST)

All DSSI devices run a power-on self-test (POST) at power-up or when the device is reset to check the integrity of the device hardware. POST has two functions: it performs a sequence of tests to check that the ISE hardware is functioning properly, and it performs start-up procedures to make the ISE operational before becoming available to the host.

POST is executed whenever power is applied. If it is executed successfully, the green READY indicator lights and the red FAULT indicator goes out. If POST fails, the red FAULT indicator remains lit and the READY indicator does not come on, or both indicators remain on.

When POST is initialised, it first activates the spindle spin-up sequence. Spindle spin-up is started first because of the time required for the spindle to come up to speed. Other tests are performed while the spindle is spinning up. When there is more than one ISE on the system, spindle spin-up is staggered to limit the starting current drawn from the power supply for this function. The system controls the staggering through the ACOK signal.

POST is also used to handle the following types of error conditions:

1. *Controller errors* - These are error caused by the hardware associated with the controller function of the drive module. These errors are fatal to the operation of the ISE, since the controller can't establish a logical connection to the host. The result of a failure due to controller error is that the red FAULT LED lights.

## 6-2 Diagnostics

2. *Device errors* - These are errors caused by the hardware associated with the device control function of the drive module. These errors are not fatal, since the ISE can establish a logical connection and report the error to the host. The result of failure due to an ISE error is that both LEDs go out for about one second, then the red FAULT LED lights. In this case, run either DRVTST, DRVEXR, or PARAMS (as explained in the next section) to determine the error code.

## 6.2 Device Resident Diagnostics

The RF71 ISE uses the following local programs to run device diagnostics. These programs use the Diagnostic Utility Protocol (DUP) standard dialog.

- *DIRECT* - provides the directory of available local programs
- *DRVTST* - verifies that the hardware is functioning properly
- *DRVEXR* - exercises the RF30 ISE
- *HISTORY* - displays information retained by the ISE
- *ERASE* - erases all user data from the ISE

A description of each diagnostic local program follows, including a table showing the dialogue of each program. The table also indicates the type of messages contained in the dialogue, although the screen display does not indicate the message type. Message types are abbreviated as

- *Q* - question
- *I* - information
- *T* - termination
- *FE* - fatal error

Local programs can be accessed by using console commands (for MicroVAX 3000-series systems) or the MDM utility, or through VMS using the SET HOST/DUP command. Once the connection is established, operations are performed under the control of the local program. When the program terminates, control is returned to the system.

## 6.2.1 DIRECT

DIRECT provides a directory of all available local programs resident in the RF71 ISE. An example of a DIRECT program display is:

```

Copyright © 1988 Digital Equipment Corporation
DIRECT      V1.0   D   1-NOV-1988   13:39:09
DRVEXR     V1.1   D   1-NOV-1988   13:39:09
DRVST      V1.1   D   1-NOV-1988   13:30:09
ERASE      V1.3   D   1-NOV-1988   13:30:09
HISTORY    V1.0   D   1-NOV-1988   13:30:09
PARAMS     V1.2   D   1-NOV-1988   13:30:09
End of Directory

```

## 6.2.2 DRVTST

DRVTST invokes a comprehensive test of the RF71 ISE hardware. Errors detected by this program are isolated to the FRU level. Dialogue for this test includes:

Message	Message
Type	
I	Copyright Digital Equipment Corporation
Q	Write/read anywhere on the medium? [1=yes/(0=no)]
Q	User data will be corrupted. Proceed? [1=yes/(0=no)]
I	5 minutes to complete.
T	Test passed.
	or
FE	Unit is currently in use. <sup>1</sup>
FE	Operation aborted by user.
FE	xxxx - Unit diagnostics failed. <sup>2</sup>
FE	xxxx - Unit read/write test failed. <sup>2</sup>

<sup>1</sup>This can mean either the device is inoperative, is in use by a host, or is currently running another local program.

<sup>2</sup>For the available error codes, refer to the diagnostic error code table at the end of this chapter.

Answering no to the first question results in a read-only test, and DRVTST writes are limited to a diagnostic area on the disk. Answering yes to the first question results in the second question being asked.

Answering no to the second question has the same effect as answering no to the first question. Answering yes to the second question permits write and read operations anywhere on the medium.

#### NOTE

If the **WRITE PROTECT** switch on the OCP is pressed in (LED on) and the answer to the second question is yes, the device does not allow the test to run. The error message “2006 - Unit read/write test failed” is displayed. In this case, the test has not failed, but has been prevented from running.

DRVST resets the ECC error counters and then calls the timed I/O routine. After the timed I/O routine completes (five minutes), DRVST saves the counters again. It computes the uncorrectable error rate and byte (symbol) error rate. If either rate is too high, the test fails and the appropriate error code is displayed.

### 6.2.3 DRVEXR

The DRVEXR local program exercises the RF71 ISE. The test is data transfer intensive and indicates the overall integrity of the device. The dialogue for DRVEXR includes:

Message	Message
Type	
I	Copyright Digital Equipment Corporation
Q	Write/read anywhere on the medium? [1=yes/(0=no)]
Q	User data will be corrupted. Proceed? [1=yes/(0=no)]
Q	Test time in minutes? [(10)-100]
I	ddd minutes to complete.
I	ddddddd blocks (512 bytes) transferred.
I	ddddddd bytes in error (soft).
I	ddddddd uncorrectable ECC errors (recoverable).
T	Complete
	or
FE	Unit is currently in use. <sup>1</sup>

<sup>1</sup>This can mean either the device is inoperative, is in use by a host, or is currently running another local program.

Message	Message Type
FE	Operation aborted by user.
FE	xxxx - Unit diagnostics failed. <sup>2</sup>
FE	xxxx - Unit read/write test failed. <sup>2</sup>

<sup>2</sup>For the available error codes, refer to the diagnostic error code table at the end of this chapter.

Answering no to the first question results in a read-only test, and DRVEXR writes are limited to a diagnostic area on the disk. Answering yes to the first question results in the second question being asked.

Answering no to the second question has the same effect as answering no to the first question. Answering yes to the second question permits write and read operations anywhere on the medium.

#### NOTE

**If the WRITE PROTECT switch on the OCP is pressed in (LED on) and the answer to the second question is yes, the device does not allow the test to run. The error message "2008 - Unit read/write test failed" is displayed. In this case, the test has not failed, but has been prevented from running.**

DRVEXR saves the error counters and then calls the timed I/O routine. After the timed I/O routine completes, DRVEXR saves the counters again. It then reports the total number of blocks transferred, bytes in error, and uncorrectable errors.

DRVEXR uses the same timed I/O routine as DRVTST with two exceptions. First, DRVTST always uses a fixed time of five minutes, while DRVEXR varies the time of the routine as the user specifies. Second, DRVTST determines whether the device is good or bad. DRVEXR simply reports the data without making any judgements about the condition of the device.

## 6.2.4 HISTORY

This local program displays information about the history of the RF71 ISE. The output generated by HISTORY consists of the following:

Message Type	Field Length <sup>1</sup>	Field Meaning
I	47	Copyright notice
I	4	Product name
I	12	Drive serial number
I	6	Node name
I	1	Allocation class
I	8	Firmware revision level
I	17	Hardware revision level
I	6	Power-on hours
I	5	Power cycles
I <sup>2</sup>	4	Hexadecimal fault code
T		Complete.

<sup>1</sup>Number of ASCII characters

<sup>2</sup>This displays the last 11 fault codes as Information messages. For available error codes, refer to the diagnostic error code table at the end of this chapter.

The following is an example of what appears on the screen when HISTORY is running:

```
Copyright © 1988 Digital Equipment Corporation
RF71
RM01062
SUSAN
0
RFX V101
RF71 PCB-5/ECO-00
617
21
A04F
A04F
A103
A04F
A404
A04F
A404
A04F
A404
A04F
A404
Complete.
```

If no errors have been logged, no hexadecimal fault codes are displayed.

## 6.2.5 ERASE

The ERASE local program is used to overwrite application data on the device disks while leaving the replacement control table (RCT) intact. This local program is used in the event that a mechanics set must be replaced and the customer wants to protect confidential or sensitive data.

ERASE should be used only in the event that the mechanics set must be replaced and only after you have backed up the customer's data.

The dialogue for this program is as follows:

Message	Message
Type	
I	Copyright Digital Equipment Corporation
Q	Write/read anywhere on the medium? [1=yes/(0=no)]
Q	User data will be corrupted. Proceed? [1=yes/(0=no)]
I	6 minutes to complete.
T	Complete
	or
FE	Unit is currently in use.
FE	Operation aborted by user.
FE	xxxx - Unit diagnostics failed. <sup>1</sup>
FE	xxxx - Operation failed. <sup>2</sup>

<sup>1</sup>For the available error codes, refer to the diagnostic error code table at the end of this chapter.

<sup>2</sup>xxxx = one of the following error codes:

- 000D : cannot write the RCT
- 000E : cannot read the RCT
- 000F : cannot find an RBN to revector to
- 0010 : the RAM copy of the bad block table is full

### NOTE

If the **WRITE PROTECT** switch on the OCP is pressed in (LED on) and the answer to the second question is yes, the device does not allow the test to run. The error message "Operation aborted by user" is displayed. In this case, the test has not failed, but has been prevented from running.

If a failure is detected, the message indicating the failure is followed by one or more messages containing error codes.

## 6.3 Diagnostic Error Codes

The diagnostic error codes are displayed when running either DRVTST, DRVEXR, or PARAMS. The following table lists the error codes that may be displayed when running these local programs.

Code	Meaning
3000H - 3009H	Firmware bugcheck, replace the drive module or contact Field Service support.
300AH	Replace the drive module.
300BH	Replace the drive module first, then if necessary the mechanics set.
300CH	Replace the drive module.
300DH	Replace the drive module first, then if necessary the meehanics set.
3300H - 3301H	Firmware bugcheck, replace the drive module or contact Field Service support.
3302H - 3303H	Replace the mechanics set.
3304H	Write/read test failed. Replace the module.
330AH	Firmware bugcheck, replace the drive module or contact Field Service support.
330BH	Replace the drive module.
3400H - 3D04H	Firmware bugcheck, replace the drive module or contact Field Service support.
9001H - 9161H	Replace the drive module.
9162H	Replace the mechanics set.
9200H - 9604H	Replace the drive module.
9314H <sup>1</sup>	Replace the drive module first, then if necessary the OCP.
9606H - 9608H	Replace the drive module first, then if necessary the mechanics set.
9801H - A031H	Replace the drive module.

<sup>1</sup>Front panel is broken. Could be either the module or the OCP or both.

## 6-10 Diagnostics

<b>Code</b>	<b>Meaning</b>
A032H <sup>2</sup>	Replace the drive module first, then if necessary the mechanics set.
A033H - A0039H	Replace the drive module.
A03AH <sup>3</sup>	Replace the drive module or check the system power supply.
A03BH - A04FH	Replace the drive module.
A100H - BF0SH	Firmware bugcheck, replace the drive module or contact Field Service support.

<sup>2</sup>FLT bit of the spindle control status register was asserted for one of the following reasons.

1. Reference clock not present
2. Stuck rotor
3. Bad connection between HDA and module

<sup>3</sup>Cannot spin up, ACLOW is set in WrtFlt. Did not see ACOK signal which is supplied by the host system power supply for staggered spin-up.

# 7

## The PARAMS Utility

---

PARAMS is a local program that allows you to examine and edit internal ISE parameters.

### 7.1 Invoking PARAMS

PARAMS is invoked in the same way as the local programs discussed in the previous chapter. Once invoked, all interaction is through the use of commands and responses. Valid PARAMS commands are listed in [Table 7-1](#).

**Table 7-1: Valid PARAMS Commands**

Command	Definition
HELP	Shows all PARAMS commands and their syntax
SET	Sets a parameter to a value
SHOW	Displays a parameter or a class of parameters
STATUS	Displays module configuration, history, or current counters, depending on the status type chosen
WRITE	Records the device parameters you changed using the SET command
EXIT	Terminates the PARAMS local program

## 7.2 HELP

The HELP command causes a brief list of available PARAMS commands to be displayed. The following is an example of what appears on the screen when you use the HELP command.

```
PARAMS> help
EXIT
HELP
SET {parameter | .} value
SHOW {parameter | . | /class}
    /ALL      /CONST  /DRIVE
    /SERVO    /SCS     /MSCP
    /DUP
STATUS [type]
    CONFIG   LOGS      DATALINK
    PATHS
WRITE

PARAMS>
```

## 7.3 SET

The SET command is used to edit internal ISE parameters. Syntax for the SET command is:

*SET parameter value*

Where *parameter* is the name of the parameter to be set, and *value* is the value you want assigned to the parameter. If abbreviated, the first matching parameter is used without regard to uniqueness.

The WRITE command must be used to record the edits made while using the SET command. SET parameters that are available to the user are listed in [Table 7-2](#).

Examples:

```
PARAMS> SET NODENAME SUSAN
```

This sets the node name of the ISE to SUSAN.

```
PARAMS> SET FORCENAM 1
```

This sets the node name of an RF71 with a DSSI node ID of 0 to RF30A.

**Table 7-2: Summary of SET and SHOW User Parameters**

Parameter	Class	Definition
VOLSERNO	DRIVE	Shows the volume serial number as a quadword.
ALLCLASS	MSCP	Sets or shows the controller allocation class. The allocation class should be set to match that of the host.
UNITNUM	MSCP	Sets or shows the MSCP unit number.
FORCEUNI	MSCP	Determines whether the MSCP unit number or the DSSI node ID will be used. If the FORCEUNI value is 0, the UNITNUM value will be used. If the FORCEUNI value is 1, the DSSI node ID will be used.
FIVEDIME	MSCP	Determines credit connections. If set to 1, MSCP will support five connections with ten credits each. If set to 0, MSCP will support seven connections with seven credits each.
CNT_TMO	MSCP	Shows the MSCP controller timeout value.
ADD_CR	DUP	Determines if DUP will append a RETURN character after each message. True if set to 1, false if set to 0.
ADD_LF	DUP	Determines if DUP will append a LINEFEED character after each message. True if set to 1, false if set to 0.
SYSTEMID	SCS	Sets or shows the controller's 48-bit SCS system ID.
NODENAME	SCS	Sets or shows the SCS node name for the ISE.
FORCENAM	SCS	Determines whether the value set by the NODENAME command will be used or not. If the FORCENAM value is 1, the SCS node name should be forced to the string RF30x or RF71x, where x is a letter from A to H corresponding to the DSSI bus ID (for example, A=0, B=1, and so on) If the FORCENAM value is 0, the value set by NODENAME is used.

## 7.4 SHOW

The SHOW command displays the settings of a parameter or a class of parameters. The full name of the parameter (8 characters or less), the current value, the default value, radix and type, and any flags associated with each parameter are displayed.

Syntax for the SHOW command is:

```
SHOW parameter_or_class
```

Where *parameter\_or\_class* is either a parameter name or a class name. If an abbreviation is used, the first matching parameter is displayed, regardless of uniqueness. The parameter name may also be the special character ".", which will display the last known parameter. If there is no previous parameter, an error is given.

If a class name is used, the class name must be prefixed with a slash (/). SHOW parameters that are available to the user are listed in [tabref7-2](#).

Example:

```
PARAMS> SHOW ADD_CR
Parameter      Current          Default          Type          Radix
-----
ADD_CR                0                0          Boolean        0/1
PARAMS> SET ADD_CR 1
PARAMS> SHOW ADD_CR
Parameter      Current          Default          Type          Radix
-----
ADD_CR                1                0          Boolean        0/1
PARAMS>
```

## 7.5 STATUS

The STATUS command can display module configuration, history, or current counters. The syntax for the STATUS command is:

```
STATUS [type]
```

Where *type* is an option that denotes the type of display desired. If omitted, all available status information is displayed. If present, it may be abbreviated.

Table 7-3 shows the types that are available to the user.

**Table 7-3: Types Available to the STATUS Command**

Type	Definition
CONFIG	Displays the module name, node name, power-on hours, power cycles, and unit failures.
LOGS	Displays the last eleven machine and bugchecks on the module. Included in the display are the processor registers (D0-D7, A0-A7), the time and date of each failure (if available, otherwise the date 17 November 1858 is displayed), and some of the hardware registers.
DATALINK	Displays the data link counters.
PATHS	Displays available path information (open virtual circuits) from the point of view of the controller. The information displayed includes the remote node names, DSSI IDs, software type and version, and counters for the messages/datagrams sent and/or recieved.

Example:

```
PARAMS> STAT CONF
```

```
Configuration:
```

```
Node R39JNA is an RF71 controller
Software RFX V102 built on 1-NOV-1988 13:39:09
Electronics module name is EN0000245
In 41 power-on hours, power has cycled 1 times
System time is 12-NOV-1988 15:00:12
```

```
PARAMS>
```

## 7.6 WRITE

This command is used to record the changes you have made using PARAMS back to nonvolatile memory. The WRITE command is similar in nature to the VMS SYSGEN WRITE command. There are no parameters available. The syntax is simply WRITE at the PARAMS> prompt.

However, when using the WRITE command you must be aware of the system and/or ISE requirements and use the command accordingly or it may not succeed in writing the changes.

The WRITE command may fail for one of the following reasons:

- The user altered a parameter that required the unit, and the unit cannot be acquired (for example, it's not in the available state with respect to the host). Changing the unit number is an example of a parameter that requires the unit.
- The user altered a parameter that required a controller initialization, and the user replied negatively to the request for reboot. Changing the node name or the allocation class are examples of parameters that require controller initialization.
- Initial drive calibrations were in progress on the unit. The use of the WRITE command is inhibited while these calibrations are running.

## 7.7 EXIT

The EXIT command terminates the PARAMS local program. The text "Exiting..." appears on the screen.

The EXIT command is executed by typing either EXIT or CTRLZ.

# Index

---

## A

ACOK, 6-1

## B

BA213, 1-2

BA215, 1-4

## D

DIRECT, 6-3

DRVEXR, 6-4

DRVTST, 6-3

DSSI adapters, 1-1

DSSI node ID number, 3-2

## E

ERASE, 6-8

Error codes, 6-9

EXIT, 7-6

## F

FAULT indicator, 3-3

## H

HELP, 7-2

HISTORY, 6-6

## I

Integrated storage element, 1-1

## O

Operator control panel, 3-3

## P

PARAMS commands, 7-1

Power-on self-test (POST), 6-1

## R

R215F enclosure, 1-5

READY indicator, 6-1

Replacement control table (RCT), 6-8

## S

SET, 7-2

shock mounts, 4-5

SHOW, 7-4

STATUS, 7-5

## W

WRITE, 7-6