

# VAXstation 2000 and MicroVAX 2000 Maintenance Guide

Order Number EK-VSTAA-MG-001

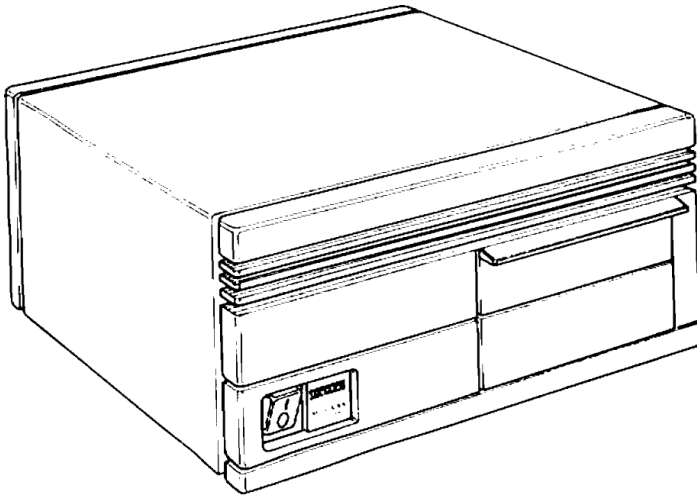

**digital equipment corporation**  
**maynard, massachusetts**

First Edition, January 1987

Copyright ©1987 by Digital Equipment Corporation.  
All Rights Reserved.  
Printed in U.S.A.

The information in this document is subject to change without notice and should not be construed as a commitment by Digital Equipment Corporation.

Digital Equipment Corporation assumes no responsibility for any errors that may appear in this document.

The software, if any, described in this document is furnished under a license and may be used or copied only in accordance with the terms of such license. No responsibility is assumed for the use or reliability of software or equipment that is not supplied by Digital Equipment Corporation or its affiliated companies.

The following are trademarks of Digital Equipment Corporation:

<b>digital</b> ™	EDCS	RSTS
BASEWAY	FMS	RSX
BIBus	MASSBUS	RT
COMPACTape	Micro/RSTS	ThinWire
DEC	MicroPDP-11	UNIBUS
DECconnect	Micro/RSX	VAX
DEC/MAP	MicroVAX II	VAXeluster
DECmate	PDP	VAXstation II
DECnet	P/OS	VAXstation II/GPX
DECUS	Professional	VMS
DECwriter	Q-Bus	VT
DIBOL	Rainbow	

# Contents

---

<b>1</b>	<b>Systems Introduction</b>	<b>1</b>
1.1	The VAXstation 2000 and MicroVAX 2000 Systems . . . . .	1
1.2	Mass Storage Expansion Box for Both Systems . . . . .	5
1.3	Options . . . . .	8
1.3.1	Internal Memory Options . . . . .	8
1.3.2	ThinWire Ethernet Option on MicroVAX 2000 . . . . .	8
1.4	FRU Locations . . . . .	8
<b>2</b>	<b>Testing and Troubleshooting</b>	<b>1</b>
2.1	Introduction . . . . .	1
2.2	Using Console Mode . . . . .	1
2.2.1	Determining the Console Device . . . . .	2
2.2.2	Entering Console Mode . . . . .	2
2.2.3	Exiting Console Mode . . . . .	3
2.2.4	Diagnostic Console Device . . . . .	4
2.2.5	Console Commands . . . . .	4
2.3	Testing . . . . .	5
2.3.1	Power-up Tests . . . . .	5
2.3.2	Self-test . . . . .	9
2.3.3	System Exerciser Diagnostics . . . . .	13
2.4	Troubleshooting Procedures . . . . .	16
2.4.1	MONO – Monochrome Video Troubleshooting Procedures (VAXstation 2000 only) . . . . .	16
2.4.2	CLK – Time-of-Year Clock Troubleshooting Procedures . . . . .	17
2.4.3	NVR – Non-Volatile RAM Troubleshooting Procedures . . . . .	17
2.4.4	DZ – Serial Line Controller Troubleshooting Procedures . . . . .	17
2.4.5	MEM – Memory Troubleshooting Procedures . . . . .	19
2.4.6	MM – Memory Management Unit Troubleshooting Procedures . . . . .	20
2.4.7	FP – Floating Point Unit Troubleshooting Procedures . . . . .	21

2.4.8	IT – Interval Timer Troubleshooting Procedures . . . . .	21
2.4.9	HDC – Disk Drives and Controller Troubleshooting Procedures	21
2.4.10	TPC – Tape Drive Controller Troubleshooting Procedures . . .	29
2.4.11	SYS – Interrupt Controller and ThinWire Ethernet ID ROM Troubleshooting Procedures . . . . .	38
2.4.12	NI – ThinWire Ethernet Network Option Troubleshooting Procedures . . . . .	39
2.4.13	Power Supply Troubleshooting Procedures . . . . .	40
2.4.14	VR260 Monochrome Monitor Troubleshooting Procedures . . .	42
2.4.15	Terminal Communication Troubleshooting Procedures (MicroVAX 2000 only) . . . . .	44
2.5	Utilities . . . . .	46
2.5.1	Configuration Table . . . . .	47
2.5.2	Setting NVR Default Boot Device . . . . .	54
2.5.3	Setting NVR Default Boot Flags . . . . .	54
2.5.4	Setting NVR Default Recovery Action Flags . . . . .	57
2.5.5	Language Inquiry Menu . . . . .	57
2.5.6	Circle Cross-Hatch Alignment Pattern . . . . .	58
2.5.7	Screen of E's Pattern . . . . .	58
2.5.8	White Screen . . . . .	58
2.5.9	Mass Storage Disk Formatter . . . . .	58
2.5.10	Mass Storage Disk Verifier . . . . .	63
2.5.11	Special Diagnostic Key for Field Service System Exerciser . . .	64
2.5.12	ThinWire Network Loop Testing Utility . . . . .	65
<b>3</b>	<b>FRU REMOVAL AND REPLACEMENT PROCEDURES</b>	<b>1</b>
3.1	Introduction . . . . .	1
3.2	Shield Removal . . . . .	4
3.3	System Module Assembly Removal from Shield . . . . .	10
3.4	System Module Removal . . . . .	13
3.5	Memory Module Removal . . . . .	17
3.6	Network Interconnect Module Removal . . . . .	18

3.7	RD53 Hard Disk Drive Removal from System Box . . . . .	19
3.7.1	RD53 Disk Drive Device Electronics Board Removal . . . . .	21
3.8	RX33 and RD32 Drive Removal (Half-Height Drives) from the System Box . . . . .	24
3.8.1	RD32 Disk Drive Device Electronics Board Removal . . . . .	27
3.9	Resistor Load Board Removal from System Box . . . . .	31
3.10	Battery Pack Removal . . . . .	33
3.11	Power Supply Removal from the System Box . . . . .	34
3.12	VAXstation 2000 VR260 Monochrome Monitor . . . . .	35
3.12.1	VR260 Cover . . . . .	36
3.12.2	VR260 Deflection Board Removal . . . . .	39
3.12.3	VR260 Rear Bulkhead Assembly . . . . .	42
3.12.4	VR260 Video Board Removal . . . . .	44
3.12.5	VR260 Transformer Assembly . . . . .	45
3.12.6	VR260 Tube/Yoke/Bezel Assembly Removal . . . . .	47
3.12.7	VR260 LED Assembly . . . . .	50
3.13	Keyboard Removal (VAXstation 2000 only) . . . . .	51
3.14	Mouse and Tablet (VAXstation 2000 only) . . . . .	52
3.15	Terminal Disconnection from MicroVAX 2000 . . . . .	53
3.15.1	DEC423 Converter Removal from MicroVAX 2000 . . . . .	53
3.16	Expansion Adapter Removal . . . . .	54
3.16.1	Expansion Adapter Disk Interface Module Removal . . . . .	56
3.17	VAXstation 2000 and MicroVAX 2000 Expansion Box . . . . .	58
3.17.1	Hard Disk Drive Expansion Box Disconnection from System Box . . . . .	58
3.17.2	Tape Drive Expansion Box Disconnection from System Box . . . . .	72
3.18	Recommended Spares List . . . . .	82
<b>4</b>	<b>Video Monitor Adjustments (VAXstation 2000)</b>	<b>1</b>
4.1	Introduction . . . . .	1
4.2	VR260 Monochrome Monitor . . . . .	1
4.2.1	Preparations . . . . .	2

4.2.2	Horizontal and Vertical Linearity and Focus Adjustments . . .	4
4.2.3	Width, Height, and Centering Adjustments . . . . .	6
4.2.4	Rechecking the Display . . . . .	7
4.2.5	Adjusting Minimum Raster . . . . .	7
4.2.6	Reassembling the VR260 Monitor . . . . .	7

## Figures

1-1	Front View of the VAXstation 2000 and MicroVAX 2000 Systems . . .	2
1-2	Rear View of the VAXstation 2000 System . . . . .	3
1-3	Rear View of the MicroVAX 2000 System . . . . .	4
1-4	Front View of the Hard Disk Expansion Box . . . . .	5
1-5	Front View of the Tape Drive Expansion Box . . . . .	6
1-6	System Box with Expansion Adapter . . . . .	7
1-7	FRU Locations in the System Box . . . . .	8
1-8	FRU Locations in the Expansion Boxes . . . . .	9
2-1	Example of Power-up Tests Screen Display . . . . .	5
2-2	Power-up Symbols Defined . . . . .	6
2-3	Example of Power-up Tests Screen Display with Errors. . . . .	7
2-4	Example of the Configuration Table . . . . .	8
2-5	Example of Running Self-test on the Disk Controller . . . . .	9
2-6	Example of Running a Series of Self-tests . . . . .	10
2-7	Example of a Self-test Error on the Disk Controller . . . . .	12
2-8	System Exerciser Display Example . . . . .	15
2-9	Example of MEM System Exerciser Error Code . . . . .	20
2-10	HDC Power-up and Self-test Error Code . . . . .	22
2-11	Example of System Exerciser Display for the Disk Controller . . . . .	24
2-12	RD32 Drive Select Jumper Setting for DUA0 . . . . .	28
2-13	RD53 Drive Select Jumper Setting for DUA0 and DUA1 . . . . .	28
2-14	RX33 Drive Select Jumper Setting for DUA2 . . . . .	29
2-15	TPC Power-up and Self-test Error Code . . . . .	30

2-16	Example of System Exerciser Display for the Tape Controller . . . . .	32
2-17	TZK50 Controller Board Jumper Locations . . . . .	37
2-18	Flowchart for Troubleshooting the Power Supply . . . . .	40
2-19	Power Connectors Pin Voltages . . . . .	41
2-20	Flowchart for Troubleshooting Terminal Communications . . . . .	44
2-21	Flowchart for Troubleshooting Terminal Communications on the DEC423 Converter . . . . .	45
2-22	Example of the Configuration Table . . . . .	47
2-23	Example of the DZ Line in the Configuration Table . . . . .	48
2-24	Example of MEM Error Display in the Configuration Table . . . . .	49
2-25	Example of the Second HDC Line in the Configuration Table . . . . .	50
2-26	Example of the Second TPC Line in the Configuration Table . . . . .	51
2-27	Example of the System Module's ROM Code Revision Levels . . . . .	52
2-28	Example of Tape Port Bus Information . . . . .	53
2-29	Example of the TZK50 and TK50 ROM Revision Levels . . . . .	54
2-30	Example of Changing the Default Boot Device . . . . .	54
2-31	Example of Changing the Default Boot Flag . . . . .	55
2-32	Determining the NVR Code for Three Boot Flags . . . . .	55
2-33	Example of Changing the NVR Recovery Action Flags . . . . .	57
2-34	Example of Formatting a Hard Disk Drive . . . . .	59
2-35	Example of Formatting an RX33 Floppy Diskette . . . . .	60
2-36	Example of Formatting an Unknown Hard Disk Drive . . . . .	61
2-37	Example of Running the Disk Verifier on DUA1 . . . . .	63
2-38	Example of Creating the Special Key on a Floppy Diskette . . . . .	65
2-39	Example of Creating the Special Key on a COMPACTape Cartridge . . . . .	65
2-40	Example of ThinWire Ethernet Loop Testing Using TEST 90 . . . . .	67
3-1	FRU Locations . . . . .	3
3-2	Expansion Adapter Cover Screw Locations . . . . .	4
3-3	System Box Cover Screw Locations . . . . .	5
3-4	System Box Cover Removal . . . . .	6
3-5	Shield Screw Locations . . . . .	7

3-6	Removing the Shield from the Main Chassis . . . . .	8
3-7	Disconnecting the Cables from the Shield . . . . .	9
3-8	System Module Assembly Screw Locations on the Shield . . . . .	10
3-9	Network Interconnect Cables . . . . .	11
3-10	Removing System Module Assembly from Shield . . . . .	12
3-11	Battery Cable Location . . . . .	13
3-12	Memory Module Removal . . . . .	14
3-13	Network ID ROM Location on System Module . . . . .	15
3-14	VAXstation 2000 and MicroVAX 2000 System Jumper . . . . .	16
3-15	Memory Module Removal . . . . .	17
3-16	Network Interconnect Module Removal . . . . .	18
3-17	Hard Disk Screw Locations . . . . .	19
3-18	Disconnecting the Hard Disk Drive from System Box . . . . .	20
3-19	Drive Mounting Bracket Screw Locations . . . . .	21
3-20	RD53 Device Electronics Board Removal . . . . .	22
3-21	RD53 Device Electronics Board Jumper and Switch Locations . . . . .	23
3-22	Half-Height Drive(s) Screw Locations . . . . .	24
3-23	Disconnecting the RX33 and RD32 Half-Height Drives . . . . .	25
3-24	Half-Height Drives Mounting Brackets Removal . . . . .	26
3-25	RD32 Device Electronics Board Screw Locations . . . . .	27
3-26	Disconnecting J4 from RD32 Device Electronics Board . . . . .	28
3-27	Disconnecting J5 and J6 from RD32 Device Electronics Board . . . . .	29
3-28	RD32 Device Electronics Board Jumper Location . . . . .	30
3-29	Drive Mounting Bracket Screw Locations . . . . .	32
3-30	Battery Cable Location . . . . .	33
3-31	Power Supply Screw Locations in the System Box . . . . .	34
3-32	VR260 FRU Locations . . . . .	35
3-33	VR260 Controls and Video Cable Locations . . . . .	36
3-34	VR260 Cover Screw Locations . . . . .	37
3-35	VR260 Rear Bezel Location . . . . .	38
3-36	VR260 Side Door Screw Locations . . . . .	39

3-37 High-Voltage Discharge Tool . . . . .	40
3-38 VR260 Deflection Board . . . . .	41
3-39 VR260 Rear Bulkhead Screw Locations . . . . .	42
3-40 VR260 Rear Bulkhead . . . . .	43
3-41 VR260 Video Board . . . . .	45
3-42 VR260 Transformer Assembly . . . . .	46
3-43 VR260 Tube/Yoke/Bezel Assembly Screw Locations . . . . .	47
3-44 VR260 Tube/Yoke/Bezel Assembly's LED Cable . . . . .	48
3-45 VR260 Cable Connections . . . . .	49
3-46 VR260 LED/Bezel Assembly . . . . .	50
3-47 Disconnecting the Keyboard (VAXstation 2000) . . . . .	51
3-48 Disconnecting the Mouse or Tablet (VAXstation 2000) . . . . .	52
3-49 DEC423 Converter's Mounting Screw Locations . . . . .	53
3-50 Expansion Adapter Screws . . . . .	54
3-51 Expansion Cables Locations . . . . .	55
3-52 Expansion Adapter Cover Screws Location . . . . .	56
3-53 Expansion Adapter Disk Interface Module Cables and Screw Locations	57
3-54 Hard Disk Expansion Box Cable . . . . .	59
3-55 Hard Disk Expansion Box Cover Screw Locations . . . . .	60
3-56 Resistor Load Board Power Cable . . . . .	61
3-57 Hard Disk Expansion Box Shield Screw Locations . . . . .	62
3-58 Hard Disk Expansion Box Drive Mounting Screws . . . . .	63
3-59 Hard Disk Expansion Box Drive Cables Locations . . . . .	64
3-60 Hard Disk Expansion Box Drive Mounting Bracket Screws Location	65
3-61 Hard Disk Expansion Box Cover Screw Locations . . . . .	66
3-62 Hard Disk Expansion Box Resistor Load Board Power Cable . . . . .	67
3-63 Hard Disk Expansion Box Shield Screw Locations . . . . .	68
3-64 Hard Disk Expansion Box Power Supply Mounting Screw Locations	69
3-65 Hard Disk Expansion Box Cover Screw Location . . . . .	70
3-66 Hard Disk Expansion Box Resistor Load Board Power Cable . . . . .	71
3-67 Tape Drive Expansion Box Data Cable . . . . .	72

3-68	Tape Drive Expansion Box Cover Screw Locations . . . . .	73
3-69	TZK50 controller Board Cable Locations . . . . .	74
3-70	TZK50 Controller Board Jumper and Resistor Pack Locations . . . . .	75
3-71	Tape Drive Expansion Box Shield Screw Locations . . . . .	76
3-72	Tape Drive Expansion Box Drive Mounting Screw . . . . .	77
3-73	TK50 Tape Drive Cable Locations . . . . .	78
3-74	Tape Drive Mounting Brackets Screw Locations . . . . .	79
3-75	Tape Drive Expansion Box Power Supply Mounting Screw Locations . . . . .	80
3-76	Tape Drive Expansion Box Resistor Load Board Power Cable Locations . . . . .	81
4-1	Brightness and Contrast Controls . . . . .	3
4-2	VR260 Infernal Adjustment Locations . . . . .	4
4-3	Circle Cross-Hatch Display . . . . .	5
4-4	Width and Height Measurements . . . . .	6

**Tables**

2-1	Prompts . . . . .	2
2-2	Keyboard LEDs Defined . . . . .	7
2-3	Self-test Commands . . . . .	10
2-4	System Exerciser Diagnostic Commands . . . . .	14
2-5	MEM System Exerciser Error Codes . . . . .	20
2-6	Power-up and Self-test Error Codes for each Dlsk Drive . . . . .	23
2-7	HDC Disk Controller System Exerciser Error Codes . . . . .	25
2-8	HDC Dlsk Drive System Exerciser Error Codes . . . . .	26
2-9	TPC Tape Controller System Exerciser Error Codes . . . . .	33
2-10	Tape Drive Expansion Box System Exerciser Error Codes . . . . .	34
2-11	VR260 Troubleshooting Table . . . . .	42
2-12	Utilities . . . . .	46
2-13	Determining the Location of the Failing Memory Bank . . . . .	49
2-14	Boot Flags Used by VMB for Booting All Operatlng System Software . . . . .	55
2-15	Specific Boot Flags Used by VMS . . . . .	56

2-16 Default Recovery Flags . . . . .	57
2-17 Disk Formatter Messages . . . . .	62
2-18 Error Codes for the Disk Formatter . . . . .	62
2-19 Disk Verifier Messages . . . . .	64
2-20 Error Codes for the Disk Verifier . . . . .	64
2-21 ThinWire Ethernet Loopback Test Report Definitions . . . . .	68
3-1 FRU Section Listings . . . . .	1
4-1 Base Video Alignment Test Commands . . . . .	1

## ABOUT THIS BOOK

This book describes how to troubleshoot, adjust, and repair the VAXstation 2000 and the MicroVAX 2000 Workstation to the field replaceable unit (FRU) level in the field. It covers all FRU options presently available for these two Systems.

- [Chapter 1](#) contains a System overview that outlines the components of the VAXstation 2000 and MicroVAX 2000 Systems.
- [Chapter 2](#) contains testing and troubleshooting procedures to help isolate the problem to an FRU.
- [Chapter 3](#) contains FRU removal and replacement procedures.
- [Chapter 4](#) contains video monitor adjustment procedures for the VAX station 2000 monitor.
- [Chapter 5](#) contains installation instructions for each option available on both the VAXstation 2000 and the MicroVAX 2000.
- [Appendix A](#) contains a list of the test commands.
- [Appendix B](#) contains a complete listing and definitions of the console commands.
- [Appendix C](#) contains a complete listing and definitions of the console messages.
- [Appendix D](#) contains a complete listing and definitions of the VMB boot error Status codes.

The detailed [index](#) and [glossary](#) also help you find Information.

### Notes, Cautions, and Warnings

Notes, cautions, and warnings appear throughout this book.

- Notes contain general, supplemental Information about a topic.
- Cautions contain information to prevent damage to equipment.
- Warnings contain information to prevent personal injury.

## REFERENCE MANUALS

Manual	Order Number
VAXstation 2000 Hardware Installation Guide	<a href="#">EK-VAXAA-IN</a>
VAXstation 2000 Owner's Manual	<a href="#">EK-VAXAA-OM</a>
VAXstation 2000/MicroVAX 2000 Technical Manual	<a href="#">EK-VTTAA-TM</a>
MicroVAX 2000 Hardware Installation Guide	<a href="#">EK-MVXAA-IN</a>
MicroVAX 2000 Owner's Manual	<a href="#">EK-MVXAA-OM</a>
VR290 Service Guide	<a href="#">EK-VR290-SM</a>
VAXstation 2000, MicroVAX 2000, VAXmate Network Guide	<a href="#">EK-NETAA-UG</a>
RD53 Technical Description Manual	<a href="#">EK-RD53A-TD</a>
RX33 Technical Description Manual	<a href="#">EK-RX33T-TM</a>
TZK50/SCSI Controller Technical Manual	<a href="#">EK-TZK50-TM</a>

## TOOLS AND MATERIALS

You will need the following tools and materials to service the VAXstation 2000 and MicroVAX 2000 Systems.

- Field Service Tool Kits
  - 50 Hz Tool Kit p/n 29-23270-00
  - 60 Hz Tool Kit p/n 29-23268-00
- VR260 Video Monitor Tools
  - Metric Measuring Tape p/n 29-25342-00
  - High-Voltage Anode Discharge Tool p/n 29-24717-00
- ThinWire Ethernet Tools
  - Face Plate Installation Kit p/n H8242



## **1.1 The VAXstation 2000 and MicroVAX 2000 Systems**

The VAXstation 2000 and MicroVAX 2000 systems are mechanically identical. Both come in the same style box, both use the same drives, and both use the same mass storage expansion boxes. Also, both use the same diagnostic tools for troubleshooting and repair. Once familiar with troubleshooting one system, you'll be able to troubleshoot the other if necessary. One major difference is the VAXstation 2000 is a single-user system and the MicroVAX 2000 is a multiuser system. Another difference is the VAXstation 2000 uses a video monitor while the MicroVAX 2000 uses video terminals.

Both the VAXstation 2000 and the MicroVAX 2000 have three main pieces of hardware. They are the System box, the hard disk expansion box, and the tape drive expansion box. The System box can have a half-height RX33 floppy disk drive, a half-height RD32 hard disk drive, or both the RX33 and the RD32. A full-height RD53 hard disk drive can be substituted for the half-height drives in the System box. The hard disk expansion box comes with a full-height RD53 hard disk drive. The tape drive expansion box comes with a TK50 tape drive.

Figure 1-1 shows the front of the VAXstation 2000 and MicroVAX 2000 systems. There are three ways to differentiate between the two systems: the medallion next to the power switch on the front, the DEC423 converter on the back, or the system jumper position on the system module inside the box.

**Figure 1-1: Front View of the VAXstation 2000 and MicroVAX 2000 Systems**

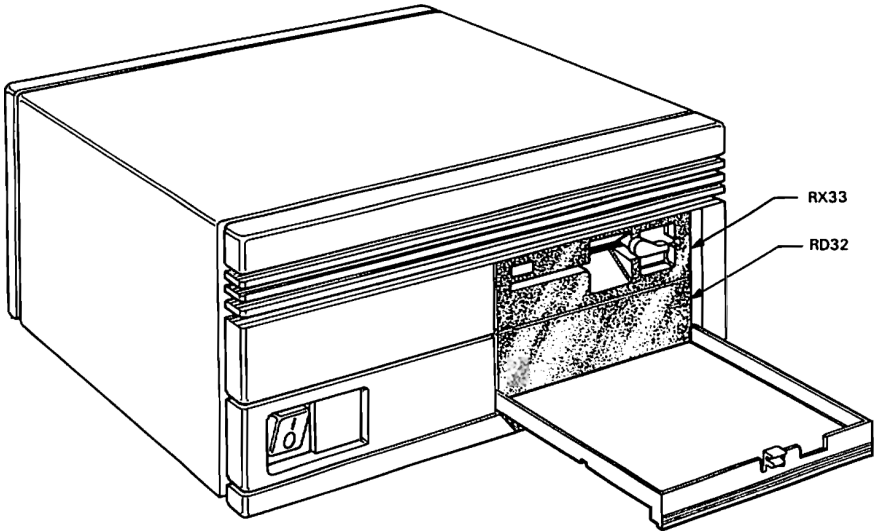

MR-1286-1405  
MA 0063-B7

Figure 1-2 shows the rear view of the VAXstation 2000 and labels each connector. A modem or a terminal can be connected to the 25-pin communication port. A VR260 monochrome monitor can be connected to the 15-pin video port. A printer can be connected to the 9-pin printer port. The ThinWire Ethernet port Supports IEEE 802.3 (Standard Ethernet) network communications connections over the ThinWire Ethernet cable.

**Figure 1-2: Rear View of the VAXstation 2000 System**

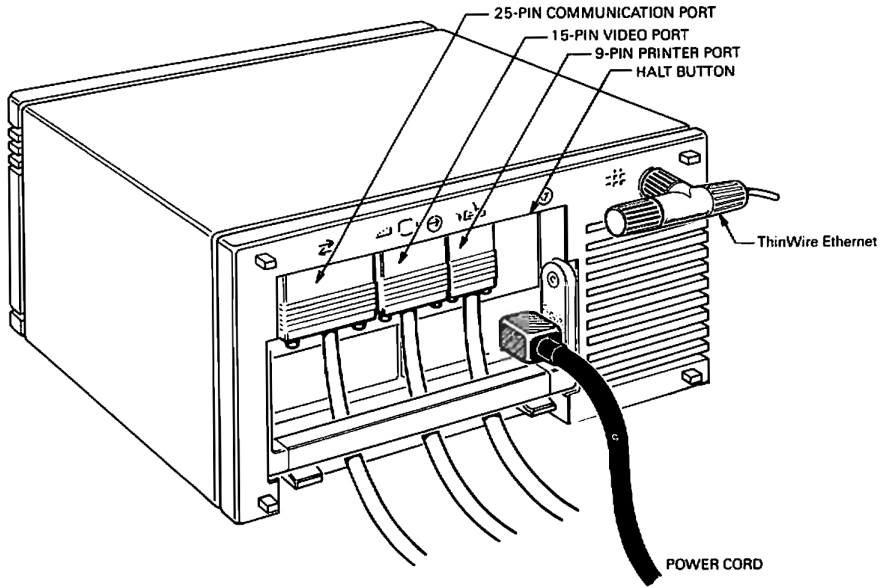

MR-1086-1246  
MA-0132-B7

Figure 1-3 shows the rear view of the MicroVAX 2000 and labels each connector. Like the VAXstation 2000, the MicroVAX 2000 supports a modem or a terminal on the 25-pin communication port. The MicroVAX 2000 supports the DECconnect strategy which uses the modified modular jack (MMJ) 6-conductor telephone type cable (DEC423 asynchronous protocol) for connection to the terminals. The DEC423 Converter changes the 15-pin video port and the 9-pin printer port (RS232 protocol) to three MMJ communication ports. Port 1 on the DEC423 Converter is reserved for the console terminal. Ports 2 and 3 can have either a terminal or a printer attached to them. The operating system Software configures each port for either a terminal or a printer. The ThinWire Ethernet port supports IEEE 802.3 (Standard Ethernet) network communications connections over the ThinWire Ethernet cable.

**Figure 1-3: Rear View of the MicroVAX 2000 System**

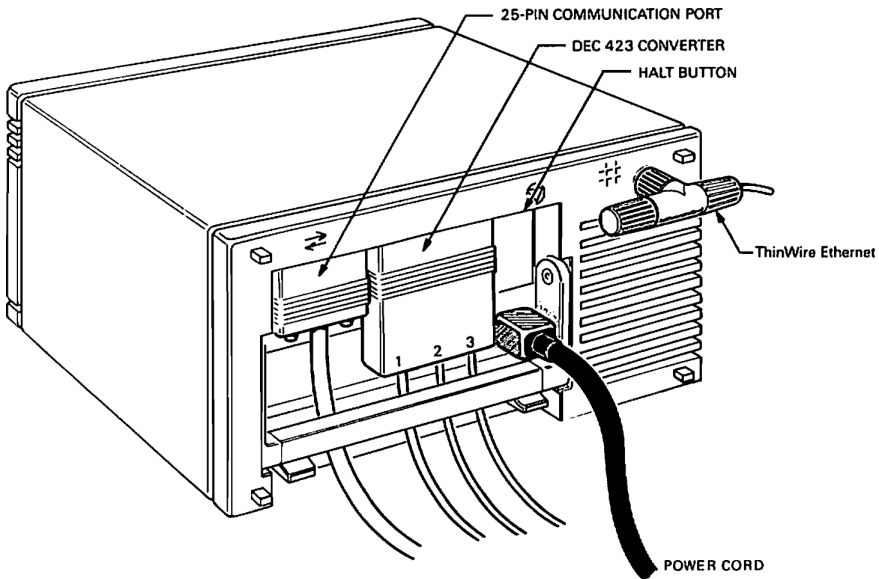

MR-1086-1245  
MA-0134-B7

## 1.2 Mass Storage Expansion Box for Both Systems

Additional mass storage devices are contained in expansion boxes that look very similar to the system box. [Figure 1-4](#) and [1-5](#) show the front view of the expansion boxes.

The hard disk expansion box contains an RD53 or RD54 hard disk drive. The tape drive expansion box contains a TK50 tape drive and a controller board. Each expansion box contains a power supply, a resistor load board (to regulate the power supply), and the drive.

**Figure 1-4: Front View of the Hard Disk Expansion Box**

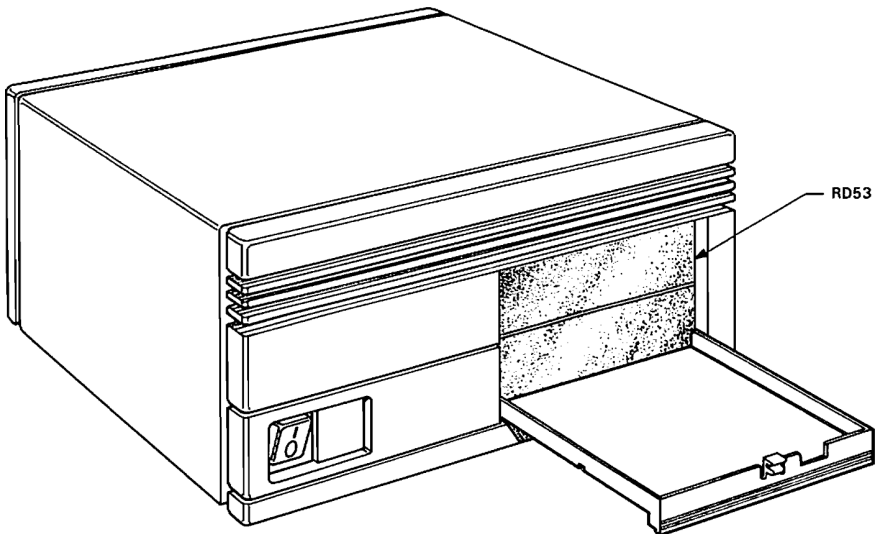

MR-1286-1406  
ISA-0065-87

**Figure 1-5: Front View of the Tape Drive Expansion Box**

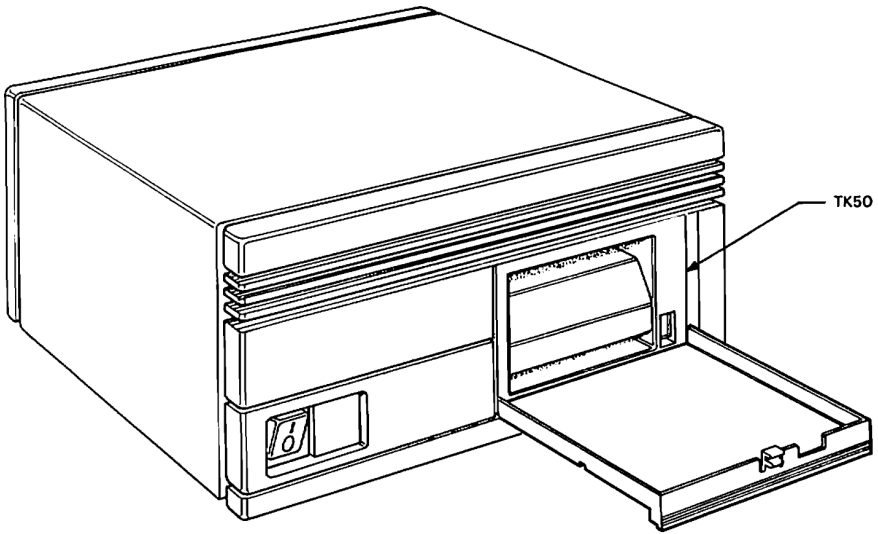

MR-1286-1410  
MA-0064-B7

Both expansion boxes connect to the system box through an expansion adapter that attaches to the bottom of the system box. The expansion adapter has three connectors on the back labeled ports A, B, and C. Port A connects the tape expansion box to the system. Port B connects the hard disk expansion box to the system. Port C is reserved for future options. Figure 1-6 shows the back of a MicroVAX 2000 system box with an expansion adapter.

**Figure 1-6: System Box with Expansion Adapter**

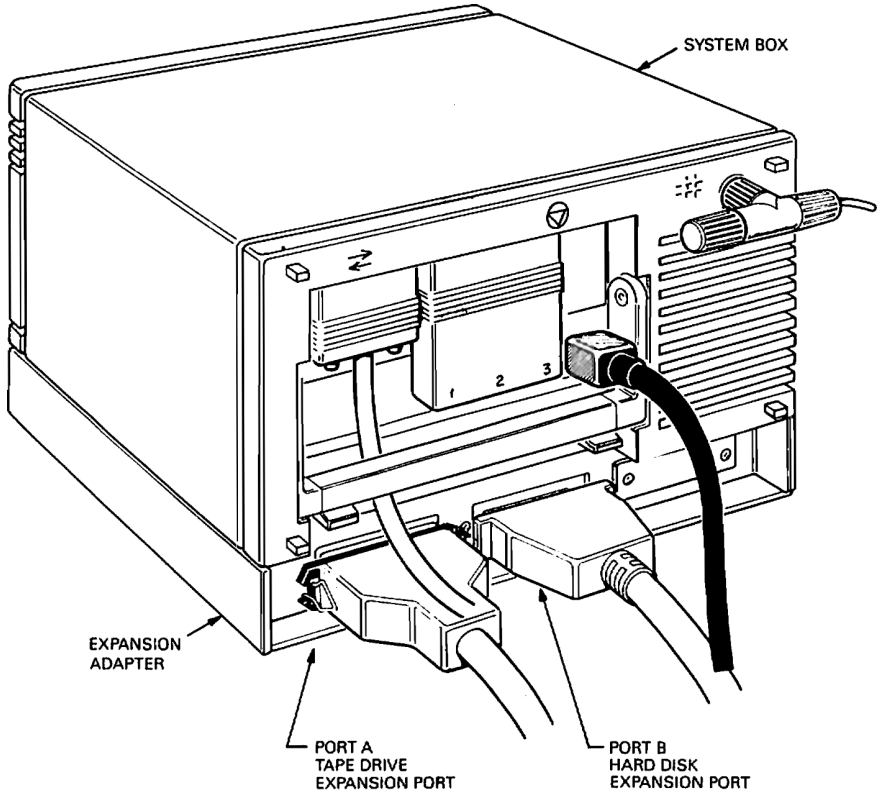

MR-1286-1409  
MA-0135-B7

# 1.3 Options

## 1.3.1 Internal Memory Options

Two additional memory modules are available for both systems. One is a 2-megabyte memory module and the other is a 4-megabyte memory module. The memory module is located in the system box and is connected directly to the system module.

## 1.3.2 ThinWire Ethernet Option on MicroVAX 2000

ThinWire Ethernet is an option on the MicroVAX 2000. It comes standard on the VAXstation 2000. It adds the capability of connecting the system to the DECnet through the ThinWire Ethernet network. The option consists of a network interconnect module that is located in the system box and is connected to the system module through two 40-conductor cables.

# 1.4 FRU Locations

Figure 1-7 shows the locations of the FRUs in the system box. Figure 1-8 shows the locations of the FRUs in the expansion boxes.

**Figure 1-7: FRU Locations in the System Box**

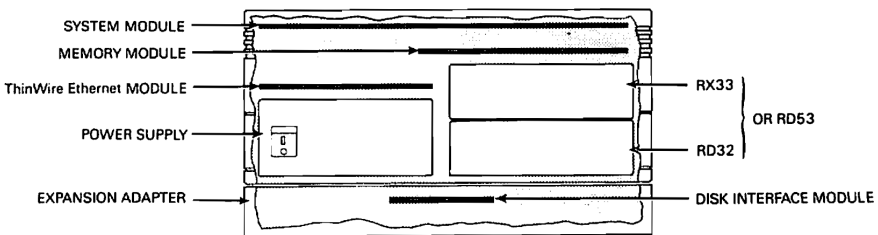

VAXstation 2000 AND MicroVAX 2000 SYSTEM BOX

MA 0150 07

**Figure 1-8: FRU Locations in the Expansion Boxes**

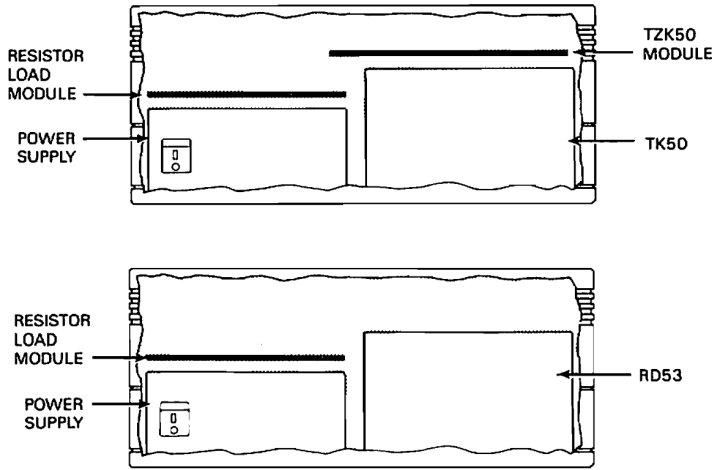

VAXstation 2000 AND MicroVAX 2000 EXPANSION BOXES

MR-1186-1275  
MA-0133-B7



## Chapter 2

# Testing and Troubleshooting

---

## 2.1 Introduction

This chapter describes how to test and troubleshoot the VAXstation 2000 and the MicroVAX 2000 systems. Differences between the VAXstation 2000 and the MicroVAX 2000 are specifically identified in the text.

This chapter contains the following sections.

- How to use console mode: determining the console device, entering console mode, exiting console mode, utilizing the diagnostic console device, and where to find a list of the console commands.
- How to run the diagnostic tests and interpret the error codes for each test: power-up tests, self-test, and system exerciser.
- How to troubleshoot all devices in the system.
- How to use the utilities.

## 2.2 Using Console Mode

The VAXstation 2000 and the MicroVAX 2000 systems have two modes of operation: program mode and console mode. Normal operation of the VAXstation 2000 and the MicroVAX 2000 is in program mode, that is, with the operating system controlling the system. Console mode allows the user to control the system from the console terminal using the console commands described in [Appendix B](#). Console mode is contained in ROM on the system module.

Testing is done while in console mode. The system returns the >>> prompt when it is in console mode. [Table 2-1](#) lists the prompts and the mode of operation each prompt represents.

**Table 2-1: Prompts**

Prompt	Mode of operation
>>>	Console mode. Console commands are listed in <a href="#">Appendix B</a> .
\$	Program mode (VMS operating system)
%	Program mode (Ultrix operating system)

## 2.2.1 Determining the Console Device

The console device for a VAXstation 2000 system is the keyboard (LK201) and monitor (VR260) connected to the video port. The keyboard inputs commands at 4800 baud and the monitor displays output from the video circuits.

The console device for a MicroVAX 2000 system is the terminal (VT220 or similar terminal) connected to connector 1 on the DEC423 converter. The terminal operates at 9600 baud.

## 2.2.2 Entering Console Mode

Console mode is entered any time the CPU halts. The CPU can be halted automatically or manually. A halt means that CPU control has passed control from the operating system to the console mode program in ROM. If the system halts the CPU, then the console mode program checks the nonvolatile RAM (NVR) for user-defined instructions on how to handle the halt. If you manually halt the CPU, the system enters console mode program immediately without checking the NVR for instructions.

You can manually halt the CPU and enter console mode by one of the following methods.

- HALT button – Press the halt button. It is located next to the printer port on the back of the system box. The >>> prompt is displayed when ready for console commands.
- BREAK key – Press the BREAK key on the diagnostic console device that is connected to the printer port with the BCC08 cable. The >>> prompt is displayed when ready for console commands.

The system automatically halts the CPU for the following reasons.

- After power-up testing – If the default recovery action is halt, the system automatically halts the CPU and enters console mode after power-up tests are complete. See [Paragraph 2.5.4](#) for information on setting the default recovery actions.
- For a boot failure – If the system fails to boot properly, the system automatically halts the CPU and enters console mode. See [Paragraph 2.5.2](#)

for information on setting the default boot device.

- On a system error – If the CPU detects a severe corruption of its operating environment, it halts and reads the default recovery action in the NVR. The default recovery action can be restart, boot, or halt. When it is restart and the restart fails, then the system automatically tries to boot the operating system software. If the boot fails, the CPU halts and enters console mode. When the default recovery action is boot and the boot fails, the CPU halts and enters console mode. When the default recovery action is halt, the CPU unconditionally halts and enters console mode.

One other way to halt the CPU is when the operating system software executes a halt instruction. The CPU then reads the default recovery action in the NVR and acts on it as described above.

## 2.2.3 Exiting Console Mode

Console mode is exited by typing one of the following console commands.

- **BOOT** – This command initializes the CPU and boots the operating system software from the device specified. If no device is specified, the system searches each on-line device until the operating system software is found. The boot command starts the system similar to when power is turned on except that the power-up tests are not run. If the system attempts to boot over the net (ESA0) and no software is available on another node, the system keeps looking for the software indefinitely. If a boot message for the operating system software does not appear shortly after the Ethernet boot message (ESA0) is displayed, then you must press the halt button to abort the Ethernet boot. If you still need to boot over the Ethernet, make sure the node with the operating system software is operating normally and the software is loaded. Run the Ethernet loopback utility (TEST 90) to check the networking capability of the system if the Ethernet boot continues to fail. When a boot is invoked using this boot command, you can specify several boot command flags by bit encoding the flags in a flag word specified with the /R5: qualifier. These command flags are listed in Paragraph 2.5.3.
- **CONTINUE** – This command instructs the CPU to continue the operating system software at the address contained in the program counter (PC). This command starts up the operating software where it was halted provided no console test commands were run. Running a test command alters the PC and memory so that the operating system software cannot be started properly by entering the continue command. If a test command was entered, use the boot command to start the operating system software. The continue command is similar to the start command. The start command can specify the address to start the operating software and the continue command has the operating software continue where it left off.

- **START** – This command starts the operating system software at a specified address. If no address is given, the contents of the PC are used. However, running a test command alters the PC and memory so that the operating system software cannot be started properly by entering the start command. If a test command was entered, use the boot command to start the operating system software.

## 2.2.4 Diagnostic Console Device

There is a diagnostic console device available on the VAXstation 2000. The MicroVAX 2000 can use this device if the DEC423 Converter is removed.

The diagnostic console device can be utilized by connecting a terminal (such as the VT100 or VT220) to the printer port with the special BCC08 cable. The terminal operates at 9600 baud. Field service technicians can use this terminal as a diagnostic tool to isolate a problem in the normal console device.

To use this diagnostic console device you must turn off power, connect the BCC08 cable to the printer port and terminal, and then turn power back on. The diagnostic console device now controls the system. The normal console monitor displays video test patterns on the VAXstation 2000 when the video circuits are tested. The normal console keyboard does not operate.

## 2.2.5 Console Commands

Console commands are listed in [Appendix B](#).

## 2.3 Testing

Testing procedures on the VAXstation 2000 and the MicroVAX 2000 systems are almost identical. The differences between the systems are explained where applicable. All diagnostic tests are ROM-based and testine is done while in console mode. Tests are executed in either of two ways:

- Automatically – When power is turned on the power-up tests begin.
- Manually – By entering one of the console test commands on the console terminal. See [Appendix A](#) for a complete listing of the test commands.

### 2.3.1 Power-up Tests

Power-up tests run each time the system power is turned on. Power-up testing consists of a sequence of tests executed for each device installed in the system. The test number of each device is listed on the power-up screen display as the device is tested. [Figure 2-1](#) shows an example of the powerup screen display. The first line indicates the CPU name (KA410-A) and the ROM version (V1.0). The test numbers are listed next in descending order from the first test, F, to the final test, 1. TEST F will have an underscore after it on the MicroVAX 2000 to indicate that TEST F was not run. Note in [Figure 2-1](#) that tests 4, 3, 2, and 1 have an underscore (\_) immediately after them. This underscore indicates that there is no option device installed for that test; thus, no tests are done. TEST F has an underscore after it on the MicroVAX 2000 systems because the monochrome video circuits are not used by the MicroVAX 2000. No other test numbers can have underscores after them. An asterisk (\*) after TESTS 4 through 1 indicate that an option is installed, but its ROM is destroyed and the Option device must be replaced. Only TESTS 1 through 4 can have an asterisk after them. [Figure 2-2](#) lists the symbols that can appear in between the tests and what they indicate.

#### Figure 2-1: Example of Power-up Tests Screen Display

```
KA410-A V1.0  
F...E...D...C...B...A...9...8...7...6...5...4...3...2...1...
```

[Figure 2-2](#) lists the definitions of the symbols that appear between the test numbers in the power-up test countdown.

## Figure 2-2: Power-up Symbols Defined

```
... Device tested successfully or has a soft error
?... Device has a hard error
_.. Device not installed or not tested
*.. Device installed but its ROM is destroyed
```

If any hard errors (errors that indicate the device must be replaced for proper operation) are found during power-up testing, a question mark is placed after the failing test number during the countdown sequence. An error summary of all errors detected is listed after the power-up sequence is complete. Two question marks in the error summary indicate a hard error. Error codes that indicate the status or soft errors do not put a question mark after the failing test number in the sequence, but do list the error code in the error summary. [Figure 2-3](#) shows the power-up screen display with a hard error found in TEST F and a soft error found in TEST E. The error summary for each failed device is displayed before the boot sequence is started. However, the screen usually scrolls so fast when the system starts to boot that you may not be able to see what the error summary contained (if there was an error summary). To see what errors the power-up tests found, press the halt button and enter TEST 50 on the console terminal. TEST 50 is the command for bringing up the configuration table. The configuration table is created during power-up testing. This configuration table contains all of the error codes listed in the power-up error summary as well as error codes for all devices installed in the system. The error codes in the configuration table are updated every time self-test is run. See Paragraph 2.5.1 for an explanation of how to use the configuration table.

Each error summary consists of one or two question marks, a test number, the ID number of the failed device, and an eight-digit error code. For example, in [Figure 2-3](#), the first line of the error summary shows a hard error for TEST F, a device ID number of 00B0, and an error code of 0001.F002. The second line shows a soft error for TEST E, a device ID of 0040, and an error code of 0000.0005. [Section 2.3.1.1](#) describes the error codes.

**Figure 2-3: Example of Power-up Tests Screen Display with Errors.**

```
KA410-A V1.0  
F?..E...0...C...B...A...9...8...7...6...5...4...3...2...1...  
?? F 00B0 0001.F002  
? E 0040 0000.0006
```

If there is a fatal error in the NVR during power-up testing, the system stops testing the other devices and displays ?14 TOY ERR on the screen. When this happens, the only way to determine the cause of the problem is by viewing the LEDs on the keyboard. One of the LEDs will be lit to indicate the failing module. [Table 2-2](#) lists the LEDs and which module has failed.

**Table 2-2: Keyboard LEDs Defined**

Keyboard LED	Failing module
Hold Screen	System module
Lock	Not used
Compose	ThinWire Ethernet option module
Wait	Not used

Once power-up testing is complete and no fatal or hard errors are found, the system boots the operating system software. Both the VAXstation 2000 and the MicroVAX 2000 boot the operating system software the same. The only difference between the two is that the VAXstation 2000 clears the console screen before it boots and the MicroVAX 2000 does not. If a default boot device is loaded in the NVR, the system boots off of that device. If no default device is loaded in the NVR, the system searches every on-line storage drive for the operating software. DUA2 is searched first if a floppy diskette is loaded. Otherwise, it is not searched at all. The hard disks are searched next, DUA0 then DUA1. MUA0, the tape drive, is checked after the hard disk drives if it is installed and a cartridge is loaded. Finally, the system searches the Ethernet network for the software and ESA0 is listed on the screen. The system continues to search the Ethernet network until the operating system software is found.

### 2.3.1.1 Power-up Test Error Codes

The power-up test error codes indicate status and/or error information. Any errors found by power-up tests are listed in the error summary after the power-up test countdown sequence. This summary, if any, gives you a brief summary of the errors. [Table 2-3](#) lists the test numbers and the devices that are tested during that particular test. To look at the complete list of devices and the status of that device, you must display the configuration table. The configuration table lists every device in the system and also lists the results of the self-test and power-up tests and is updated each time self-test is run. The error codes for each device in the configuration table are explained in the troubleshooting section for that individual device. Remember that the configuration table contains the results of the self-test and power-up tests and not the results of the system exerciser. [Figure 2-4](#) shows an example of the configuration table and for an explanation of the configuration table, see [Paragraph 2.5.1](#).

**Figure 2-4: Example of the Configuration Table**

```
>>> TEST 50

KA410-A V1.0
ID 08-00-2B-02-CF-A4

?? MONO          0001.F002
?  CLK          0000.0005
  NVR          0000.0001
  DZ           0000.0001
            00000001 00000001 00000001 00000001 00000001 000012A0
MEM          0002.0001
            00200000
MM           0000.0001
FP           0000.0001
IT           0000.0001
HDC          1710.0001
            000146B8 00000000 00000320
TPC          0202.0001
            FFFFFFF03 01000001 FFFFFFF06 FFFFFFF05 FFFFFFF05 FFFFFFF05 ...
SYS          0000.0001
NI           0000.0001 V1.0

>>>
```

The most common good error code is 0000.0001. There are, however, some devices that use the first four digits in the error code to indicate the status of the device and the last four digits to indicate the error found on the device. The memory (MEM) error code, for instance, contains 0002.0001 which indicates two megabytes of memory is available (0002.) and no error found (.0001). On devices like these, the last four digits always indicate .0001 as a good (non-error) indication.

Some error codes indicate no error at all and give a status of the device such as the clock (CLK) which shows that the date and time has not been set. This is not an error, just a status of the clock circuits.

Any error code other than 0000.0001 on the MONO, MM, FP, IT, or SYS devices indicates a hard error and that device must be replaced for proper operation of the system. The other devices such as CLK, NVR, DZ, MEM, HDC, TPC, and NI may have a status or a soft error message in the error codes and may still operate normally.

See the troubleshooting procedures section (Paragraph 2.4) for each device to determine whether or not the error code indicates a fault or a status for the device.

## 2.3.2 Self-test

Self-test allows you to test every device again individually, a few at a time, or all of them sequentially just like power-up tests. To individually test a device, enter TEST # where # is the test number of the device you want tested. [Table 2-3](#) lists the test numbers and the devices tested by those numbers. [Figure 2-5](#) shows an example of running self-test successfully on the disk controller.

### Figure 2-5: Example of Running Self-test on the Disk Controller

```
>>> TEST 7
      7...
>>>
```

To test a group of devices, enter TEST followed by the test number of the first device to be tested and then the test number of the last device to be tested. [Figure 2-6](#) shows an example of testing a group of devices. In [Figure 2-6](#), all tests between C and 4 are tested successfully. Note that you cannot pick and choose which devices to test between C and 4, all tests between C and 4 are tested when entered as a group.

**Figure 2-6: Example of Running a Series of Self-tests**

```
>>> TEST C 4
    C...B...A...9...8...7...6...5...4...
>>>
```

To test all devices, enter TEST F 1. The MicroVAX 2000 skips over the MONO video test (TEST F) since it does not use the video circuits.

**Table 2-3: Self-test Commands**

TestNumber	Device Tested
1	Option module (Network Interconnect module) (NI)
2	Option module (not available)
3	Option module (not available)
4	Option module (not available)
5	Interrupt Controller and ThinWire Ethernet ID ROM (SYS)
6	Tape Controller. (TPC)
7	Disk controller. (HDC)
8	Interval timer. (IT)
9	Floating point unit. (FP)
A	Memory management unit. (MM)
B	Memory. (MEM)
C	DZ Controller. (DZ)
D	Non-volatile RAM. (NVR)
E	Time-of-year dock. (CLK)
F	Base video (MONO) (VAXstation 2000 only)

### 2.3.2.1 Self-test with Loopback Connectors

Customer mode self-test does not test the drivers or the lines of the serial line controller (DZ) since loopbacks are not used. Run self-test in field service mode to test the DZ drivers by installing the loopback connectors on the back of the system. Follow one of the procedures below.

To test the DZ on VAXstation 2000, install a loopback (p/n 29-24795) on the 25-pin communication port and a loopback (p/n 29-24794) on the 9-pin printer port. Run TEST C. You cannot use loopback connectors if you are using the diagnostic console device with the BCC08 cable on the printer port since there is no loopback connector for the video port.

To test the DZ on MicroVAX 2000, install a loopback (p/n 29-24795) on the 25-pin communication port and install an MMJ loopback on both ports 2 and 3. Run TEST C.

**NOTE:** *The ThinWire Ethernet port on the back of the system box must be terminated properly when running diagnostics on the network option (TEST 1) otherwise an error code of 0000.7001 or greater is listed in the configuration table.*

### 2.3.2.2 Self-test Error Codes

Figure 2-7 shows how an error is displayed if found during self-test. This example shows an error on the disk controller during self-test. The 84 FAIL indicates an error was found on the device tested. You must display the configuration table (TEST 50) after self-test is complete to see the error code, if there is an error during self-test, since the error codes do not appear on the screen. The configuration table lists every device in the system, lists the results of the self-test and power-up tests, and is updated each time self-test is run. The error codes for each device in the configuration table are explained in the troubleshooting section for that individual device. Remember that the configuration table contains the results of the self-test and power-up tests and not the results of the system exerciser. See Paragraph 2 5 1 for an explanation of the configuration table.

## Figure 2-7: Example of a Self-test Error on the Disk Controller

```
>>> TEST 7
      7?..
      84 FAIL
>>>
```

(You must display the configuration table to see the error code)

## 2.3.3 System Exerciser Diagnostics

The system exerciser simulates a worst-case situation test for each device and checks how the device operates under these conditions. It does not use the configuration table to list its results of the tests. The system exerciser has a separate display that appears on the screen as the exerciser is running. Any errors found are displayed in the exerciser display. When examining the exerciser display, a single question mark in the far left column indicates a soft error, a double question mark indicates a hard error, and the absence of question marks indicate success. [Figure 2-8](#) shows an example of the exerciser display.

The system exerciser exercises most of the devices. However, some devices such as the memory management unit (MM) and the interval timer (IT) are tested through the testing of other devices and are not displayed. Of the devices the exerciser does exercise, it runs each one sequentially until all have been run once, then it runs them all at the same time (worst-case). This type of testing usually finds any intermittent failures.

The system exerciser has two modes: customer mode and field service mode. Customer mode system exerciser (TEST 0) does not use loopback connectors and does not fully test all of the devices. Field service mode system exerciser requires loopback connectors installed and removable media from the maintenance kit inserted and loaded. You must initialize the floppy diskette in the maintenance kit with a special diagnostic key so the exerciser can perform write tests on the RX33. Refer to Paragraph 2.5.11 for more Information on creating the special diagnostic keys. Once the floppy has been initialized, load it into the RX33 (if a full read/write test of the RX33 is necessary) before you run the system exerciser in field service mode. You must also initialize the COMPACTape cartridge in the maintenance kit with a special diagnostic key so the exerciser can perform read/write tests on the TK50. Refer to Paragraph 2.5.11 for more information on creating the special diagnostic keys. Once the COMPACTape cartridge has been initialized, load it into the TK50 (if a full read/write test of the TK50 is necessary) before you run the system exerciser in field service mode. If the RX33 or the TK50 are not loaded with the special-key media, the system exerciser does not do destructive writes to them and tests them the same as it does during the customer mode system exerciser. This special-key on the media prevents the exerciser from accidentally destroying data on the customers floppy diskette or COMPACTape cartridge. The field service mode system exerciser is available in a run once (TEST 101) and a run forever (TEST 102) configuration.

### 2.3.3.1 System Exerciser Diagnostic Commands

Table 2-4 lists the system exerciser diagnostic commands.

**Table 2-4: System Exerciser Diagnostic Commands**

Test Commands	Description of Commands
0	Runs customer mode system exerciser. It exercises each device once sequentially, then exercises them simultaneously, and stops when the slowest device finishes its second pass. No loopback connectors and no removable media required.
101	Runs field service system exerciser. It exercises each device once sequentially, then exercises them simultaneously, and stops when the slowest device finishes its second pass. Do not stop the exerciser before it finishes exercising every device twice (second pass). Loopbacks and removable media required.
102	Runs field Service system exerciser. It exercises each device once sequentially and then exexcises them simultaneously until you enter a <b>[CTRL/C]</b> . Note that the exerciser takes up to thirty seconds to stop after you enter <b>[CTRL/C]</b> . Do not stop the exerciser until every device is exercised twice (second pass). Also, do not press the halt button to stop the exerciser. Loopbacks and removable media required.

When the exerciser is started, PRA0 is displayed and the monitor connected to the video port on the VAXstation 2000 blinks white and black several times while the monochrome circuits are being tested. The results of the MONO tests are then displayed on the console screen. MicroVAX 2000 does not use the MONO circuits and, therefore, does not test them. The DZ test results are the first to be displayed on the console screen. The rest of the devices are then exercised one at a Urne and the results are listed on the display. The console displays the results of each device until the last device is finished testing. When the last device is done, the exerciser starts running all devices together at the same time. When this happens, the monitor connected to the video port starts blinking again until the slowest device finishes testing. On the MicroVAX 2000, the console terminal holds the first pass display until the slowest device is done testing then displays a new exerciser display. The console screen (VAXstation 2000 and MicroVAX 2000) displays the results of each device tested. This display stays on the screen for about 10 seconds, then the exerciser starts running all devices together again if TEST 102 was entered. If TEST 0 or TEST 101 was entered, the exerciser stops after the slowest device is done testing. The halt message is displayed when the exerciser is stopped.

To run the field service mode system exerciser on VAXstation 2000, install a loopback (p/n 29-24795) on the 25-pin communication port and a loopback (p/n 29-24794) on the 9-pin printer port. Insert and load the floppy diskette and TK50 COMPACTape cartridge from the maintenance kit if the system has these devices installed. Run the exerciser by entering TEST 101 or TEST 102. If you are using the diagnostic console device, you will get errors on the DZ line since there is no

loopback for the video port.

To run the field service mode system exerciser on MicroVAX 2000, install a loopback (p/n 29-24795) on the 25-pin communication port and install an MMJ loopback on both ports 2 and 3. Insert and load the scratch floppy diskette and scratch TK50 COMPACTape cartridge from the maintenance kit if the system has these devices installed. Run the exerciser by entering TEST 101 or TEST 102. If the scratch floppy or TK50 cartridge is not installed, the system tests those devices the same as in customer mode.

### 2.3.3.2 System Exerciser Error Codes

Figure 2-8 shows an example of the system exerciser display while running the system exerciser in field service mode. Customer mode gives the same display, but with a CU in place of the FS on the top of the display.

**Figure 2-8: System Exerciser Display Example**

```
KA410-A V1.0          01      FS

  F 00B0    MONO    0000.0001    2      0 00:00:55.01
  C 0080    DZ      0000.0001    5      0 00:01:28.03
  B 0010    MEM     0175.0001    2      0 00:02:03.07
  7 0090    HDC     2000.0001    4      0 00:02:08.58
  ?                0700.7091                0 00:02:08.58
  ??                1002.0051                0 00:01:03.45
                2500.0001
  6 00A0    TPC     1000.0001    9      0 00:02:44.04
                1300.0001
  ?? 1 00CO    NI    0000.7004    3      0 00:04:46.32

>>>
```

(The error codes are defined in the troubleshooting procedures for each individual device)

The first line indicates the CPU name (KA410-A), the ROM version (V1.0), the ROM Status (01 – the ROM is corrupted if this is anything other than 01), and the mode of the system exerciser (CU for customer and FS for field service mode). The next several lines list information on the devices that are exercised by the system exerciser.

The first column of the display lists the test number (F,C,B,7,6,1). TESTS 4 through 1 are option modules and these options may not be installed. They are listed in the display only if they are installed. The second column lists the device identifier (00B0, 0080, 0010,...). Next is the mnemonic for each device (MONO, DZ, MEM,...) followed by the error code (0000.0000) for that device (the HDC and TPC devices have additional error codes for each drive). After the error

code is the number of times the device was tested followed by the time of the last pass the exerciser made on that device. The time is in the format of days hours:minutes:seconds.hundredths of seconds. Question marks identify hard (??) and soft (?) errors. See the troubleshooting procedures ([Paragraph 2.4](#)) for the device that has an error detected with it.

## 2.4 Troubleshooting Procedures

Each section below contains troubleshooting information for the device indicated. Find the section below with the mnemonic (such as MONO or TPC) that you want to troubleshoot. Once the section is located, read through the procedures to familiarize yourself with the testing of the device.

### 2.4.1 MONO – Monochrome Video Troubleshooting Procedures (VAXstation 2000 only)

You can troubleshoot the monochrome circuitry on the system module in either customer mode or field service mode. Both modes test the monochrome circuits the same. This procedure does not troubleshoot the video monitor, just the video circuits on the system module.

#### 2.4.1.1 Self-test

To run self-test on MONO, enter TEST F. The monitor connected to the video port blinks white and black several times. This is normal. The results of the self-test are displayed when self-test is complete. Any error code other than 0000.0001 indicates a fault in the monochrome video circuits. You must replace the system module to fix this problem.

#### 2.4.1.2 System Exerciser

To run the system exerciser, enter TEST 0 for customer mode or TEST 101 for field service mode. The monitor connected to the video port blinks white and black several times while the monochrome circuits are being tested. The results of the MONO tests are displayed on the console screen after they are tested for the first time, then displayed again after each concurrent testing. Any error code other than 0000.0001 indicates a fault in monochrome video circuits. You must replace the system module to fix this problem. This device is not exercised on the MicroVAX 2000 system since MicroVAX 2000 does not use video monitors.

## **2.4.2 CLK – Time-of-Year Clock Troubleshooting Procedures**

You can troubleshoot the CLK circuitry in either customer mode or field service mode. Both modes test the CLK circuits the same.

### **2.4.2.1 Self-test**

To run self-test, enter TEST E. Any error code other than 0000.0001 indicates a fault in the CLK circuits. An error code of 0000.0005 indicates that the system time is not set. Refer to the operating system software documentation to set the time. If any other error code appears in the CLK error display, you must replace the system module.

The system exerciser does not display the Status of the CLK circuits. The CLK circuits are not directly tested but are tested through the testing of other circuits.

## **2.4.3 NVR – Non-Volatile RAM Troubleshooting Procedures**

You can troubleshoot the NVR circuitry in either customer mode or field service mode. Both modes test the NVR circuits the same.

### **2.4.3.1 Self-test**

To run self-test, enter TEST D. Any error code other than 0000.0001 indicates a fault in the NVR. An error code of 0000.0005 indicates that the battery charge is below the normal voltage level. If the battery is low, allow the system to charge the battery for five minutes and then run TEST D again. If the error code is still 0000.0005, replace the battery. A charging time of 20-25 hours is needed to fully charge the battery. Leaving the system powered up charges the battery. If any other error code appears in the CLK error display, you must replace the system module.

The system exerciser does not display the status of the NVR circuits. The NVR circuits are not directly tested but are tested through the testing of other circuits.

## **2.4.4 DZ – Serial Line Controller Troubleshooting Procedures**

You can troubleshoot the DZ in either customer mode or field service mode. The difference between the two modes is that field service mode tests the serial line drivers on the system module and customer mode does not.

#### **2.4.4.1 Self-test**

To run customer mode self-test on either the VAXstation 2000 or the MicroVAX 2000, enter TEST C. Loopback connectors must not be installed when in customer mode. Loopback connectors must, however, be installed to run field service mode diagnostics. Any error code other than 0000.0001 indicates a fault in the DZ controller. You must replace the system module to fix the problem. If you are using the diagnostic console device, any error code other than 0000.4001 indicates a fault in the DZ controller.

##### **VAXstation 2000**

To run self-test in field service mode on VAXstation 2000, install a loopback (p/n 29-24795) on the 25-pin communication port and a loopback (p/n 29-24794) on the 9-pin printer port. Enter TEST C. If the error code is not 0000.0001, check to see if the loopbacks are still connected. Reconnect them, if necessary, and test again. Replace the system module if the error still exists. Loopbacks cannot be used to test the DZ controller when the console device is the diagnostic console with the BCC08 cable since there is no loopback for the video port.

##### **MicroVAX 2000**

To run self-test in field service mode on MicroVAX 2000, install a loop back (p/n 29-24795) on the 25-pin communication port and install an MMJ loopback on both ports 2 and 3. Enter TEST C. If the error code is not 0000.0001, check to see if the loopbacks are still connected. Reconnect them, if necessary, and test again. Replace the system module if the error still exists.

#### **2.4.4.2 System Exerciser**

To run the customer mode system exerciser on either the VAXstation 2000 or the MicroVAX 2000, enter TEST 0. The results are displayed on the video screen as the tests are completed.

##### **VAXstation 2000**

To run the field service mode system exerciser on VAXstation 2000, install a loopback (p/n 29-24795) on the 25-pin communication port and a loopback (p/n 29-24794) on the 9-pin printer port. Enter TEST 101. If you are using the diagnostic console device, you will get errors on the DZ line since there is no loopback for the video port. Any error code other than 0X00.0001, where X is the serial line being used for the console device, indicates a fault in the DZ controller. You must replace the system module to fix the problem. If the console device is connected to the video port on VAXstation 2000, then you will see a 0 (zero) in the X position. If the console device is the diagnostic console device with the BCC08 cable on the printer port, then you will see a 3 in the X position. If the error code is not 0X00.0001, check to see if the loopbacks are still connected. Reconnect them, if necessary, and test again. Replace the system module if the error still exists.

## MicroVAX 2000

To run the field service mode system exerciser on MicroVAX 2000, install a loopback (p/n 29-24795) on the 25-pin communication port and install an MMJ loopback on both ports 2 and 3. Enter TEST 101 or TEST 102. Any error code other than 0X00.0001, where X is the serial line being used for the console device, indicates a fault in the DZ controller. You must replace the system module to fix the problem. With the console device connected to port 1 on the MicroVAX 2000, you will see a 0 (zero) in the X position. If the error code is not 0X00.0001, check to see if the loopbacks are still connected. Reconnect them, if necessary, and test again. Replace the system module if the error still exists. If the error still exists after replacing the system module, replace the DEC423 converter on the back of the system box.

## 2.4.5 MEM – Memory Troubleshooting Procedures

You can troubleshoot memory in either customer mode or field service mode. Both modes test the MEM circuits the same. These procedures are for both VAXstation 2000 and MicroVAX 2000.

### 2.4.5.1 Self-test

To run self-test, enter TEST B. Any error code other than 000X.0001, where X is the size of memory (megabytes) in the system, indicates a fault in the memory circuits. The problem could either be with the system module or the memory Option module. To determine which module is at fault go to [Paragraph 2.5.1.2](#).

### 2.4.5.2 System Exerciser

To run the system exerciser, enter TEST 0 for customer mode or TEST 101 for field service mode. [Figure 2-9](#) shows what the MEM system exerciser error code indicates. The status portion of the code indicates the number of pages tested during the last test pass (1 page = 512 bytes) if there were no errors found.

**Figure 2-9: Example of MEM System Exerciser Error Code**

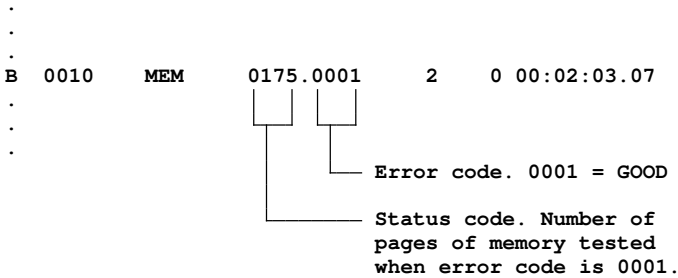

An error code of .0001 indicates no errors. If errors were detected during the last test pass, the error portion of the code contains the error code. [Table 2-5](#) lists the MEM system exerciser errors and shows which module is causing the error.

**Table 2-5: MEM System Exerciser Error Codes**

Error Codes	Definition
0001.001F	Compare error on the system module
0002.001F	Compare error on the Option module
0001.002F	Parity error on the system module
0002.002F	Parity error on the Option module

## 2.4.6 MM – Memory Management Unit Troubleshooting Procedures

You can troubleshoot the memory management (MM) circuitry in either customer mode or field service mode. Both modes test the MM circuits the same.

### 2.4.6.1 Self-test

To run self-test, enter TEST A. Any error code other than 0000.0001 indicates a fault in the memory management circuits. You must replace the system module to fix the problem.

The system exerciser does not display the status of the MM circuits. The MM circuits are not directly tested but are tested through the testing of other circuits.

## **2.4.7 FP – Floating Point Unit Troubleshooting Procedures**

You can troubleshoot the floating point (FP) circuitry in either customer mode or field service mode. Both modes test the FP circuits the same.

### **2.4.7.1 Self-test**

To run self-test, enter TEST 9. Any error code other than 0000.0001 indicates a fault in the floating point circuits. You must replace the system module to fix the problem.

The system exerciser does not display the status of the FP circuits. The FP circuits are not directly tested but are tested through the testing of other circuits.

## **2.4.8 IT – Interval Timer Troubleshooting Procedures**

You can troubleshoot the interval timer (IT) circuitry in either customer mode or field service mode. Both modes test the IT circuits the same.

### **2.4.8.1 Self-test**

To run self-test, enter TEST 8. Any error code other than 0000.0001 indicates a fault in the timing circuits. You must replace the system module to fix the problem.

The system exerciser does not exercise the IT circuits.

## **2.4.9 HDC – Disk Drives and Controller Troubleshooting Procedures**

You can troubleshoot the disk controller and drives using self-test and the system exerciser. These diagnostics test the disk controller on the system module and also test the drives connected to the controller. There is a maximum number of three drives that can be supported in either a VAXstation 2000 or a MicroVAX 2000. The three drives are labelled DUA0, DUA1, and DUA2. DUA0 will always be the hard disk drive (RD) located in the system box. DUA0 can be a full-height or a half-height drive. DUA1 will always be the hard disk drive (RD) located in the expansion box. DUA1 communicates to the system module through port B on the expansion adapter; thus allowing you to isolate DUA1 during testing, if necessary, without opening the system box. DUA2 will always be the half-height floppy disk drive (RX33) and will only be located in the system box. If DUA0 is a full-height drive, then a floppy disk drive cannot be installed because of lack of space in the system box. The disk controller labels any drive off-line that is not installed. It also labels DUA2 off-line if a floppy diskette is not properly loaded.

### 2.4.9.1 Self-test

To run self-test on the HDC, enter TEST 7. Self-test gives a quick status of the disk controller on the system module and the drives. You can run self-test in either customer mode or field service mode since both modes test these devices the same. The error code for the disk controller (HDC in the configuration table) contains the test results of the disk controller and the status of the three drives. [Figure 2-10](#) shows how the error code is broken into five segments: status of DUA2, DUA1, DUA0, tape controller, and the error code if a hard error is found. The power-up error code is the same as the self-test error code.

**Figure 2-10: HDC Power-up and Self-test Error Code**

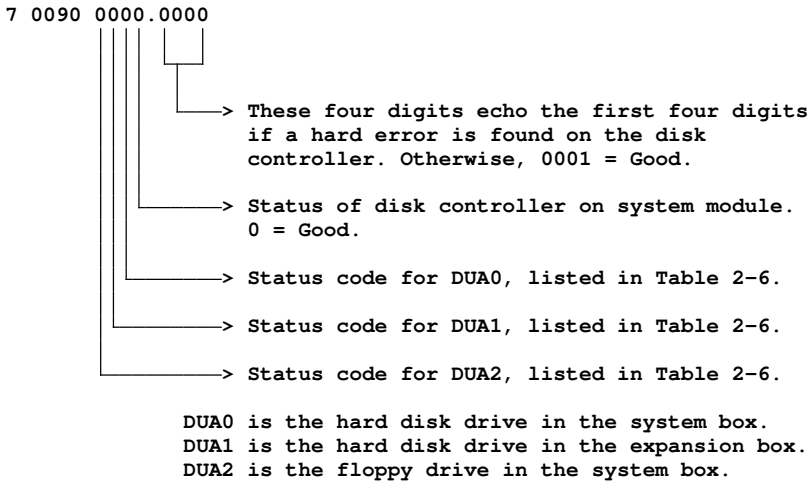

Each drive has the same set of error codes. These codes are listed in [Table 2-6](#). All odd-numbered error codes are soft errors or a status. All even-numbered error codes (including A and F) are hard errors. The last four digits of the error code repeat the first four digits if a hard error is found on the disk controller. Otherwise, the last four digits contain 0001 to indicate no errors or soft errors.

**Table 2-6: Power-up and Self-test Error Codes for each Disk Drive**

Error Codes	Description of error codes for each disk drive
1	Good – No error for this drive.
2	Drive select error. Disk controller or the drive failed. Replace the system module first. Replace the drive if the problem is not fixed after replacing the system module.
3	Read during read test error. The disk or diskette may not be formatted. Run the disk verifier to check out the disk. Copy the disk data onto another disk or to another system over the net if you have to reformat the drive.
4	Read after write error. Drive failed. Replace the drive first. Replace the system module if the problem is not fixed after replacing the drive.
5	Invalid UIB (DUA0 and DUA1 only). Disk needs formatting or the disk is not a Digital disk. Run the disk verifier to check out the disk. Copy the disk data onto another disk or to another system over the net if you have to reformat the drive.
6	Drive failed to restore. Drive failed. Replace the drive first. Replace the system module if the problem is not fixed after replacing the drive.
7	Off-line — No drive installed, no floppy diskette loaded in DUA2, or DUA1 (in expansion box) is not turned on.
8	Drive not done error. Drive failed. Replace the drive first. Replace the system module if the problem is not fixed after replacing the drive.
9	Invalid Status from controller. Disk controller or diskette failed. If DUA0 or DUA1, replace the system module first then replace the disk drive if the problem is not fixed after replacing the system module. If DUA2, replace the floppy diskette first or save the data on it and reformat it. If DUA2 and the floppy diskette is not the problem, replace the system module and then replace the floppy disk drive if replacing the system module did not fix the problem.
A	Drive select timeout error. Drive failed. Replace the drive first. Replace the system module if the problem is not fixed after replacing the drive.
F	Untested – Drive was not tested because of a hard error found on the disk controller. For example, FFF8.FFF8 indicates an error on the disk controller and no drives were tested. Replace the system module.

If any error (except 7 and F) appears for any drive, check the drive for power and check the cables for a good connection. If the error still exists, the problem is either in the drive, in the cables, in the system module, or in the disk interface module located in the expansion adapter. If, for example, you replace one of the disks to fix an error code and the error still exists, replace the system module. If the system module does not fix the problem replace the disk interface module.

### 2.4.9.2 System Exerciser

Start the system exerciser by entering TEST 0 for customer mode or install the 25-pin loopback on the communications port and enter TEST 101 for field service mode. The customer mode system exerciser does not exercise the disks as thoroughly as the field service exerciser. The field service system exerciser performs a complete read/write test on all drives and also performs a data transfer test between the disk controller and one of the drives.

The results of the system exerciser are displayed on the screen after the first test pass of each device tested and again after all devices have been run concurrently. [Figure 2-11](#) shows the system exerciser display for the disk controller (HDC). There is one line for the controller Status and one line for each drive connected to the controller. A drive that is not installed or is off-line is not listed in the display. For example, no diskette in DUA2 or an unformatted diskette in DUA2 labels DUA2 as off-line and no display for DUA2 is listed. If there are two question marks on the controllers line, replace the system module. If there is a single question mark on the drive's line, there is a soft error in the drive and the drive may operate normally. Two question marks on the drive's line indicate a hard error in the drive or an error in the controller. You must replace one or both to fix the error. Two question marks for DUA2 may also indicate bad media on the floppy diskette.

**Figure 2-11: Example of System Exerciser Display for the Disk Controller**

```
.  
. .  
7 0090    HDC      1000.0001    2    0 00:02:09.47  
                0700.0001  
                1700.0001  
                2500.0001  
. .  
.
```

[Table 2-7](#) lists the error codes for the disk controller's line and [Table 2-8](#) lists the error codes for the drives.

**Table 2-7: HDC Disk Controller System Exerciser Error Codes**

<b>Error Codes</b>	<b>Possible Cause</b>	<b>Corrective Action</b>
X000.0001	The X indicates the drive used for the data transfer test	0 = DUA0, 1 = DUA1, 2 = DUA2, and F = no data transfer test was done.
0X00.0001	Data transfer error if X is anything other than zero	Replace the system module. If the error still exists after replacing the system module, replace the drive that was used for the data transfer test. Always replace the drive's device electronics board (hard disk drives only) before replacing the whole drive.
00XX.0001	The XX indicates the number of errors detected during the data transfer test. Make note of the drive used for the data transfer test.	Run the exerciser again. Was the same drive used for the transfer test? If yes, and the number of transfer errors are the same (or dose to the same), replace system module. Replace the drive that was used for the data transfer test if replacing the system module did not fix the problem. If no, and the number of transfer errors are zero, replace the drive that got errors during the data transfer test. Always replace the dxive's device electronics board (hard disk drives only) before replacing the whole drive.
0000.XXX1	Controller error.	If XXX is anything other than 000 (three zeros), replace the system module.

**Table 2-8: HDC Disk Drive System Exerciser Error Codes**

Error Codes	Possible Cause	Corrective Action
X000.0001	The X position indicates the drive that this error code is for.	0 = DUA0, 1 = DUA1, and 2 - DUA2.
0X00.0001	The X position indicates the drive Status.	The X position indicates drive status as listed below. DUA0 and DUA1: 7 writeable, formatted, UIB and RCT ok 5 writeable, formatted, no UIB and RCT 4 writeable, unformatted, no UIB and RCT 3 non-writeable, formatted, UIB and RCT ok 1 non-writeable, formatted, no UIB and RCT 0 non-writeable, unformatted, no UIB and RCT DUA2: 5 writeable and formatted 4 writeable and unformatted 1 non-writeable and formatted 0 non-writeable and unformatted
00XX.0001	The XX position indicates the drive error count. 00 indicates no error.	Run the exerciser again. Note the error count for the failing drive after each pass. If the count stays the same or increases, replace the failing drive. If the error still exists after replacing the drive, replace the system module. Always replace the drive's device electronics board (hard disk drives only) before replacing the whole drive.
0000.XXX1	The XXX position indicates the error codes for the drive. 000 indicates no error.	If anything other than zeros (0001), replace the system module. Replace the drive if replacing the system module did not fix the problem. Always replace the drive's device electronics board (hard disk drives only) before replacing the whole drive.

### 2.4.9.3 Troubleshooting the Hard Disk Drive Expansion Box

Troubleshoot the hard disk in the expansion box (DUA1) using self-test and the system exerciser. However, if the diagnostic tests indicate an error on DUA1, perform the steps in the following procedure.

1. Check to make sure the expansion box has power to it and it is switched on.
2. Check to make sure the hard disk cable is properly connected to port B on the expansion adapter and the back of the expansion box.
3. Run the tests again and if the status code shows DUA1 to be off-line, troubleshoot the power supply in the expansion box.
4. Disconnect the cable from port B on the expansion adapter and run self-test (TEST 6). If any status other than the off-line indication (7) or the not tested indication (F) shows up in the status code for DUA1, then replace the disk controller on the system module.
5. If the status code does show that DUA1 is off-line after disconnecting it from port B, check the drive select jumpers on DUA1 for proper positioning. Refer to [Paragraph 2.4.9.4](#) below for proper drive select jumper settings.
6. If the drive select jumper is set properly, replace DUA1 in the disk expansion box. Always replace the drive's device electronics board before replacing the whole drive.

### 2.4.9.4 Drive Select Jumper Settings on Disk Drives

DUA0 – Refer to [Figure 2-12](#) to set the drive select jumper on an RD32 in the system box. Refer to [Figure 2-13](#) to set the drive select jumper on an RD53 in the system box.

DUA1 – Refer to [Figure 2-13](#) to set the drive select jumper on an RD53 in the expansion box.

DUA2 – Refer to [Figure 2-14](#) to set the drive select jumper on an RX33 in the system box.

**Figure 2-12: RD32 Drive Select Jumper Setting for DUA0**

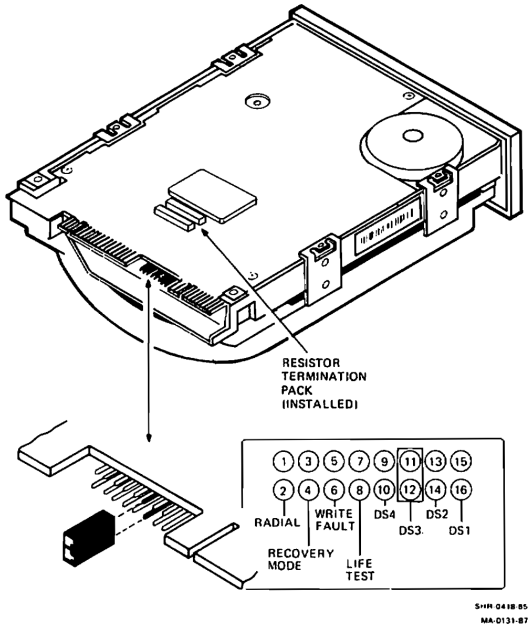

**Figure 2-13: RD53 Drive Select Jumper Setting for DUA0 and DUA1**

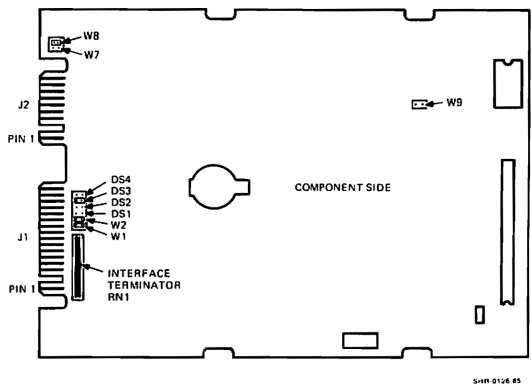

**Figure 2-14: RX33 Drive Select Jumper Setting for DUA2**

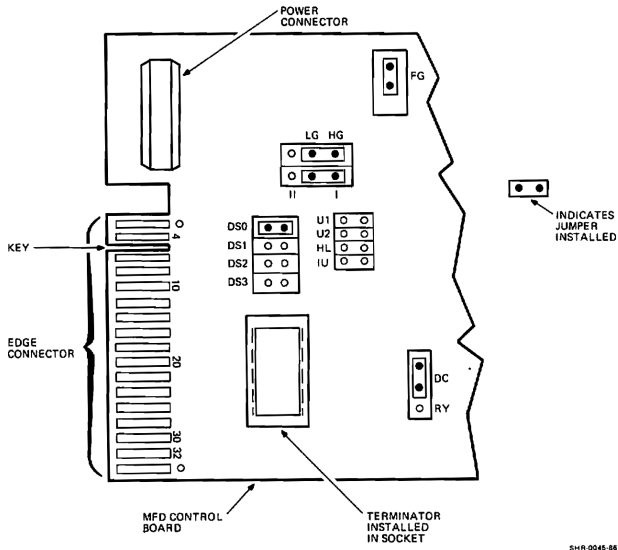

544R-0045-06

## 2.4.10 TPC – Tape Drive Controller Troubleshooting Procedures

You can troubleshoot the tape drive Controller on the system module and the tape drive controller in the expansion box using self-test or the system exerciser. The tape drive expansion box has an internal self-test to troubleshoot the TK50 tape drive as described in [Paragraph 2.4.10.3](#).

These troubleshooting procedures assume that only one tape expansion box is connected to the tape port (port A) on the expansion adapter. Although the diagnostic firmware located in ROM supports up to seven devices on port A of the expansion adapter, we will only cover how to troubleshoot one tape expansion box since the VMS and ULTRIX operating systems support only one tape expansion box on either system. Also, the tape expansion box must be configured for ID address 1 on the tape port.

### 2.4.10.1 Self-test

To run self-test, enter TEST 6. Self-test gives a quick status of the tape controller on the system module and also the tape drive expansion box connected to the tape controller via port A of the expansion adapter. You can run self-test in either

customer mode or field Service mode since both modes test these devices the same. Enter TEST 50 to see the results of the self-test. The TPC error code contains the test results of the tape controller on the system module and the tape drives connected to port A on the expansion adapter. Figure 2-15 shows how the TPC error code is broken into five segments: ID addresses of devices connected to the tape port, ID addresses of the devices that tested successfully, two possible cause indicators, and a status of the tape controller.

**Figure 2-15: TPC Power-up and Self-test Error Code**

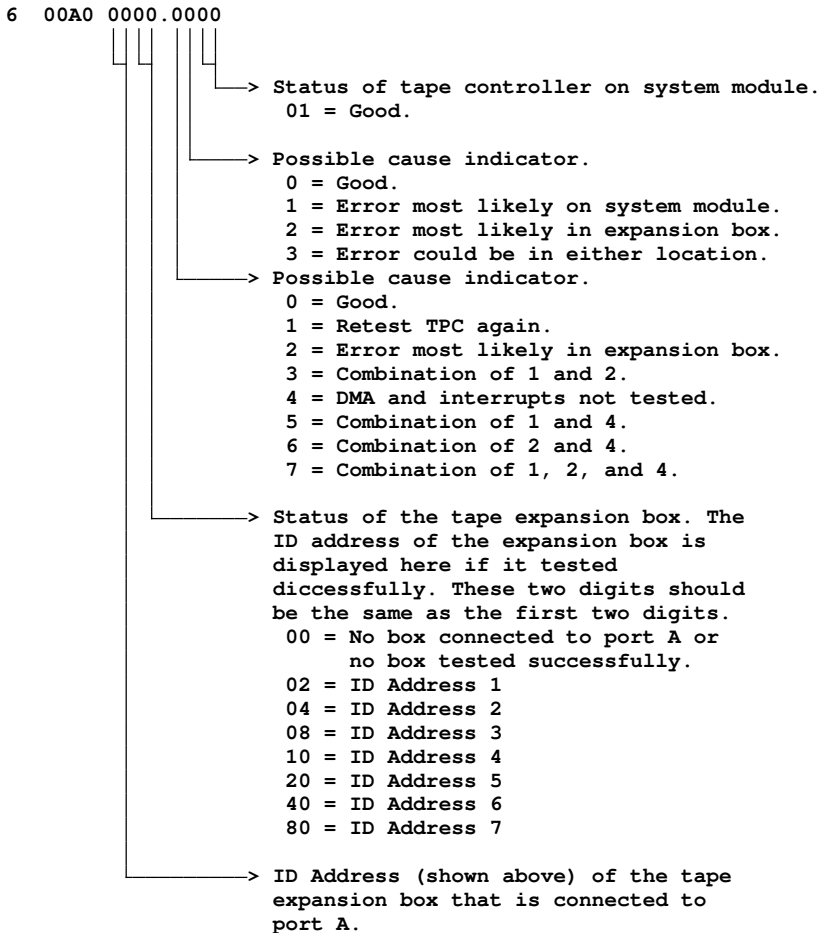

A status code of 0000.4001 indicates a good status for the tape controller when no devices are connected to port A. If there is a tape expansion box connected to port A and the status code is 0000.4001, then the controller does not recognize it or it is not powered up.

If the second two digits of the status code shown in [Figure 2-15](#) (good devices) do not match the first two digits (connected devices), then there is a communication problem between the tape expansion box and the system. Disconnect the cable from port A on the expansion adapter and run self-test again. If the status code for TPC now contains anything other than 0000.4001, replace the system module. Otherwise, if the status code is 0000.4001, reconnect the cable to port A and make sure the tape expansion box is powered up. Run self-test again. If the status code for TPC is not 0202.0001 after reconnecting the cable, run the system exerciser to thoroughly test the tape controller and the tape expansion box. If the error code is 0202.0001 after reconnecting the tape expansion box, the tape Controller and the expansion tape box are operating properly. Note that there may be more than one tape expansion box on systems that run an operating system other than VMS or ULTRIX. This means that the status code may be 0606.0001 for two devices at ID address 1 and 2 or FEFE.0001 for all seven devices connected to the tape port. However, if the system does use VMS or ULTRIX, the tape expansion box at ID address 1 is the only device VMS and ULTRIX can communicate with.

#### **2.4.10.2 System Exerciser**

Start the system exerciser by entering TEST 0 for customer mode or install the 25-pin loopback on the communications port, load the COMPACTape cartridge with the special-key into the TK50, and enter TEST 101 for field Service mode. The customer mode system exerciser does not exercise the tape controller as thoroughly as the field Service exerciser. The field Service mode system exerciser performs a complete read/write test on the TK50 tape drive and also performs a data transfer test while the customer mode system exerciser does not test the TK50 tape drive at all.

The system exerciser runs a first pass test on MONO (VAXstation only), DZ, MEM, and HDC before it runs the first pass test on the TPC. The first pass test on the TPC tests the tape controller on the system module and checks the tape port for the presence of a tape expansion box only if the tape Controller is operating properly. If the tape controller on the system module tests bad, the error code for the tape controller lists an error and the tape port is not checked for the presence of the tape expansion box. The first pass test of the TPC does not perform any diagnostics or data transfer tests on the tape expansion box. The first pass test only checks whether or not the tape expansion box is there and whether or not it can communicate over the tape port to the tape controller. Complete data transfer and read/write (field Service mode only) testing is done on subsequent test passes. For example, in field Service mode with the Special keyed COMPACTape cartridge installed, the error code for the tape expansion box shows that the TK50 is not

writeable (1100.0001) during the first pass. However, the second pass shows that the TK50 is writeable (1300.0001) as long as the cartridge has a good Special key on it and the tape expansion box is operating properly. So you must wait for the system exerciser to complete at least two passes on the TPC to see if the tape expansion box is operating properly.

Figure 2-16 shows the system exerciser display for the TPC. There is one line for the status of the tape controller on the system module and one line for each tape expansion box connected to the tape port if it is powered up. The status of the tape controller is next to the TPC mnemonic (first line) and the status of the tape expansion box is listed under the status of the controller. An easy way of determining if any errors are detected is by looking for the question marks in the left column. If there are any question marks on the tape controllers status line, the tape controller is faulty and the error code identifies the problem. Refer to Table 2-9 to decipher the tape controllers error code and determine how to fix the problem. If there are any question marks on the tape expansion box's status line, the problem could be in either the tape expansion box, the tape expansion box cable, or the tape controller on the system module. An error that is listed in the tape expansion box's error code may be a data transfer error and thus does not isolate the problem to the tape expansion box; it may still be in the tape controller on the system module. Refer to Table 2-10 to decipher the tape expansion box's error code and determine how to fix the problem.

If errors are detected with the TPC, disconnect the tape expansion box cable from port A on the expansion adapter and run the test again. This procedure isolates the tape expansion box from the system box. If any errors appear in the tape controllers error code, the problem is with the tape controller and the system module must be replaced. Otherwise, the error is in the expansion box and you must run the internal self-test on the expansion box as described below.

**Figure 2-16: Example of System Exerciser Display for the Tape Controller**

```

.
.
.
6  00A0    TPC      1000.0001    2    0 00:03:18.26
                        1300.0001
.
.
.

```

Table 2-9 lists the system exerciser error codes for the controller's error line and Table 2-10 lists the system exerciser error codes for the tape drives error line.

**Table 2-9: TPC Tape Controller System Exerciser Error Codes**

<b>Error Codes</b>	<b>Possible Cause</b>	<b>Corrective Action</b>
X000.0001	This error code indicates no Controller error. The X indicates the transfer test drive number.	The X position indicates the tape drive that was used for data transfer testing. This number should be 1 if a tape expansion box is connected to the system and it is powered up. This number should be 8 if no tape expansion box is connected or if it is turned off. An F will always be in this position during the first pass of the exerciser. If the P is still in this position after the first pass is complete, a fatal error is detected in the tape controller on the system module and the tape expansion box is not tested.
0X00.0001	The X indicates a data transfer error if X is anything other than zero.	Replace the system module. If the error still exists, replace the TK50 tape drive. Then if the error code still exists, replace the TZK50 controller board.
00XX.0001	The XX indicates the number of data transfer errors detected. Make a note of the tape drive used for the data transfer test.	Run the exerciser again. Was the same drive used for the transfer test? If yes, and the number of transfer errors are the same (or close to the same), replace the system module. If no, and the number of transfer errors are zero or considerably less than before, replace the TK50 drive that was originally used for the transfer test. If the error code still exists, replace the TZK50 controller board.
0000.XXX1	Controller error if any X is anything other than zero.	Replace the system module.

**Table 2-10: Tape Drive Expansion Box System Exerciser Error Codes**

Error Codes	Possible Cause	Corrective Action
X000.0001	The X indicates the device ID address of tape expansion box.	This device ID address can be 1, 2, 3, 4, 5, 6, or 7. It should normally be 1 unless the device ID address jumpers (P1, P2, P3) on the TZK50 controller board have been changed. It must never be 0. If a 0 is in this position, the device ID address jumpers are set to zero and they must be reset to another ID. The ID address must be 1 for systems running VMS or ULTRIX.
0X00.0001	The X indicates the tape cartridge status.	The X position indicates whether or not the device on the tape port has removeable or non-removeable media and also whether or not the device is writeable. 1 = removeable media, 2 = writeable, and 3 = removeable media and it is writeable. This digit should be a 1 or a 3 since the TK50 has removeable media. This digit should be a 1 in customer mode and a 3 in field Service mode if the special-keyed cartridge is installed and loaded in the TK50. Note that this digit can never be a 3 in field Service mode until a second pass test is done on the TPC since the system exerciser does not do a write test on the first pass.
00XX.0001	The XX indicates the drive error count during the data transfer test. 00 indicates no error.	The error may be in the TZK50 controller board, the TK50 tape drive, or the tape controller on the system module. Run the exerciser again but with another tape expansion box, if possible, to determine if the error is on the tape controller or in the tape expansion box you removed. If the data transfer error still appears after replacing the tape expansion box, replace the system module. Otherwise, troubleshoot the tape expansion box as shown in <a href="#">Paragraph 2.4.10.3</a> below. If you do not have an other tape expansion box to swap out, replace the following FRUs one at a time and run the exerciser after each one is replaced until there are no more transfer errors. First, TZK50 controller board; second, TK50 tape drive; third, the system module. Remember that the TK50 tape drive is not tested in customer mode and is also not tested in field service mode if the special-keyed tape cartridge is not loaded in the TK50 tape drive.

**Table 2-10 (Cont.): Tape Drive Expansion Box System Exerciser Error Codes**

Error Codes	Possible Cause	Corrective Action
0000.XXX1	The XXX indicates the error codes. 000 indicates no errors.	If anything other than zeros (.0001) appear, Run the exercdser again but with another tape expansion box, if possible, to determine if the error is on the tape controller or in the tape expansion box you removed. If the error still appears after replacing the tape expansion box, replace the system module. Otherwise, troubleshoot tne tape expansion box as shown in <a href="#">Paragraph 2.4.10.3</a> below. If you do not have another tape expansion box to swap out, replace the following FRUs one at a time and run the exerciser after each one is replaced until there are no more transfer errors. First, TZK50 controller board; second, TK50 tape drive; third, the system module. Remember that the TK50 tape drive is not tested in customer mode and is also not tested in field service mode if the special-keyed tape cartridge is not loaded in the TK50 tape drive.

### 2.4.10.3 Troubleshooting the Tape Expansion Box

If the results for the TPC indicate a problem in the tape expansion box, the problem could be the TK50 tape drive, the TZK50 controller board, or the power supply. The TK50 tape drive performs an internal self-test every time the tape expansion box is powered up. The TZK50 controller also performs an internal self-test at power up. To do an in-depth self-test on the TK50 tape drive and the TZK50 controller board, follow the procedure below. Do each step indicated until you find and fix the problem.

1. Remove the tape drive expansion box cover.
2. Check all cables to make sure they are connected properly. Remove the shield to check the cables on the back of the drive. Note that there are two power cables connected to the resistor load board.
3. Check the jumpers on the TZK50 controller board for proper installation. Refer to [Figure 2-17](#) for jumper locations and tape port ID address confirmation. [Figure 2-17](#) shows the controller board set for ID address 1, with parity checking enabled, and internal diagnostics disabled. Make sure the three ID address jumpers (P1, P2, and P3) are set to ID address 1. Jumper P4 is the parity checking jumper and must be installed for normal operation. Jumper P5 is the diagnostic jumper and must not be installed for normal operation. Note the position of the spare jumper(s). Spare jumpers should be stored across P5 and one of the spare posts.
4. Check the three resistor network packs (Z7, Z6, and Z5) to make sure they are installed properly. If this expansion box is the only box connected to the tape port, these resistor network packs must be installed on this board. If this expansion box is not the only box connected to the tape port, then make sure

the last box in the chain contains these resistor network packs and all other boxes in the chain have their resistor network packs removed.

5. Plug in the power cord and switch on power to the expansion box.
6. If the LED on the TZK50 controller board and on the TK50 tape drive do not light when power is first turned on or the fan does not turn, troubleshoot the power supply ([Paragraph 2.4.13](#)).
7. Watch the red light on the TK50 tape drive. It should shut off after five to six seconds after power up if no tape is installed. If it starts flashing, replace the TK50 tape drive. When a tape is installed, the red light stays lit.
8. Look at the LED on the TZK50 controller board. It turns on at power up, then turns off after two seconds. It must stay off once it turns off. If it does not stay off, replace the TZK50 controller board.
9. Insert and load a blank COMPACTape cartridge into the TK50 tape drive. Do not use the special-keyed cartridge from the kit or a cartridge that has good data, because the next few steps will erase the special key and the data on the cartridge. If you must use the special-keyed cartridge, reload the special key onto the cartridge using TEST 73 after you complete this procedure.
10. Switch off power to the expansion box.
11. Remove a spare jumper and install it onto P5. If there are two spare jumpers then both must be removed from their storage positions so one of them can be installed onto P5.
12. Switch on the power switch.
13. Wait about one minute for the test to finish. If the LED on the TZK50 controller board starts flashing during or at the end of the test, replace the TK50 tape drive. If the LED is on steady, replace the TZK50 Controller board. If the LED is off, the TZK50 controller board and the TK50 tape drive are operating properly. Note that the LED comes on again at the end of the test for about two seconds to indicate that the testing cycle has completed and is starting over again. The test will continue to cycle until the P5 diagnostic jumper is removed or power is switched off.

Reverse the procedure in Paragraph 3.12.1.

**Figure 2-17: TZK50 Controller Board Jumper Locations**

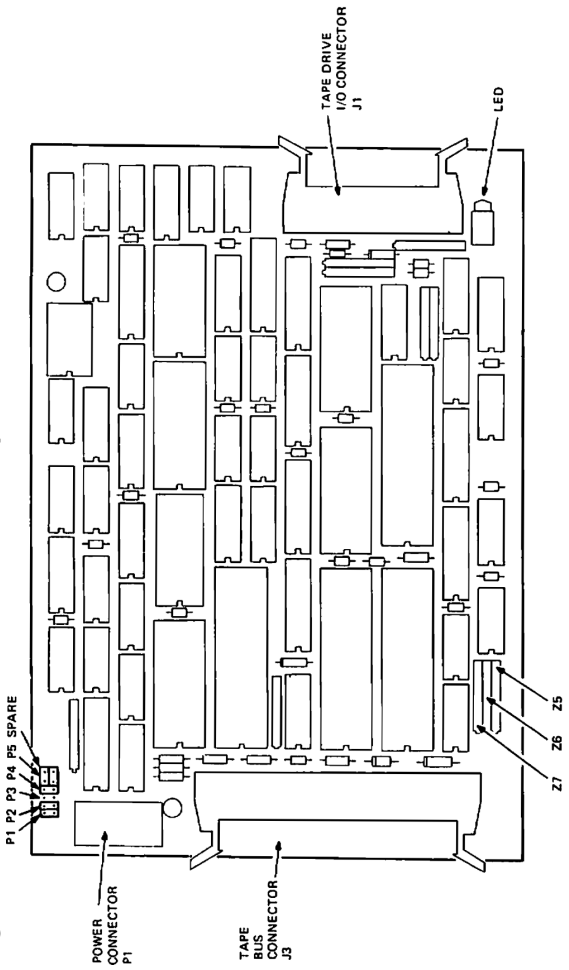

ADDRESS ID	P 1	P 2	P 3
0	Installed	Installed	Installed
1	Installed	Installed	Removed
2	Installed	Removed	Installed
3	Installed	Removed	Removed
4	Removed	Installed	Installed
5	Removed	Installed	Removed
6	Removed	Removed	Installed
7	Removed	Removed	Removed

14. Replace the faulty component, if any, and retest.
15. Set up the jumpers on the TZK50 controller board for normal operation. Spare jumpers must be stored across P5 and one of the spare posts.
16. This concludes the troubleshooting procedures for the tape expansion box.

## **2.4.11 SYS – Interrupt Controller and ThinWire Ethernet ID ROM Troubleshooting Procedures**

You can troubleshoot the interrupt controller and ThinWire Ethernet ID ROM (SYS) in either customer mode or field service mode. Both modes test these circuits the same.

### **2.4.11.1 Self-test**

To run self-test, enter TEST 5. Any error code other than 0000.0001 or 0000.0100 indicates a fault in the interrupt Controller or the ThinWire Ethernet ID ROM on the system module. The 0000.0100 error code indicates that the keyboard is disconnected from the VAXstation 2000 systems. Replace just the ThinWire Ethernet ID ROM on the system module to fix an error code of 0000.0004. Replace the system module to fix any other error code. The replacement procedure for the system module instructs you to remove the Thinwire Ethernet ID ROM from the system module being removed and install it onto the new system module. If the ThinWire Ethernet ID ROM has been replaced for an error code of 0000.0004 and the same error code of 0000.0004 reappears when you retest, replace the system module instead of just the ThinWire Ethernet ID ROM.

The system exerciser does not display the status of the SYS circuits. The SYS circuits are not directly tested but are tested through the testing of other circuits.

## 2.4.12 NI – ThinWire Ethernet Network Option Troubleshooting Procedures

You can troubleshoot the ThinWire Ethernet network option (NI) in either customer mode or field service mode. Both modes of self-test test the network option the same. The field service mode of the system exerciser does a more in-depth testing of the option. To troubleshoot the network option, run self-test (TEST 1) or run the system exerciser (TEST 0 for customer mode or TEST 101 for field service mode).

Self-test and the system exerciser test the network interconnect module, the ThinWire transceiver circuits on the system module, and also perform a loopback function on the ThinWire cable. All tests fail with an error code of 0000.7004 if the ThinWire cable is not connected to the back of the System box. An error code of 0000.7008 indicates the ThinWire cable is not terminated properly. Check the ThinWire cable first if any error code has a number seven in the fifth position (0000.7000). The seven in the fifth Position indicates a loopback error, but it does not exclude a problem on the network option inside the system box. An error code of 0000.0001 indicates no error and the network option is operational.

### 2.4.12.1 Self-test

To run self-test, enter TEST 1. Any error code other than 0000.0001 indicates a fault in either the network interconnect module or on the ThinWire Ethernet cable. Note that positions 3 and 4 (00XX.0001) in the error code indicate the number of retries over the Ethernet cable before a success. If the error code is not 0000.0001, check the ThinWire Ethernet cable on the back of the system for proper connections and terminators. Reconnect the Thinwire cable and terminators, if disconnected, and test again. If the error code is 0000.7000 or above (for example, 0000.7001 or higher), disconnect the ThinWire T connector from the back of the system and install the T connector with terminators from the service kit. Run the test again. If the error code is 0000.0001 after installing the T connector with both terminators, the problem is on the ThinWire Ethernet cable. Otherwise, if the error code is anything other than 0000.0001, replace the network interconnect module and test again with the T connector and both terminators installed. If the error code is still not 0000.0001 after repladng the network interconnect module, replace the system module.

### 2.4.12.2 System Exerciser

To run the system exerciser, enter TEST 0 for customer mode or TEST 101 for field service mode. Field service mode does a more in-depth test of the circuits. Any error code other than 0000.0001 indicates a fault in the network interconnect module or on the system module. Unlike the self-test for the network Option, the system exerciser does not do any testing over the ThinWire Ethernet cable. It only tests the internal circuitry. If the error code is not 0000.0001, replace the network interconnect module. If the error code is still not 0000.0001 after replacing the

network interconnect module, replace the system module.

## 2.4.13 Power Supply Troubleshooting Procedures

Follow the flowchart in [Figure 2-18](#) if a problem with the power supply in either the system box, hard disk expansion box, or tape drive expansion box exists. The flowchart is designed to troubleshoot the power supply in any of the three boxes.

**Figure 2-18: Flowchart for Troubleshooting the Power Supply**

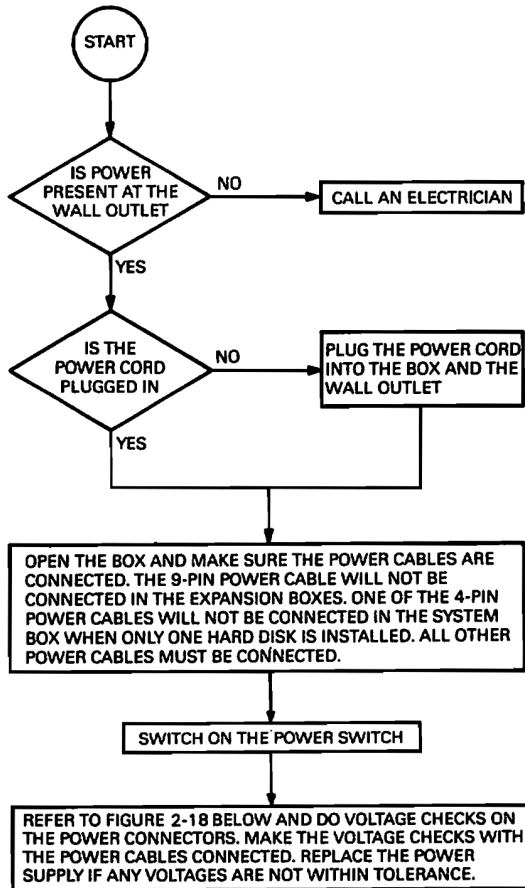

MA-0066-87

**Figure 2-19: Power Connectors Pin Voltages**

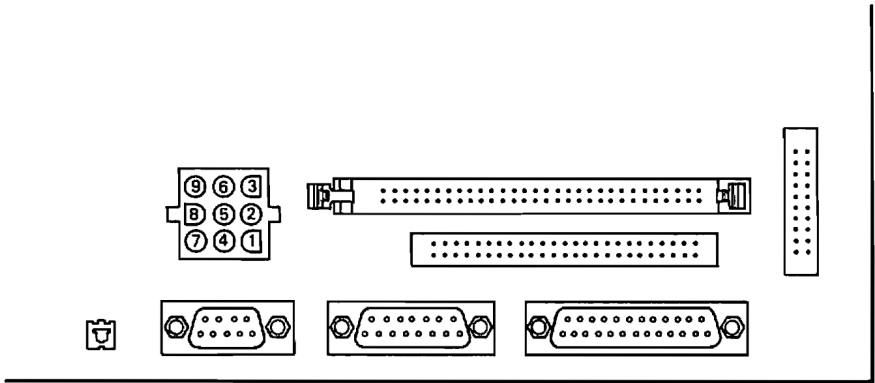

**CHECK VOLTAGE LEVELS WITH THE POWER CABLES CONNECTED!**

PIN	VOLTAGE
1	GROUND
2	GROUND
3	GROUND
4	-12.0 Vdc    -0.6 Vdc
5	5.1 Vdc        -0.25 Vdc
6	5.1 Vdc        -0.25 Vdc
7	12.1 Vdc      -0.60 Vdc
8	9.0 Vdc TO PIN 9
9	9.0 Vdc TO PIN 8

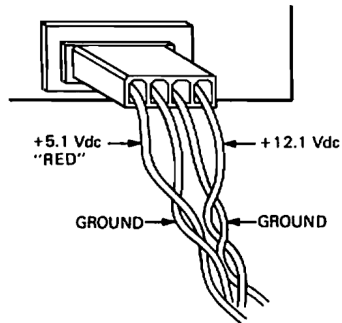

MR-1286-1412  
MA-0156-87

## 2.4.14 VR260 Monochrome Monitor Troubleshooting Procedures

Table 2-11 lists some Symptoms of common problems with the VR260. When troubleshooting the VR260, follow the suggested corrective actions in the order listed.

**Table 2-11: VR260 Troubleshooting Table**

Symptom	Corrective Action
No LED; blank screen.	<p>Check the power cord connection.</p> <p>Check the 120/240 Vac setting.</p> <p>Check the fuse.</p> <p>Remove the rear bulkhead assembly and check the connection to the transformer assembly.</p> <p>Check the deflection board connections.</p> <p>Replace the deflection board connections.</p>
Flashing LED.	<p>Check the deflection board connections, including the chassis ground.</p> <p>Make sure the high-voltage anode lead has a good connection with the CRT.</p> <p>Replace the deflection board.</p>
Compressed raster; no video display.	<p>Make sure the monitor cable is connected between the system and the monitor.</p> <p>Adjust the contrast and brightness adjustments.</p> <p>Run the monochrome video diagnostics (TEST F). If a failure is indicated, replace the System module in the system box before proceeding with troubleshooting the VR260.</p> <p>Remove the rear bulkhead assembly and check the cable connections to the video amp board.</p> <p>Remove the video amp board and check the CRT pin connections.</p> <p>Replace the video amp board.</p>
Raster; no video display.	<p>Run the monochrome video diagnostics (TEST F). If a failure is indicated, replace the system module in the System box before proceeding with troubleshooting the VR260.</p> <p>Ensure good CRT connections.</p> <p>Replace the video amp board.</p>

**Table 2-11 (Cont.): VR260 Troubleshooting Table**

Symptom	Corrective Action
No LED but good video display.	Remove the LED bezel assembly and check for a good connection.  Replace the LED.  Ensure proper cable connections fr.om.the deflection board to the LED bezel assembly.
Video display but not to specifications.	Bring up the appropriate monochrome display alignment pattern (TESTS 60, 61, or 62) and perform the adjustment according to <a href="#">Chapter 4</a> .

## 2.4.15 Terminal Communication Troubleshooting Procedures (MicroVAX 2000 only)

If you are having communications problems on a terminal, follow the flowcharts starting at [Figure 2-20](#). If you have performed the loopback test on the terminal and the terminal passed the tests, follow the flowcharts starting at [Figure 2-21](#).

**Figure 2-20: Flowchart for Troubleshooting Terminal Communications**

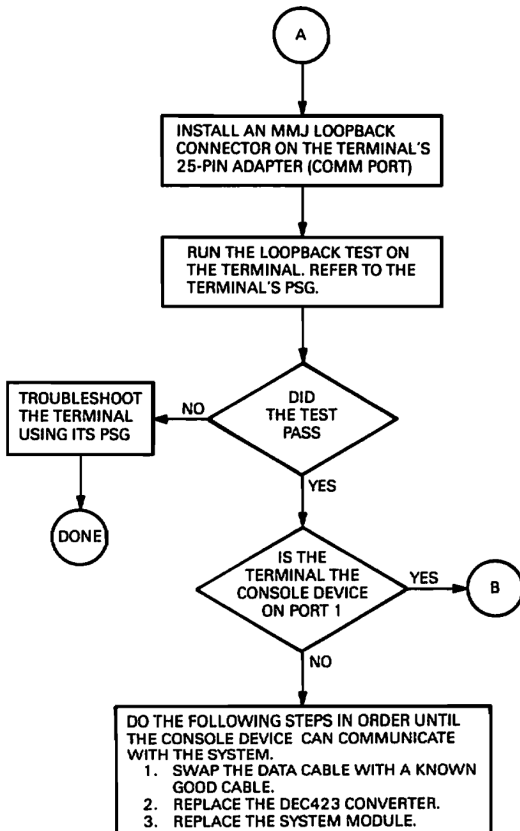

MR-1286-1408  
MA-0087-87

**Figure 2-21: Flowchart for Troubleshooting Terminal Communications on the DEC423 Converter**

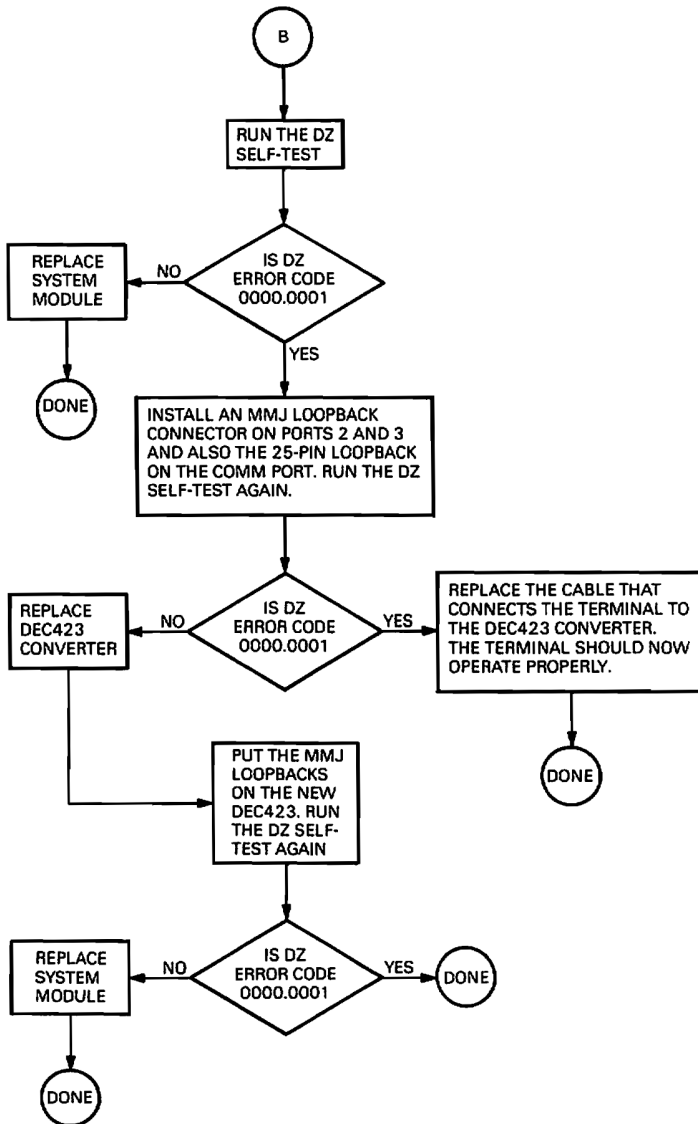

MR-1286-1407  
MA-0068-B7

## 2.5 Utilities

The Utilities help the user format a hard disk, set default and restart flags, and display alignment patterns on VAXstation 2000's monitors as well as other functions. Each utility is described below and is available on VAXstation 2000 and MicroVAX 2000 unless otherwise noted. [Table 2-12](#) lists the console mode TEST commands that invoke the Utilities.

**Table 2-12: Utilities**

Test Number	Description of Utility
50	Configuration table
51	Set NVR default Boot device
52	Set NVR default Boot flags
53	Set NVR default recovery action flags
54	Language inquiry menu
60	Monochrome circle cross-hatch alignment pattern (25-pin loopback (p/n 29-24795) must be installed)
61	Monochrome screen of E's
62	Monochrome white screen
70	Mass storage disk formatter
71	Mass storage verifier
72	Special key on floppy diskettes for field service system exerciser (25-pin loopback (p/n 29-24795) must be installed)
73	Special key on TK50 COMPACTapes for field service system exerciser (25-pin loopback (p/n 29-24795) must be installed)
80-8F	Reserved for future option utilities
90	Network test utility

## 2.5.1 Configuration Table

The configuration table lists the Status of each device installed in the system. This configuration table holds the results of the self-test and power-up tests and is updated each time self-test is run. See [Figure 2-22](#) for an example of a configuration table. The error codes for each device in the configuration table are explained in the troubleshooting section for that individual device. Remember that the configuration table contains the results of the self-test and power-up tests and not the results of the system exerciser.

**Figure 2-22: Example of the Configuration Table**

```
>>> TEST 50

KA410-A V1.0
ID 08-00-2B-02-CF-A4

MONO      0000.0001
CLK       0000.0001
NVR       0000.0001
DZ        0000.0001
          00000001 00000001 00000001 00000001 00000001 000012A0
MEM       0002.0001
          00200000
MM        0000.0001
FP        0000.0001
IT        0000.0001
HDC       1110.0001
          000146B8 0028173 00000320
TPC       0202.0001
          FFFFFFF03 01000001 FFFFFFF05 FFFFFFF05 FFFFFFF05 FFFFFFF05 ...
SYS       0000.0001
NI        0000.0001 v1.0

>>>
```

The first line contains the CPU and the ROM version (KA410-A V1.0). The second line contains the ThinWire Ethernet hardware address (in this example it is ID 08-00-2B-02-CF-A4). The rest of the display contains the error codes for the devices installed on the System. The configuration table is built during power-up testing and the error codes are the result of the self-test and power-up tests. This configuration table is the only place the results of self-test are indicated. It is updated every time self-test is run. Additional codes on the DZ, MEM, HDC, TPC, and NI give a more detailed status on these devices as listed below.

### 2.5.1.1 DZ Explanation in Configuration Table

The DZ has six 8-digit numbers that contain the status of the four serial lines, the keyboard, and the mouse or tablet. Any 8-digit number other than 00000001 for the first five status codes indicates a failure. A status code of 00000000 for the keyboard indicates that the keyboard is disconnected. The sixth 8-digit number is anything other than 000012A0 (good status) or 00000000 (nothing connected) indicates a failure in the device connected to the monitor cable. The MicroVAX 2000 does not use the last two 8-digit numbers and 00000000 is the normal display for the MicroVAX systems. [Figure 2-23](#) shows what each 8-digit number represents.

**Figure 2-23: Example of the DZ Line in the Configuration Table**

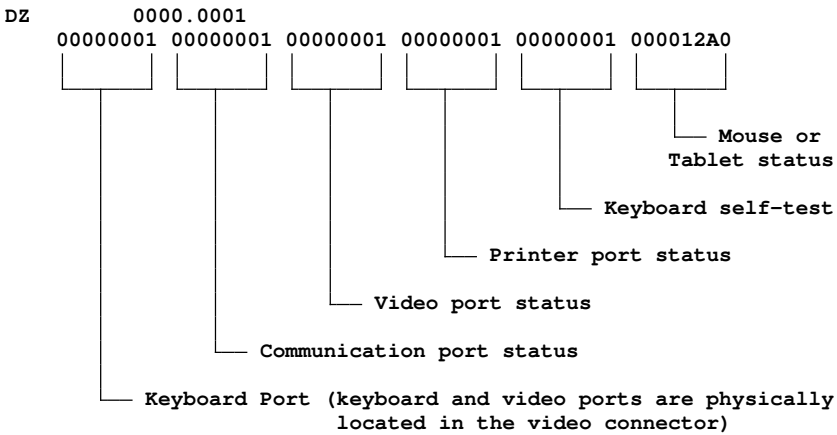

### 2.5.1.2 MEM Explanation in Configuration Table

The MEM has one 8-digit number that contains the amount of physical memory in the system. This number is in hexadecimal. For example, 00200000 indicates that at least 2 megabytes of memory is in the System. If there is an error in the memory, however, a second 8-digit number that contains the location of the failed memory is displayed. [Figure 2-24](#) shows the second 8-digit number of the MEM display in the configuration table. The 3 in the last digit indicates the error is on the system module. Only the last digit needs to be explained because if any of the other seven digits are anything other than 0 (zero), then an error is on the memory option module. [Table 2-13](#) lists whether the system module or memory option module is faulty according to the last digit in the second 8-digit number.

**Figure 2-24: Example of MEM Error Display in the Configuration Table**

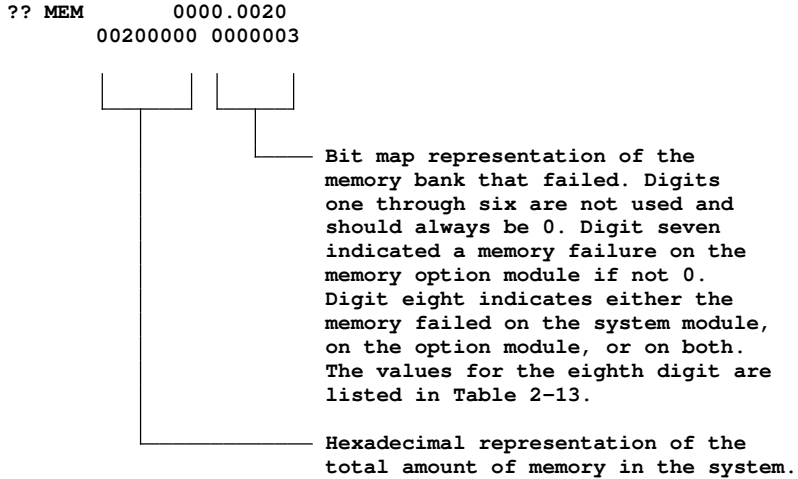

**Table 2-13: Determining the Location of the Failing Memory Bank**

Error Codes	System Module	Option Module
0		
1	X	
2	X	
3	X	
4		X
5	X	X
6	X	X
7	X	X
8		X
9	X	X
A	X	X
B	X	X
C		X
D	X	X
E	X	X
F	X	X

### 2.5.1.3 HDC Explanation in Configuration Table

The HDC has three 8-digit numbers that contain the megabyte size of the hard disk drives and of the floppy diskette in the floppy drive. Figure 2-25 shows the status codes that contain the sizes of the drives. The amount of megabytes may be different for each drive because one drive may have more revectorred bad blocks than another.

**Figure 2-25: Example of the Second HDC Line in the Configuration Table**

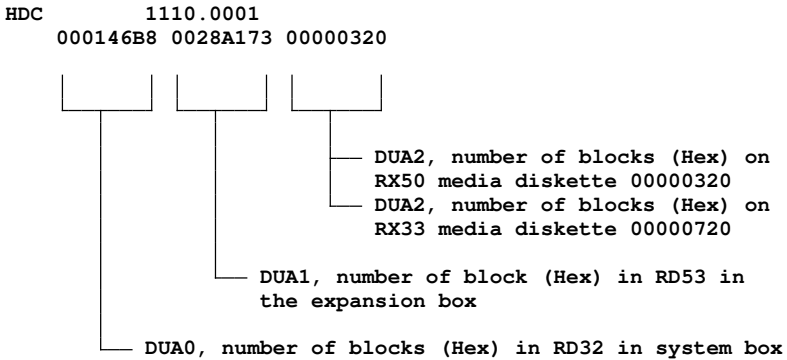

### 2.5.1.4 TPC Explanation in Configuration Table

The TPC has eight 8-digit numbers as shown in [Figure 2-26](#). The example in [Figure 2-22](#) shows only six 8-digit numbers for lack of space. Each of the 8-digit numbers contain the status of the devices connected to the tape port (port A on the expansion adapter). Up to seven devices can be connected to the tape port, but VMS and ULTRIX only support one tape expansion box. The tape Controller on the system module always holds ID address 0 as shown in [Figure 2-26](#) by the FFFFFFF03 code in ID 0. ID address 1 contains a status code of 01000001 to indicate that the tape expansion box connected to the tape port is at this address and it has no errors. The status code 01000001 is the good status code for the tape expansion box only, not for any other type of device that the customer may have connected to port A (if any). The other ID addresses hold a status code of FFFFFFF05 since, in this example, no more devices are installed at those ID addresses. Normally, when there is only one tape expansion box, it is located in ID address 1. However, the ID address may be changed to any ID address except ID address 0 since ID 0 is the tape Controller on the System module. The TPC troubleshooting procedure shows how the ID address of the expansion box can be changed. [Figure 2-26](#) shows the ID addresses of the 8-digit numbers.

**Figure 2-26: Example of the Second TPC Line in the Configuration Table**

TPC	0202.0001						
FFFFFFF03	01000001	FFFFFFF06	FFFFFFF05	FFFFFFF05	FFFFFFF05	FFFFFFF05	FFFFFFF05
┌───┐	┌───┐	┌───┐	┌───┐	┌───┐	┌───┐	┌───┐	┌───┐
└───┘	└───┘	└───┘	└───┘	└───┘	└───┘	└───┘	└───┘
┆	┆	┆	┆	┆	┆	┆	┆
┆	┆	┆	┆	┆	┆	┆	┆
┆	┆	┆	┆	┆	┆	┆	┆
┆	┆	┆	┆	┆	┆	┆	┆
┆	┆	┆	┆	┆	┆	┆	┆
┆	┆	┆	┆	┆	┆	┆	┆
┆	┆	┆	┆	┆	┆	┆	┆
ID 0	ID 1	ID 2	ID 3	ID 4	ID 5	ID 6	ID 7

**NOTE:** If there are no devices connected to port A, or if they are not powered up, the top line will indicate 0000.4001 with a single question mark for a good indication.

### 2.5.1.5 NI Explanation in Configuration Table

The ThinWire Ethernet network interconnect option module display in the configuration table contains the revision level of the ROM located on the NI module. V1.0 on the NI line in [Figure 2-22](#) indicates the ROM on the network interconnect option module is version 1.

### 2.5.1.6 Determining the Revision Levels in the System Module's ROM

The ROM on the system module contains four separate sections of program code. These sections are the self-test code, console code, VMB code, and the system exerciser code and all have different internal revision levels. Enter TEST 80000050 to see the internal revision levels of the self-test, console, and VMB code displayed next to the KA410-A in the configuration table. An example of these three revision levels is shown in [Figure 2-27](#). The V1.17C is for the self-test revision level, 0BF is for the console revision level, and V1.0 is for the VMB revision level. The revision level of the system exerciser is shown in the system exerciser display when the exerciser is running.

### Figure 2-27: Example of the System Module's ROM Code Revision Levels

```
>>> TEST 80000050

KA410-A V1.17C-0BF-V1.0
ID 08-00-2B-02-CF-A4

MONO      0000.0001
CLK       0000.0001
NVR       0000.0001
.
.
.
```

### 2.5.1.7 Determining the Revision Levels of the Tape Expansion Box's ROMS

The tape expansion box contains two ROMs. One ROM is on the TZK50 controller board and the other ROM is in the TK50 tape drive. Perform the following steps to determine the revision levels of these two ROMs.

1. Power up the tape expansion box.
2. Unload and remove any COMPACTape cartridge from the TK50 tape drive.
3. Enter TEST 73.
4. Enter 1 when the system prompts with VStmk\_QUE\_id (1,2,3,4,5,6,7) ?.
5. Enter 60000001 when the system prompts with VStmk\_QUE\_RUsure (1/0) ?.
6. The screen will scroll fast. Stop the screen from scrolling as soon as the information shown in the example in [Figure 2-28](#).

**Figure 2-28: Example of Tape Port Bus Information**

```
.  
. .  
receive_diagnostic  
command: 1C 00 00 00 50 00  
data_in: 05 1E 00 0A FB 00  
status : 00  
msg_in : 00  
. .  
.
```

7. The data\_in: line holds the revision levels of the ROMs. [Figure 2-29](#) shows the codes that identify the TZK50 firmware/hardware revision and the TK50 firmware/hardware revision levels. These revision level codes are in hexadecimal.

**Figure 2-29: Example of the TZK50 and TK50 ROM Revision Levels**

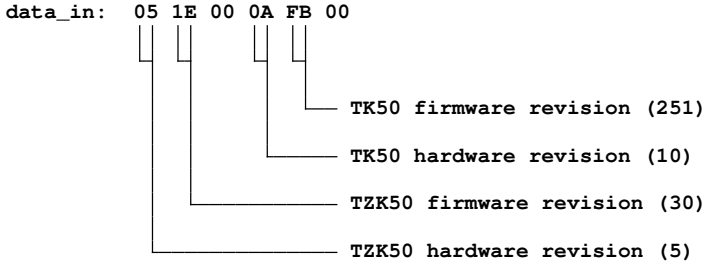

## 2.5.2 Setting NVR Default Boot Device

This utility sets the default boot device in the NVR. There are five boot devices to choose from: DUA0, DUA1, DUA2, MUA0, or ESA0. [Figure 2-30](#) shows an example of changing the default boot device from four periods (...), no default device to DUA1 (RD53 in the expansion box).

**Figure 2-30: Example of Changing the Default Boot Device**

```
>>> TEST 51
      .... ? >>> DUA1
>>>
```

Enter a carriage return to exit TEST 51 without changing the default boot device. Enter a period (.) to clear the default boot device from NVR. Enter the device, such as DUA1, to set the default boot device to that device.

## 2.5.3 Setting NVR Default Boot Flags

This utility sets the default boot flags in the NVR. [Table 2-14](#) lists the boot flags common to all operating systems. [Table 2-15](#) lists additional boot flags that the VMS operating system uses. The boot flags in [Table 2-15](#) has additional definitions for other operating systems. [Figure 2-31](#) shows an example of changing the default boot flag from 00000000 to 00000010 (diagnostic boot). Enter a carriage return to exit TEST 52 without changing the default boot flag.

### Figure 2-31: Example of Changing the Default Boot Flag

```
>>> TEST 52
      00000000 ? >>> 00000010
>>>
```

You can specify one or any combination of boot flags in the NVR. To specify more than one flag, enter the sum value (in hex) of the flags that you want loaded into the NVR. For example, if you want to specify the RPB\$V\_DIAG flag, RPB\$V\_HALT flag, and the RPB\$V\_MPM flag, add all three flags as shown in Figure 2-32 and enter the sum into NVR (TEST 52).

### Figure 2-32: Determining the NVR Code for Three Boot Flags

```
RPB$V_DIAG --- 00000010
RPB$V_HALT --- 00000200
RPB$V_MPM  --- 00000A00
                -----
Enter this code 00000A10
```

**Table 2-14: Boot Flags Used by VMB for Booting All Operating System Software**

Flag	Definition
00000008	RPB\$V_BBLOCK – This skips the files-11 boot and performs only the boot block type boot.
00000010	RPB\$V_DIAG – Diagnostic boot. Secondary bootstrap is image called [SYSMAINT]DIAGBOOT.EXE.
00000020	RPB\$V_BOOBPT – Bootstrap breakpoint. Stops the primary and secondary bootstraps with a breakpoint instruction before testing memory.
00000040	RPB\$V_HEADER – Image header. Takes the transfer address of the secondary bootstrap image from that file’s image header. If RPB\$V_HEADER is not set, transfers control to the first byte of the secondary boot file.
00000100	RPB\$V_SOLICT – File name. Prompt for the name of a secondary bootstrap file.

**Table 2-14 (Cont.): Boot Flags Used by VMB for Booting All Operating System Software**

Flag	Definition
00000200	RPB\$V_HALT – Halt before transfer. Executes a halt instruction before transferring control to the secondary bootstrap.
00001000	RPB\$V_PFILE – (overlays RPB\$V_USEMPM) File name. Prompt for the name of the parameters file on a network bootstrap operation.
X0000000	RPB\$V_TOPSYS – The X position specifies the top level directory number for system disks with multiple systems.

**Table 2-15: Specific Boot Flags Used by VMS**

Flag	Definition
00000001	RPB\$V_CONV – Conversational boot. At various points in the system boot procedure, the bootstrap code solicits parameters and other input from the console terminal. If the DIAG is also on, the diagnostic supervisor then enters "MENU" mode and prompts the user for devices to test.
00000002	RPB\$V_DEBUG – Debug. If this flag is set, VMS maps the code for the XDELTA debugger into the system page tables of the running system.
00000004	RPB\$V_INIBPT – Initial breakpoint. If RPB\$V_DEBUG is set, VMS executes a BPT instruction immediately after enabling mapping.
00000080	RPB\$V_NOTEST – Memory test inhibit. Sets a bit in the PFN bit map for each page of memory present. Does not test the memory.
00000400	RPB\$V_NOFND – No PFN deletion (not implemented; intended to tell VMB not to read a file from the boot device that identifies bad or reserved memory pages, so that VMB does not mark these pages as valid in the PFN bitmap).
00000800	RPB\$V_MPM – Specifies that multiport memory is to be used for the total exec memory requirement. No local memory is to be used. This is for tightly-coupled multiprocessing. If the DIAG is also on, then the diagnostic supervisor enters "AUTOTEST" mode.
00002000	RPB\$V_MEMTEST – Specifies that a more extensive algorithm be used when testing main memory for hardware uncorrectable (RDS) errors.
00004000	RPB\$V_FINDMEM — Requests use of MA780 memory if MS780 is insufficient for booting. Used for 11/782 installations.
00008000	RPB\$V_AUTOTEST - Used by diagnostic supervisor.
00010000	RPB\$V_CRDTEST — Request pages with CRD errors to be removed from bitmap.

## 2.5.4 Setting NVR Default Recovery Action Flags

This utility sets the recovery action flags in the NVR. The default recovery action flag is used by the system during power up and also if the system detects a severe error of its operating environment. There are three flags to choose from: restart, boot, or halt. Restart searches for the restart parameter block (RPB) in memory (the RPB contains addresses of certain registers that hold restart information). Boot starts booting the operating system software. Halt automatically halts the system and enters console mode. [Table 2-16](#) lists the recovery flags available.

**Table 2-16: Default Recovery Flags**

Number	Recovery Action Flag
1	RESTART
2	BOOT
3	HALT

To change the NVR recovery action flag, enter TEST 53. [Figure 2-33](#) shows an example of changing the flag from 2 (boot) to 3 (HALT). Enter a carriage return to exit TEST 53 without changing the flag.

**Figure 2-33: Example of Changing the NVR Recovery Action Flags**

```
>>> TEST 53
      2 ? >>> 3
>>>
```

## 2.5.5 Language Inquiry Menu

This utility is only available on the VAXstation 2000. This utility displays the language inquiry menu on the console device. To choose another language for the keyboard, enter TEST 54 and select the proper language. Hit the return key to obtain the console prompt without changing the language. The terminal on the MicroVAX 2000 has the language menu available in the setup procedures.

## 2.5.6 Circle Cross-Hatch Alignment Pattern

This utility is only available on the VAXstation 2000. This utility sends the circle cross-hatch alignment pattern to the monitor connected to the video port. Enter TEST 60 to display the circle cross-hatch alignment pattern. A loopback (p/n 29-24795) must be attached to the 25-pin communication port to run this utility. Hit the carriage return to stop the display.

## 2.5.7 Screen of E's Pattern

This utility is only available on the VAXstation 2000. This utility sends a full screen of E's to the monitor connected to the video port. Enter TEST 61 to display the screen of E's pattern. Hit the carriage return to stop the display.

## 2.5.8 White Screen

This utility is only available on the VAXstation 2000. This utility sends a full white screen to the monitor connected to the video port. Enter TEST 62 to display the white screen. Hit the carriage return to stop the display.

## 2.5.9 Mass Storage Disk Formatter

This utility formats the hard disk drives and RX33 floppy diskettes. The command to start the formatter is TEST 70. [Figure 2-34](#) shows an example of running the formatter on DUA0. The procedure shown in [Figure 2-34](#) is for all Digital hard disk drives. [Figure 2-35](#) shows an example of running the formatter on an RX33 diskette in DUA2. This formatter cannot format RX50 diskettes. If the hard disk is not a Digital hard disk drive or if it is a hard disk drive that the formatter does not recognize, the formatter goes into a query mode. This query mode allows you to input specific data about the drive so the formatter can format it. [Figure 2-36](#) shows an example of formatting an unknown hard disk drive and also explains the data needed to format the unknown disk drive.

**CAUTION:** *Formatting destroys all user data on the disk or diskette.*

To run the formatter, enter TEST 70 then enter the drive number when the formatter asks, VSfmt\_QUE\_unitno (0-2) ? \_ \_ . Enter a 0 for the hard disk drive in the system box, enter 1 for the hard disk drive in the expansion box, and enter 2 for a diskette in the floppy drive. If you entered a 0 or 1 for a hard disk, follow [Figure 2-34](#). If you entered 2 for a floppy diskette, follow [Figure 2-35](#).

## Figure 2-34: Example of Formatting a Hard Disk Drive

```
>>> TEST 70

                                KA410-A  RDRXfmt

VSfmt_QUE_unitno (0-2) ?  0          <--- Enter drive number.
VSfmt_STS_Size ..... RD32          <--- RD32 is DUA0.
VSfmt_QUE_SerNbr (0~999999999) ? 361 <--- Enter a number.
VSfmt_QUE_RUsure (DUA0 1/0) ? 1     <--- Enter a 1 for yes,
                                        0 for no.
VSfmt_STS_RdMbb .....OK            <--- Manufacturer's bad
                                        block located.
VSfmt_STS_FMTing .....OK           <--- Disk formatted OK.
VSfmt_STS_ChkPss .....OK           <--- Check pass is OK.
VSfmt_STS_BBRvec := 7               <--- Number of bad blocks
                                        revectored.
VSfmt_RES_Succ                       <--- Disk is formatted
                                        successfully.

>>>
```

## Figure 2-35: Example of Formatting an RX33 Floppy Diskette

>>> TEST 70

KA410-A RDRXfmt

```
VSfmt_QUE_unitno (0-2) ? 2      <--- Enter drive number.
VSfmt_QUE_RXmedtyp
( 1=RX33 ) ? 1                  <--- Enter a 1 if RX33
                                diskette media.
VSfmt_QUE_RUsure (DUA2 1/0) ? 1 <--- Enter a 1 for yes,
                                0 for no.
VSfmt_STS_FMTing .....OK       <--- Diskette formatted OK.
VSfmt.STS.CkRXfmt ..... OK     <--- RX33 format checked OK.
VSfmt_RES_Succ                  <--- Diskette is formatted
                                successfully.

>>>
```

## Figure 2-36: Example of Formatting an Unknown Hard Disk Drive

```
>>> TEST 70

                                KA410-A  RDRXfmt

VSfmt_QUE_unitno (0-2) ? 0          <--- Enter drive number.
VSfmt_STS_Siz ..... ?????         <--- Unknown disk drive.
VSfmt_STS_EntUIB   <--- Formatter needs disk specifics.
xbnsiz := 54       <--- Enter number of transfer blocks.
dbnsiz := 48       <--- Enter number of diagnostic blocks.
lbnsiz := 83236    <--- Enter number of logical blocks.
rbnsiz := 200      <--- Enter number of replacement blocks.
surpun := 6        <--- Enter number of surfaces per unit.
cylpun := 820      <--- Enter number of cylinders per unit.
wrtprc := 820      <--- Enter the write precompensation
                        cylinder.
rctsiz := 4        <--- Enter size of revectoring control
                        table (RCT).
rctnbr := 8        <--- Enter number of copies of RCT.
secitl := 1        <--- Enter the sector interleave.
stsskw := 2        <--- Enter the surface to surface skew.
ctcskw := 9        <--- Enter the cylinder to cylinder skew.
mediai := 627327008 <--- Enter the media MSCP ID.
MSfmt_QUE_SerNbr (0-999999999) ? 361 <--- Enter serial number.
VSfmt_QUE_RUsure (DUA0 1/0) ? 1    <--- Enter 1 for yes,
                                0 for no.
VSfmt_STS_RdMbb .....OK           <--- Manufacturer's bad
                                block located.
VSfmt_STS_FMTing .....OK          <--- Disk formatted OK.
VSfmt_STS_ChkPss .....OK          <--- Check pass is OK.
VSfmt_STS_BBRvec := 2              <--- Number of bad blocks
                                revectorred.
VSfmt_RES_Succ                    <--- Disk is formatted
                                successfully.

>>>
```

### 2.5.9.1 Disk Formatter Messages

All messages for the formatter start with VSfmt\_. The second segment of the message indicates the type of message; STS\_ for a Status message, QUE\_ for a question that waits for a response, and RES\_ for an indication of a resultant message. [Table 2-17](#) lists all the formatter messages and gives an explanation for each.

**Table 2-17: Disk Formatter Messages**

Formatter Message	Explanation
VSfmt_STS_ChkPss	A check pass is being done on the disk.
VSfmt_STS_CkRXfmt	The RX33 diskette format is being checked.
VSfmt_STS_EntUIB	The formatter has sized an unknown disk and will prompt you to input information about the disk.
VSfmt_STS_FMTing	The disk is being formatted.
VSfmt_STS_RdMbb	The manufacturer's bad block is being located.
VSfmt_STS_RXfmt	The RX33 diskette is being formatted.
VSfmt_STS_Siz	The hard disk selected is being sized.
VSfmt_QUE_RUsure (DUA# 1/0) ?	The formatter uses this question as a safety check. If you want to format the disk or diskette that is indicated by the #, enter 1 for yes. Otherwise, enter any character other than 1 to abort the formatter.
VSfmt_QUE_SerNbr (0-999999999) ?	Enter a number for the hard disk you are formatting. The number can be any number from 0 to 999999999. This number should be the serial number of the drive, but does not have to be. You can enter a 0 for DUA0 and a 1 for DUA1, but any number will do.
VSfmt_QUE_unitno (0-2) ?	Enter the drive that needs formatting. Enter 0 for DUA0, 1 for DUA1, and 2 for DUA2. Any other character aborts the formatter.
VSfmt_RES_Succ	The disk has been successfully formatted.
VSfmt_RES_Abtd	The RDRX formatter has been aborted.
VSfmt_RES_ERR #	The formatter has been stopped because of the error code indicated by the #. <a href="#">Table 2-18</a> lists the error codes.

**Table 2-18: Error Codes for the Disk Formatter**

Code	Description
1	Illegal unit number entered.
2	Error occurred during the RD autosizer. Either a disk is not a Digital disk or the disk is bad.
3	Error occurred during formatting.
4	Error occurred during the hard disk check pass.
5	Error occurred during the floppy disk check pass.
6	No diskette loaded in the floppy drive or the diskette is not RX33 media.

## 2.5.10 Mass Storage Disk Verifier

This utility verifies the hard disk formats. It does not verify the diskette formats nor does it destroy data on the disks. The command to start the verifier is TEST 71. [Figure 2-37](#) shows an example of running the formatter on DUA1.

To run the verifier, enter TEST 71, then enter the drive number when the verifier asks, VSmsv\_QUE\_unitno (0-1) ? \_ \_ . Enter a 0 for the hard disk drive in the system box or enter 1 for the hard disk drive in the expansion box.

### Figure 2-37: Example of Running the Disk Verifier on DUA1

```
>>> TEST 71

                                KA410-A RDver

VSmsv_QUE_unitno (0-1) ? 1      <--- Enter drive number.
VSmsv_STS_Siz .. RD53           <--- Drive being sized
VSmsv_QUE_RUsure (DUA1 1/0) ? 1 <--- Enter a 1 for yes,
                                0 for no.
VSmsv_STS_RDing .....OK        <--- Read pass finished OK.
VSmsv_8TS_OBBcnt = 16          <--- Old bad block count.
VSmsv_STS_NBBcnt = 0           <--- New bad block count.
VSmsv_RES_Succ                  <--- Disk verified
                                successfully.

>>>
```

#### 2.5.10.1 Disk Verifier Messages

All messages for the verifier start with VSmsv\_. The second segment of the message indicates the type of message. STS\_ for a status message, QUE\_ for a question that waits for a response, and RES\_ for an indication of a resultant message. [Table 2-19](#) lists all the verifier messages and gives an explanation for each.

**Table 2-19: Disk Verifier Messages**

Verifier Message	Explanation
VSmsv_STS_NBBcnt	The verifier lists the new bad block count since the last time the disk was formatted.
VSmsv_STS_NBBpo3	The verifier lists the new bad block locations if any new bad blocks are found. It lists the cylinder number, surface, and the sector.
VSmsv_STS_OBBcnt	The verifier lists the old bad block count.
VSmsv_STS_RDing	The verifier is reading the disk.
VSmsv_STS_Siz	The hard disk selected is being sized.
VSmsv_QUE_RUsure (DUA# 1/0) ?	The verifier uses this question as a safety check. If you want to verify the disk indicated by the #, enter 1 for yes. Otherwise, enter any character other than 1 to abort the verifier.
VSmsv_QUE_unitno (0-1) ?	Enter the drive that you are verifying. Enter 0 for DUA0 or a 1 for DUA1. Any other character aborts the verifier.
VSmsv_RES_Succ	The disk has been successfully verified.
VSmsv_RES_Abtd	The RD verifier has been aborted.
VSmsv_RES_ERR #	The verifier has been stopped because of the error code indicated by the #. <a href="#">Table 2-20</a> lists the error codes.

**Table 2-20: Error Codes for the Disk Verifier**

Code	Description
1	Illegal unit number entered.
2	Error occurred during the RD autosizer. The disk may not be formatted.
3	Error reading the revectorized block control table (RCT)

## 2.5.11 Special Diagnostic Key for Field Service System Exerciser

The removable media in the maintenance kit contains a special diagnostic code on it that allows the system exerciser to write on this media when running in field service mode. Without this special coding, such as on normal customer media, the system exerciser does not do write testing on the removable media devices. This safety feature prevents accidentally destroying the customers programed floppy diskettes or TK50 COMPACTapes.

There are two Utilities that create these special-keys for the floppy diskette and TK50 COMPACTapes. TEST 72 creates a special-key on the floppy diskette and TEST 73 creates a special-key on the TK50 COMPACTape. The diskette and COMPACTape in the maintenance kit must be initialized with these special diagnostic keys before they can be used. The COMPACTape must be initialized

every time you use it with the field service system exerciser, because the special diagnostic key on the COMPACTape is destroyed once the exerciser recognizes the key. The special diagnostic key on the floppy diskette is not destroyed when it is used. Figure 2-38 shows a successful example of creating a special-key floppy diskette. Figure 2-39 shows a successful example of creating a special-key COMPACTape cartridge. If any errors occur while running TEST 72 or TEST 73, make sure the drive is on-line and operating properly and run the special-key command again. Also, make sure the COMPACTape is not write protected.

### Figure 2-38: Example of Creating the Special Key on a Floppy Diskette

```
>>> TEST 72

                KA410-A RXmker

VSfmk_QUE_MEDtyp (0=RX50) (1=RX33) ? 0 <--- Enter media type.
VSfmk_QUE_RUsure (DUA2 1/0) ? 1      <--- Enter 1 for yes,
                                         0 for no.
VSfmk_RES_SUCC                          <--- Keyed successfully.

>>>
```

### Figure 2-39: Example of Creating the Special Key on a COMPACTape Cartridge

```
>>> TEST 73

                KA410-A TPmker

VStmk_QUE_id (1,2,3,4,5,6,7) ? 1 <--- Enter ID address of drive.
VStmk_QUE_RUsure (1/0) ? 1      <--- Enter 1 for yes, 0 for no.
VStmk ..... OK                  <--- Keyed successfully.

>>>
```

## 2.5.12 ThinWire Network Loop Testing Utility

This utility enables a ThinWire Ethernet network loop test or system ID procedure to verify correct operation of the ThinWire Ethernet port. It sets up the system to loopback Thinwire Ethernet data packets from another node which uses troubleshooting software such as NIE, Ethernim, UETP, or NCP loop testing. This troubleshooting software does Ethernet loop testing at various levels:

firmware/hardware loop testing, protocol loop testing, operating system loop testing, and application loop testing. The level this utility works on is the firmware/hardware loop testing. You use this utility if booting over the network fails or if other levels of loopback testing fail. The other levels of loopback testing do not need to use this utility.

To run this utility, halt the system and enter console mode. Once in console mode, enter TEST 90 to start the utility. The screen blanks then displays `_E_net$_util` followed by the Ethernet address of the system. Now the system is ready to respond to the network loopback commands issued from any other node on the network (typically the host system). Once TEST 90 is entered, nothing more can be done on this system since this system is now acting like a loopback connector. All loopback commands must be sent from another node on the network.

When a loopback data packet is received from another node, the system checks for errors and extracts the Ethernet address of the next node that this packet must be sent to. The Ethernet address of the next node that this system is sending the loopback packet to is displayed on the screen. Most likely, the Ethernet address displayed on the screen will be the node that sent the packet, but some troubleshooting software have the capability to do three or more node loopback testing. Once all loopback testing is complete, enter a carriage return to get a report on the status of the loopback testing. Enter a `[CTRL/C]` to exit TEST 90 and return to the console prompt. [Figure 2-40](#) shows an example of the report. [Table 2-21](#) lists the definitions of each item in the report.

**Figure 2-40: Example of ThinWire Ethernet Loop Testing Using TEST 90**

```
>>> TEST 90

_E_net$_util
ID 08-00-2B-02-CF-A4      <--- Ethernet address of this node

08-00-2B-03-CF-A8      <--- Ethernet address of next node

<RETURN>                <--- Enter a carriage return

req$_num      - 0      sysid$_cnt      - 0
tx$_cnt       - 0
rx$_cnt       - 0
mxcst$_cnt    - 0      jnk$_pkts       - 0
r_err         - 0
r_fram        - 0      r_oflo          - 0
r_crc         - 0      r_buff          - 0
t_err         - 0      t_more          - 0
t_one         - 0      t_def           - 0
t_buff        - 0      t_uflo          - 0
t_lcol        - 0      t_lcar          - 0
t_rtry        - 0      hng$_tx         - 0
s_err         - 0
s_babl        - 0      s_cerr          - 0
s_miss        - 0      s_raerr         - 0
```

**Table 2-21: ThinWire Ethernet Loopback Test Report Definitions**

Item	Definition
req\$_num	System ID request response sent
sysid\$_cnt	Unsolicited system ID's sent
tx\$_cnt	Packets transmitted
rx\$_cnt	Packets received
mxkst\$_cnt	Multicast or broadcast packets received
jnk\$_pkts	Packets received with bad format
r_err	Total receive errors detected by lance
r_fram	Receive framing error
r_oflo	Receive FIFO overflow error
r_crc	Receive crc error
r_buff	Receive buffer in chain not available error
t_err	Total transmit errors detected by lance
t_more	Transmits with more than one collision
t_one	Transmits with one collision
t_def	Transmits deferred
t_buff	Transmit buffer not available error
t_uflo	Transmit FIFO underflow error
t_lcol	Transmits with late collision error
t_lcar	Transmit loss of carrier error
t_rtry	Transmit maximum retry error
hng\$_tx	Transmit failed to complete error
s_err	Total errors reported in CSR0 of lance
s_babl	Babble error
s_cerr	Collision check (heartbeat) error
s_miss	Missed packet, no buffer available
s_merr	DMA memory access or memory parity error

# Chapter 3

## FRU REMOVAL AND REPLACEMENT PROCEDURES

### 3.1 Introduction

This chapter describes the removal and replacement procedures for the field replaceable units (FRUs). To use this chapter, find the name of the FRU that needs replacing in Table 3-1 then go to the section listed beside the FRU. Follow the steps in the section to remove the FRU and reverse the procedures to replace the FRU.

**Table 3-1: FRU Section Listings**

FRU	Section	Page
Battery pack	<a href="#">3.10</a>	3-33
DEC423 Converter (MicroVAX 2000 only)	<a href="#">3.15.1</a>	3-53
Expansion adapter	<a href="#">3.16</a>	3-54
Expansion adapter disk interface module	<a href="#">3.16.1</a>	3-56
Hard disk expansion box	<a href="#">3.17.1</a>	3-58
Keyboard (VAXstation 2000 only)	<a href="#">3.13</a>	3-51
Memory module	<a href="#">3.5</a>	3-17
Mouse (VAXstation 2000 only)	<a href="#">3.14</a>	3-52
Network interconnect module	<a href="#">3.6</a>	3-18
Power supply in hard disk expansion box	<a href="#">3.17.1.2</a>	3-66
Power supply in system box	<a href="#">3.11</a>	3-64
Power supply in tape drive expansion box	<a href="#">3.17.2.3</a>	3-79
RD32 disk drive	<a href="#">3.8</a>	3-24
RD32 disk drive device electronics board	<a href="#">3.8.1</a>	3-27

**Table 3-1 (Cont.): FRU Section Listings**

FRU	Section	Page
RD53 disk drive	<a href="#">3.7</a>	3-19
RD53 disk drive device electronics board	<a href="#">3.7.1</a>	3-21
RD53 disk drive in hard disk expansion box	<a href="#">3.17.1.1</a>	3-60
Resistor load board in hard disk expansion box	<a href="#">3.17.1.3</a>	3-70
Resistor load board in system box	<a href="#">3.9</a>	3-31
Resistor load board in tape drive expansion box	<a href="#">3.17.2.4</a>	3-81
RX33 floppy disk drive	<a href="#">3.8</a>	3-24
System module	<a href="#">3.4</a>	3-13
Tablet (VAXstation 2000 only)	<a href="#">3.14</a>	3-52
Tape drive expansion box	<a href="#">3.17.2</a>	3-72
Terminal disconnection from MicroVAX 2000	<a href="#">3.15</a>	3-53
TK50 tape drive in tape drive expansion box	<a href="#">3.17.2.2</a>	3-76
TZK50 Controller board in tape drive expansion box	<a href="#">3.17.2.1</a>	3-73
VR260 deflection board	<a href="#">3.12.2</a>	3-39
VR260 monochrome monitor	<a href="#">3.12</a>	3-35
VR260 power LED	<a href="#">3.12.7</a>	3-50
VR260 rear bulkhead assembly	<a href="#">3.12.3</a>	3-42
VR260 transformer assembly	<a href="#">3.12.5</a>	3-45
VR260 video board	<a href="#">3.12.4</a>	3-44
VR260 tube/yoke/bezel assembly	<a href="#">3.12.6</a>	3-47

Figure 3-1 shows the locations of the FRUs as seen from the front.

### Figure 3-1: FRU Locations

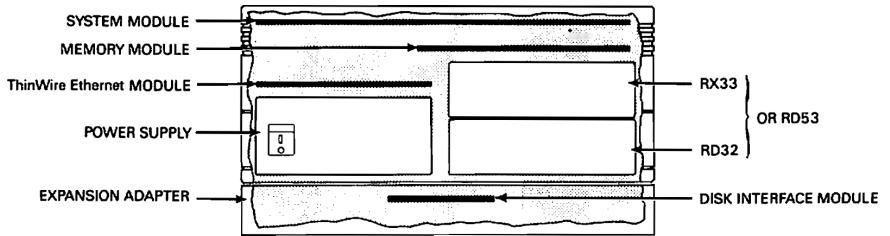

VAXstation 2000 AND MicroVAX 2000 SYSTEM BOX

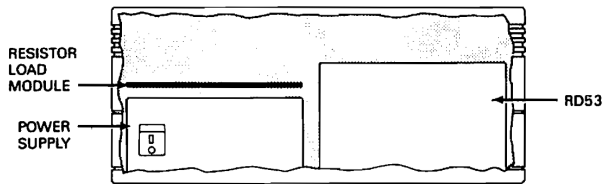
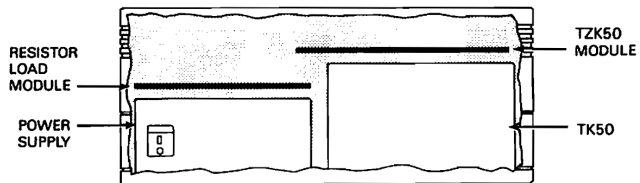

VAXstation 2000 AND MicroVAX 2000 EXPANSION BOXES

MR-1186-1276  
MA-0133-87

## 3.2 Shield Removal

1. Turn the system power switch off and disconnect all cables from the rear of the system box.
2. If the system is a MicroVAX 2000, remove the DEC423 converter from the rear of the system box.
3. If the expansion adapter is installed, then remove the two screws shown in [Figure 3-2](#) on the bottom of the expansion adapter to access the four screws securing the system box cover.

**Figure 3-2: Expansion Adapter Cover Screw Locations**

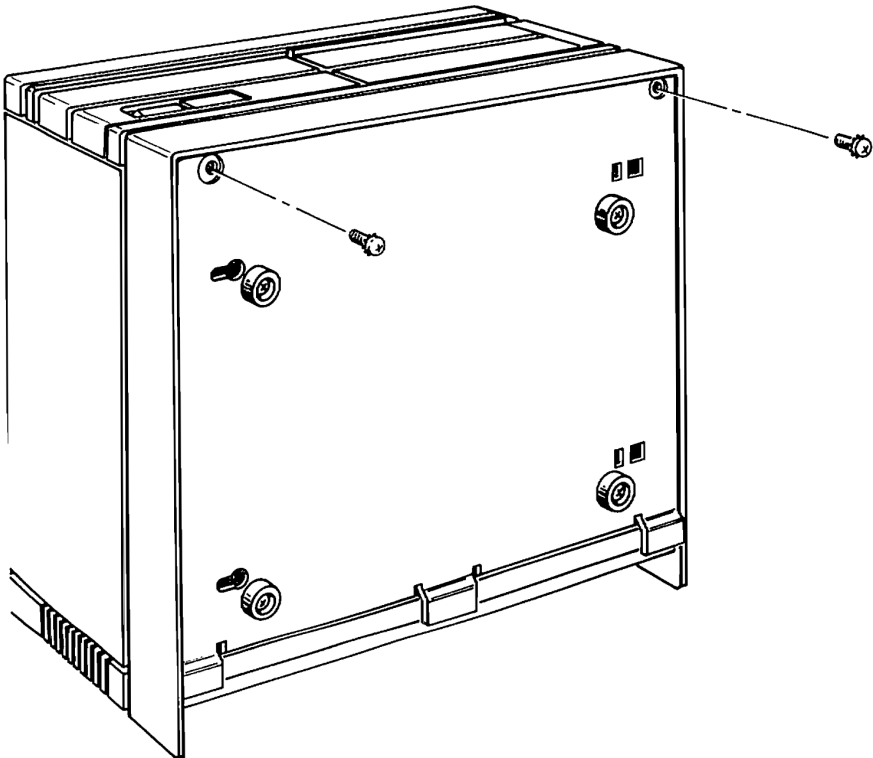

MR-1186-1276  
MA-0069-B7

4. Remove the four system box cover screws shown in [Figure 3-3](#).

**Figure 3-3: System Box Cover Screw Locations**

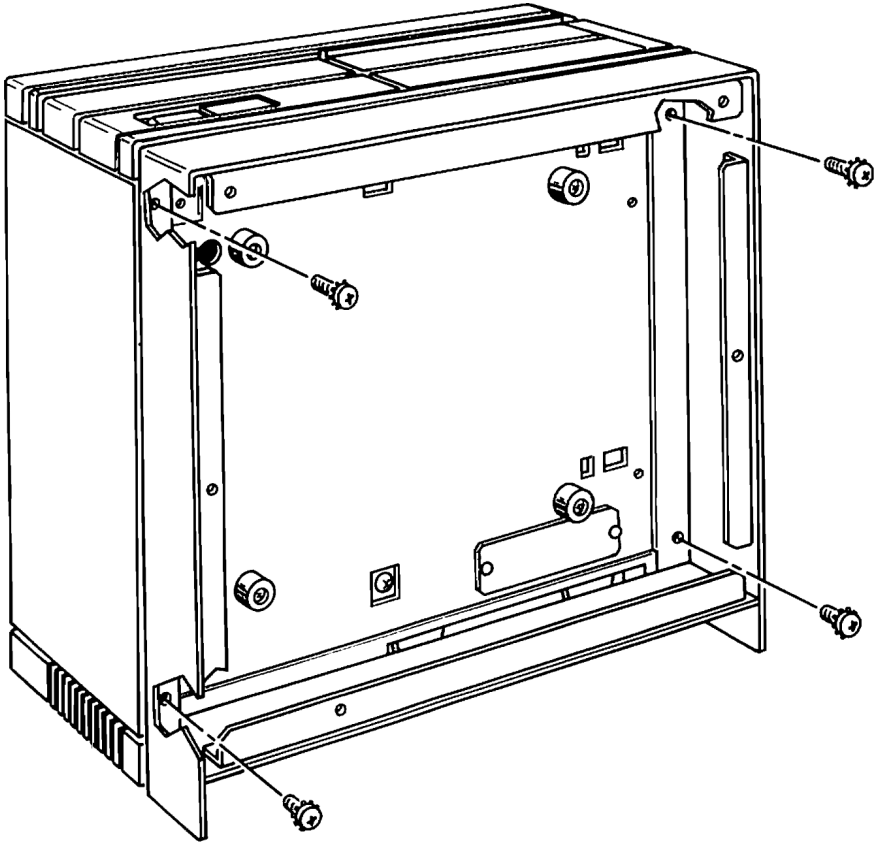

MR-1186-1277  
MA-0070-87

5. Slide the cover off the system box as shown in [Figure 3-4](#).

**Figure 3-4: System Box Cover Removal**

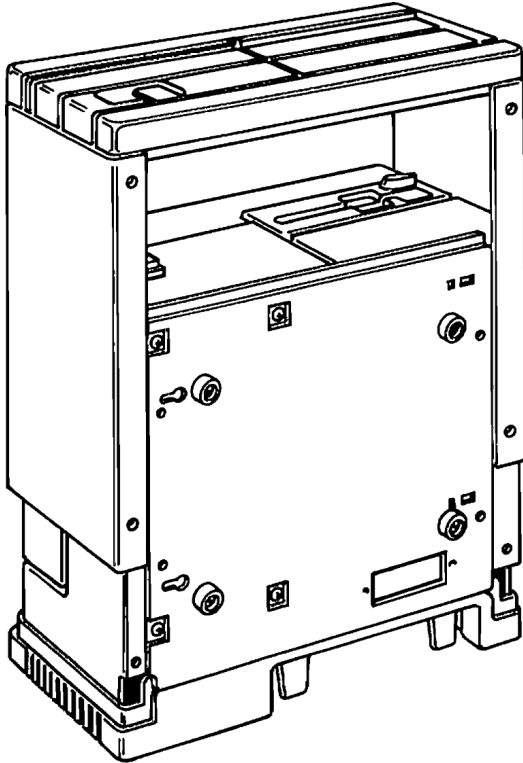

MR-1188-1278  
MA-0071-B7

- Put the system on its feet and remove the five screws shown in [Figure 3-5](#) from the shield.

**Figure 3-5: Shield Screw Locations**

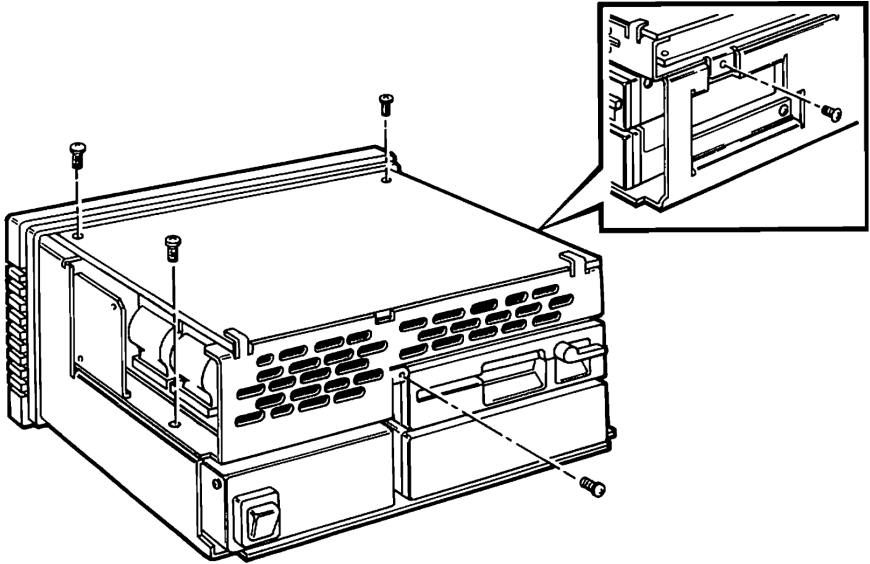

MR-1188-1279  
MA-0072-07

7. Lift the shield as shown in [Figure 3-6](#) and rest it on the rear of the system.

**Figure 3-6: Removing the Shield from the Main Chassis**

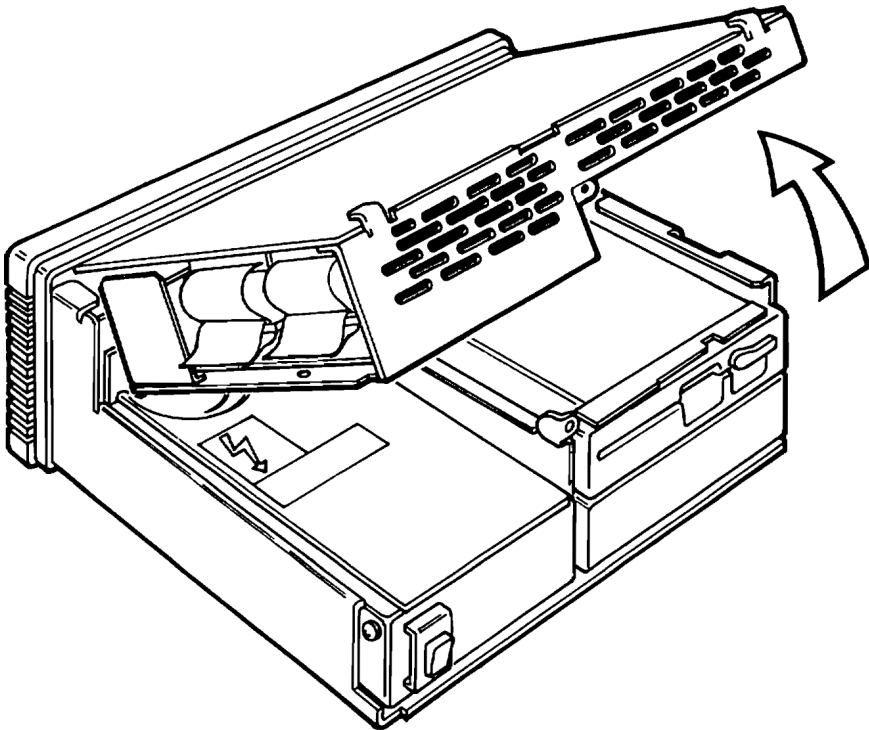

MR-1186-1280  
MA-0073-87

8. Hold the shield with one hand and disconnect the power cable and the drive interconnect cable(s) from the shield with the other hand. Refer to [Figure 3-7](#).

**Figure 3-7: Disconnecting the Cables from the Shield**

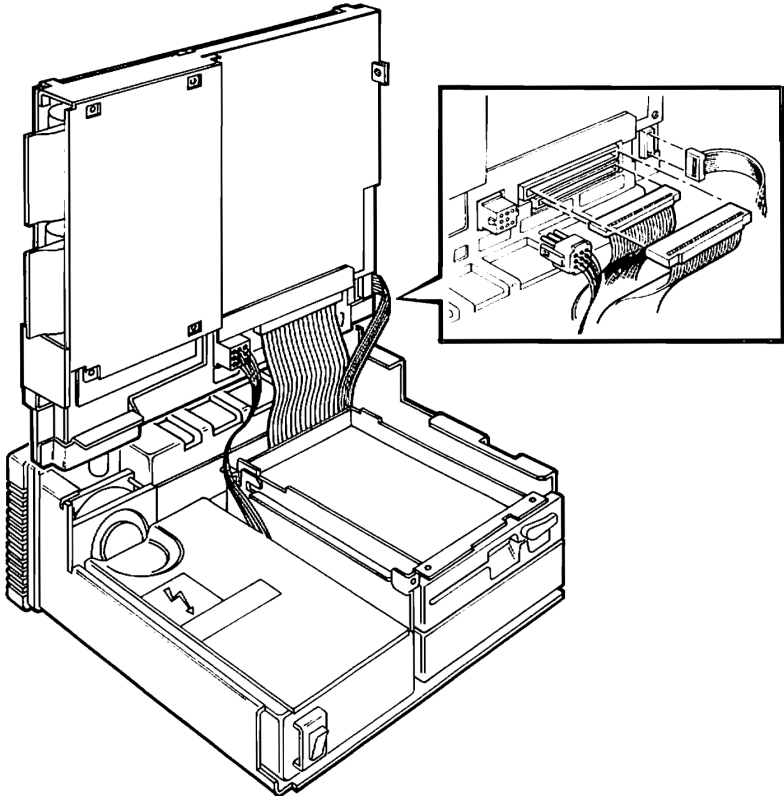

WR1166-1281  
MA-0274-67

9. Lift the shield off the main chassis.
10. Return to the FRU removal instructions that sent you to this procedure.

### 3.3 System Module Assembly Removal from Shield

1. Remove the two screws shown in [Figure 3-8](#) from the shield.

**Figure 3-8: System Module Assembly Screw Locations on the Shield**

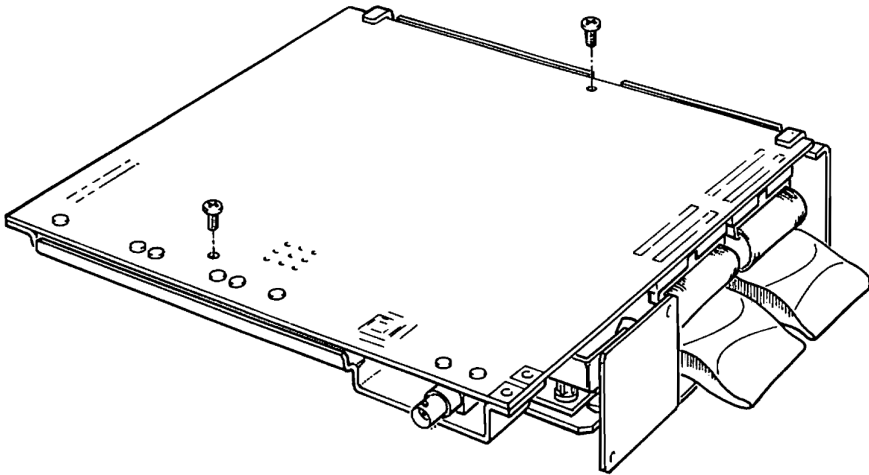

MR-1185-1282  
MA-0075-B7

2. Disconnect the two network interconnect cables shown in [Figure 3-9](#) (if installed).

**Figure 3-9: Network Interconnect Cables**

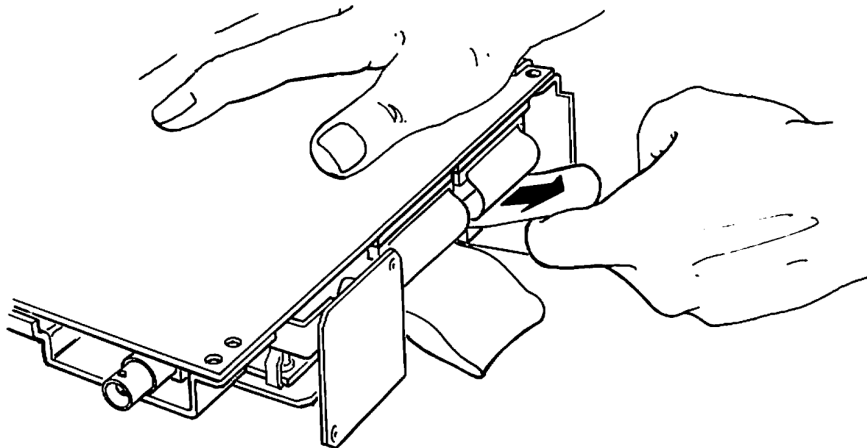

MR-1186-1283  
MA-0076-B7

3. Remove the system module assembly from the shield as shown in [Figure 3-10](#) and lay it down beside the shield.

**CAUTION:** *Disconnection of the battery cable from the system module destroys all NVR memory. Be careful not to disconnect the battery cable from the system module until a procedure specifically instructs you to do so.*

**Figure 3-10: Removing System Module Assembly from Shield**

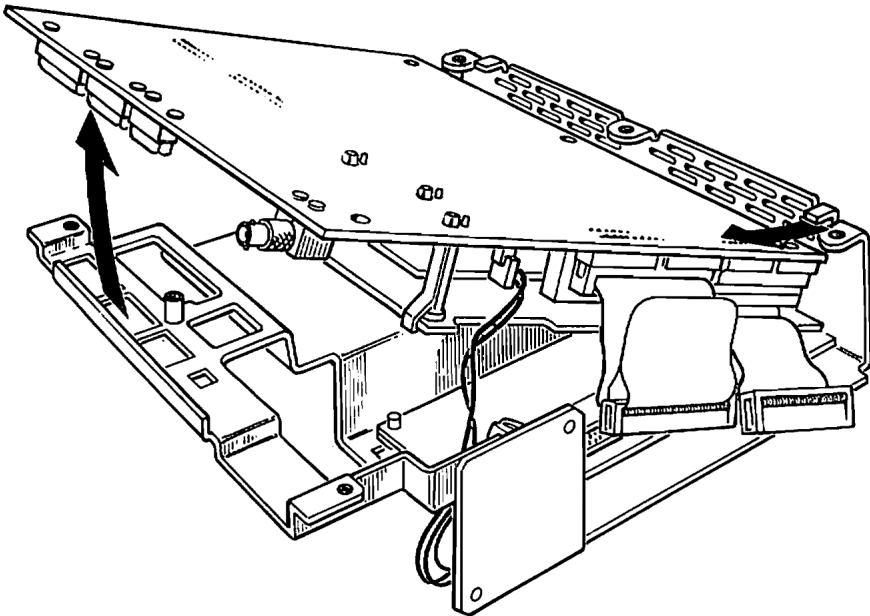

MR-1186-1284  
MA-0077-87

## 3.4 System Module Removal

1. Remove the shield ([Paragraph 3.2](#)).
2. Remove the system module assembly from the shield ([Paragraph 3.3](#)).
3. Disconnect the battery cable from the system module. Refer to [Figure 3-11](#).

**Figure 3-11: Battery Cable Location**

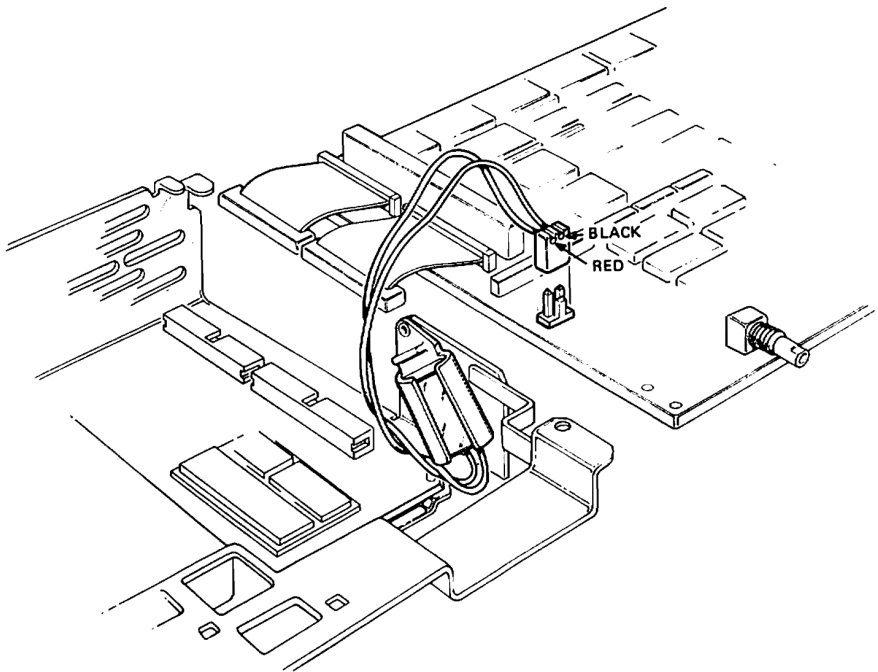

MR-1186-1296  
MA-0078-87

4. Remove the memory module (if installed). Refer to [Figure 3-12](#). Two connectors disconnect as you lift the memory module.

**Figure 3-12: Memory Module Removal**

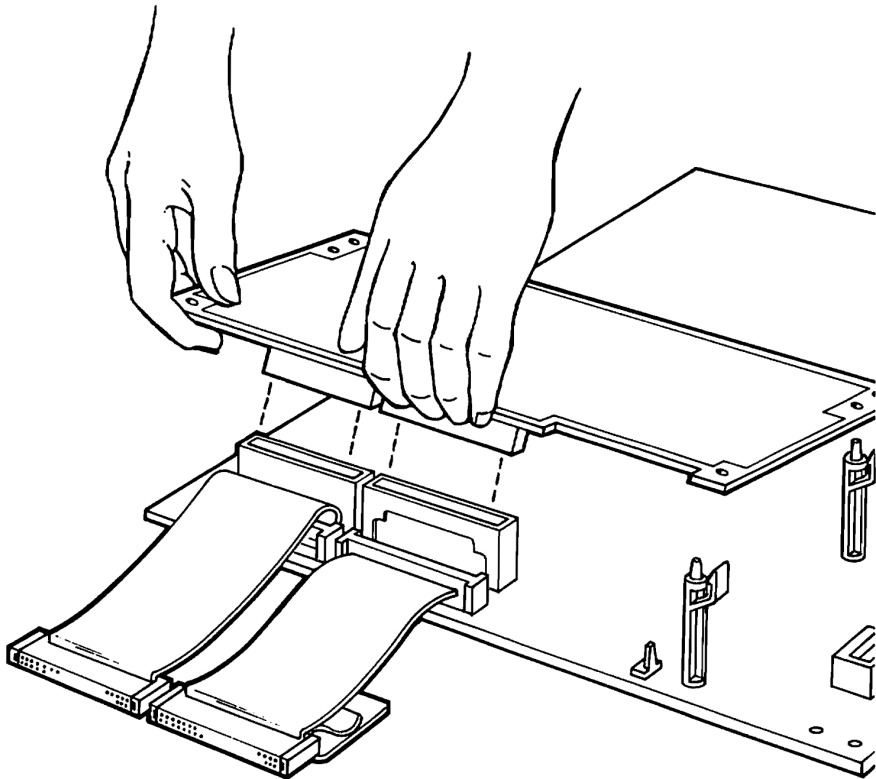

MR-1105-1205  
MA-0079-07

5. Remove the two network interconnect cables from the system module and install them on the new system module.

6. Remove the network ID ROM shown in [Figure 3-13](#) from the system module you are removing and install it on the system module you are installing.

**Figure 3-13: Network ID ROM Location on System Module**

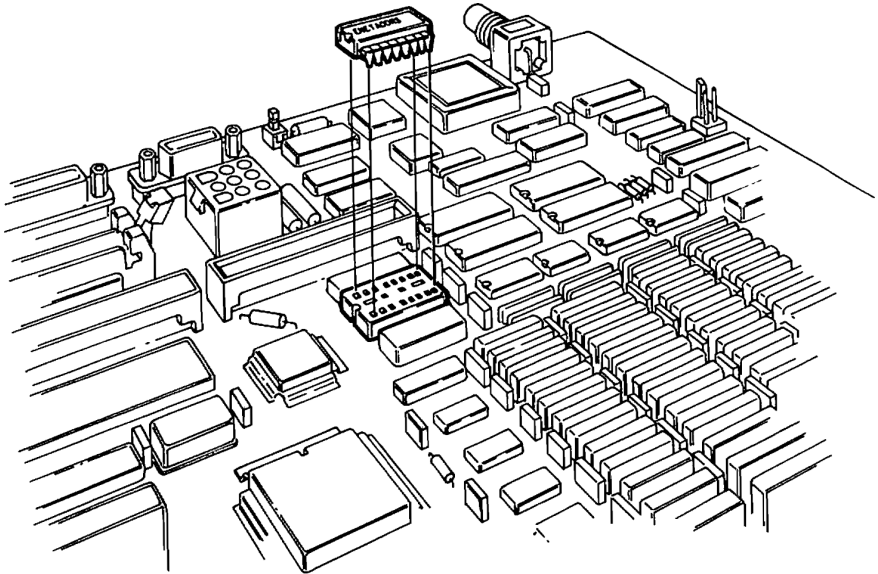

MR-1155-1258  
MA-0080-97

7. You must set the system jumper, shown in [Figure 3-14](#), for either a VAXstation 2000 or a MicroVAX 2000. Both systems use the same system module and this system jumper tells the firmware whether the module is in a VAXstation 2000 or a MicroVAX 2000. Determine which system you are working on and set the jumper accordingly.

**Figure 3-14: VAXstation 2000 and MicroVAX 2000 System Jumper**

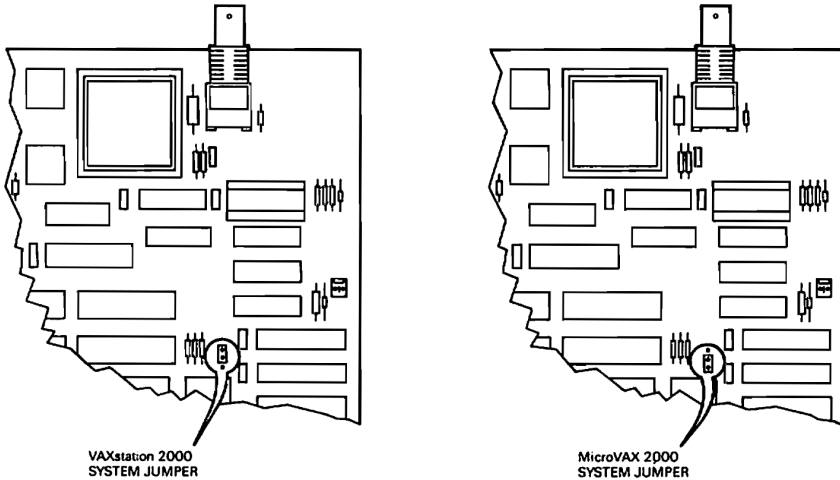

MR-1286-1411  
VA.D061.R7

8. Install the new system module by reversing the above procedures.

## 3.5 Memory Module Removal

1. Remove the shield ([Paragraph 3.2](#))
2. Remove the system module assembly from the shield ([Paragraph 3.3](#))
3. Remove the memory module shown in [Figure 3-15](#). Two connectors disconnect as you lift the module.

**Figure 3-15: Memory Module Removal**

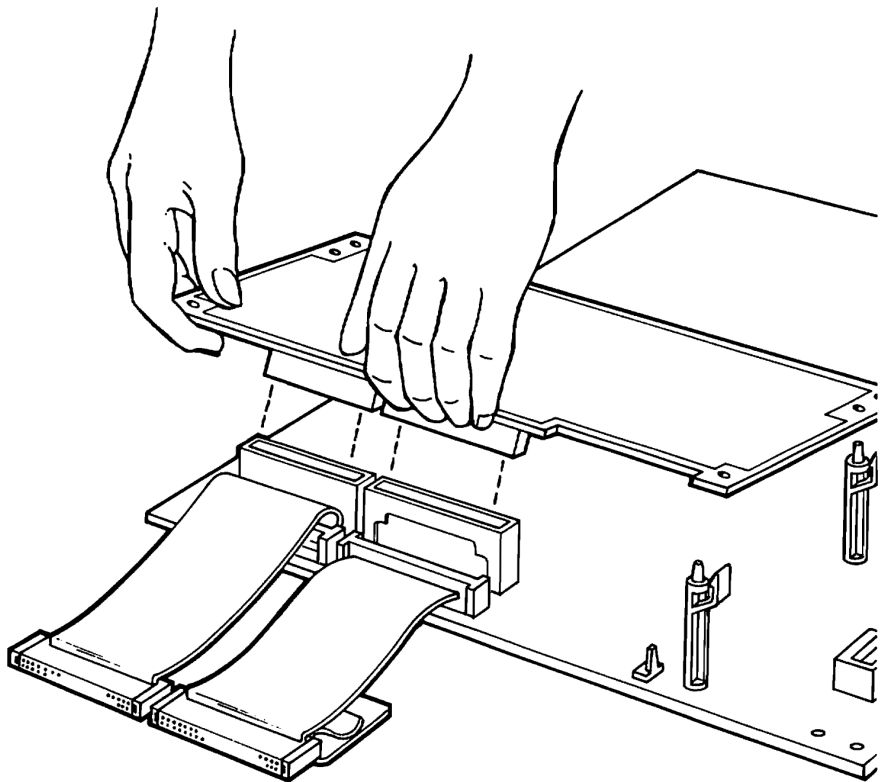

MR-1105-1205  
NA-0079-07

4. Replace the memory module by reversing the above procedures.

## 3.6 Network Interconnect Module Removal

1. Remove the shield ([Paragraph 3.2](#))
2. Remove the system module assembly from the shield ([Paragraph 3.3](#))
3. Remove the network interconnect module from the shield as shown in [Figure 3-16](#).

**Figure 3-16: Network Interconnect Module Removal**

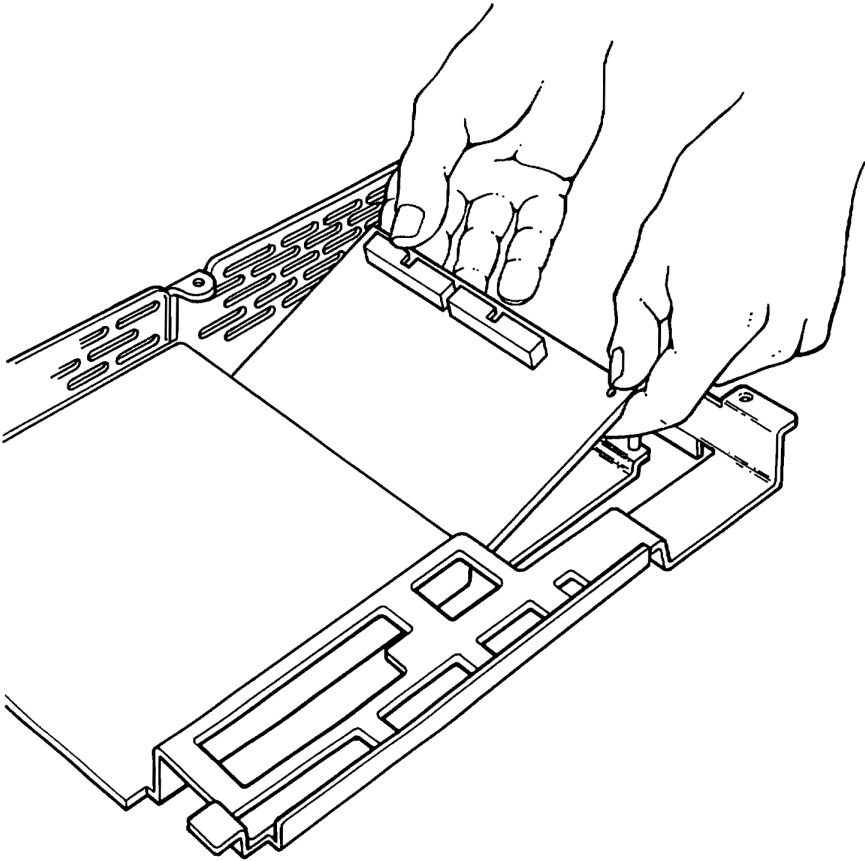

MR-1186-1289  
MA 0082-87

4. Replace the network interconnect module by reversing the above procedures.

## 3.7 RD53 Hard Disk Drive Removal from System Box

1. Remove the shield (Paragraph 3.2)
2. Remove the three screws shown in Figure 3-17 that secure the drive to the chassis.

**Figure 3-17: Hard Disk Screw Locations**

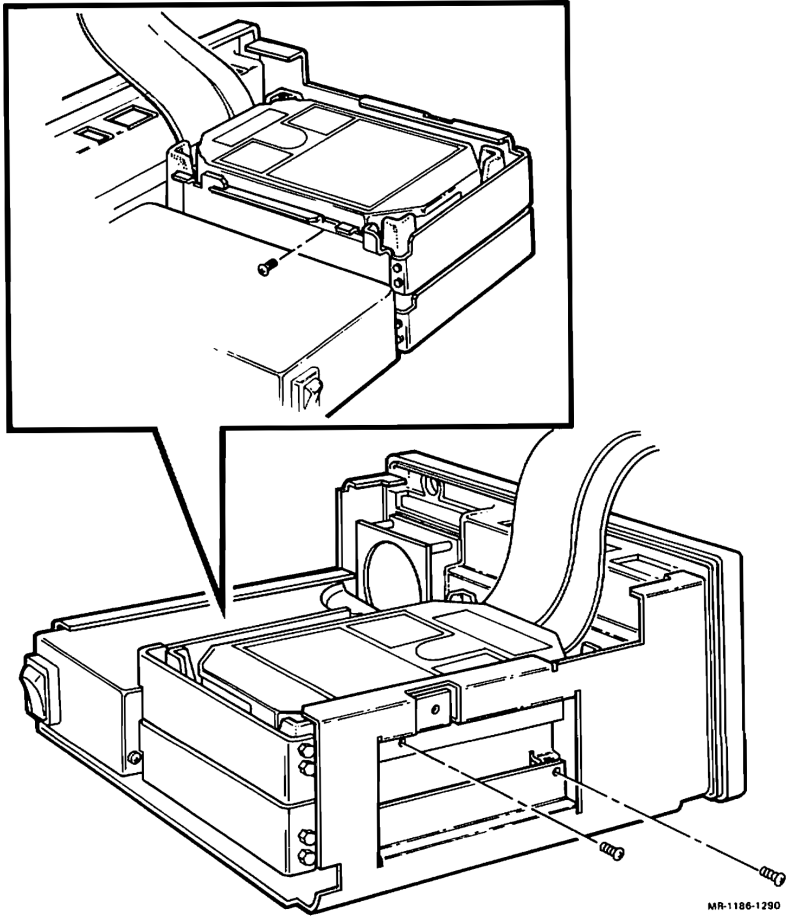

3. Slide the drive out halfway and disconnect the drive interconnect cables and the power cable from the drive as shown in [Figure 3-18](#).

**Figure 3-18: Disconnecting the Hard Disk Drive from System Box**

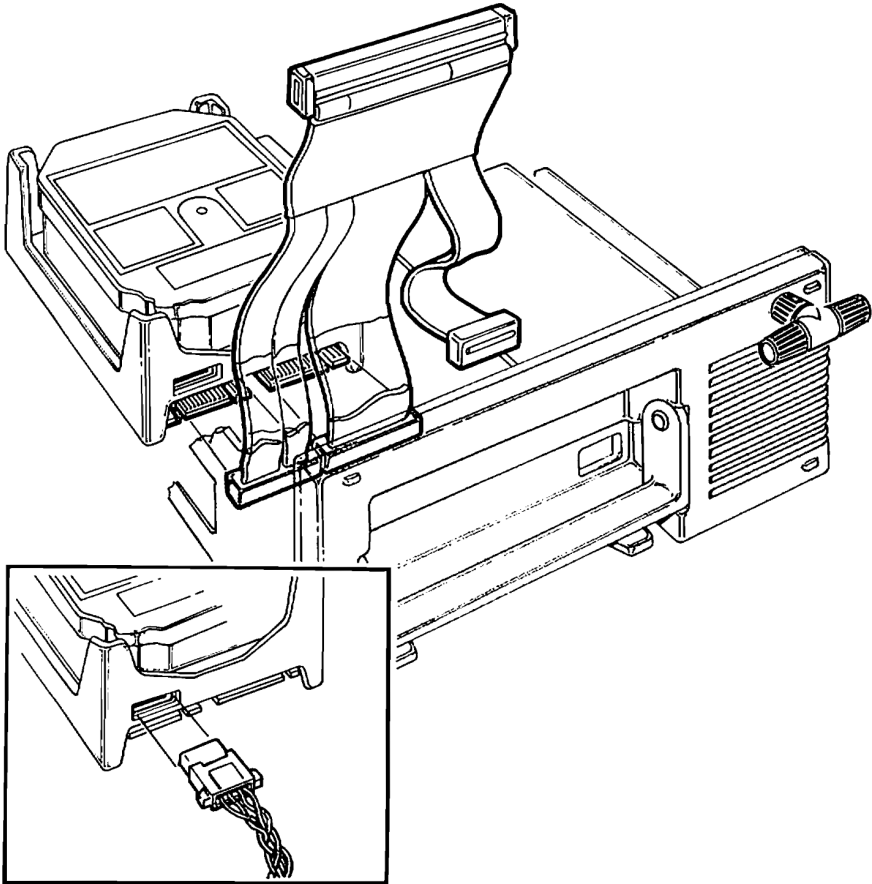

MR-1185-1291  
MA-0125-07

4. Slide the drive out of the chassis.

5. Remove two screws on each side of the drive mounting brackets shown in [Figure 3-19](#). Remove the mounting brackets and front panels from the drive.

**Figure 3-19: Drive Mounting Bracket Screw Locations**

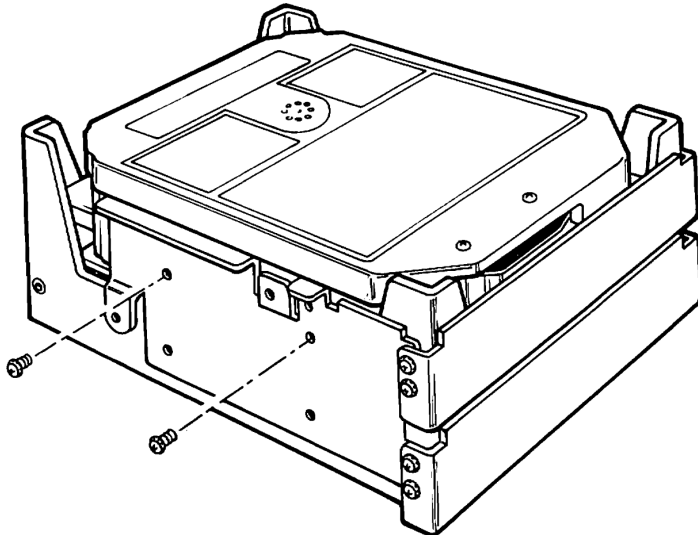

MR-1186-1292  
MA-0084-87

6. If you removed the RD53 because of an error with the drive, go to [Paragraph 3.7.1](#).
7. Reverse the above procedures to replace the drive.

### **3.7.1 RD53 Disk Drive Device Electronics Board Removal**

The RD53 disk drive has an FRU inside it. It is the device electronics board. Always replace the device electronics board on the RD53 before you replace an entire RD53 disk drive.

1. If a skid plate is installed on the drive, remove the four phillips screws securing the skid plate and ground clip to the frame. Remove the plate and set aside.
2. Loosen the two captive screws that hold the device electronics board in place and then disconnect the ground wire.

3. Rotate the board upward as shown in [Figure 3-20](#) (the board pivots in hinged slots at the front of the drive). Be careful not to strain any of the connectors or cables, and tilt the board up and back until it rests against the outer frame.

**CAUTION:** Flexible circuit material is fragile and requires careful handling to avoid damage.

**Figure 3-20: RD53 Device Electronics Board Removal**

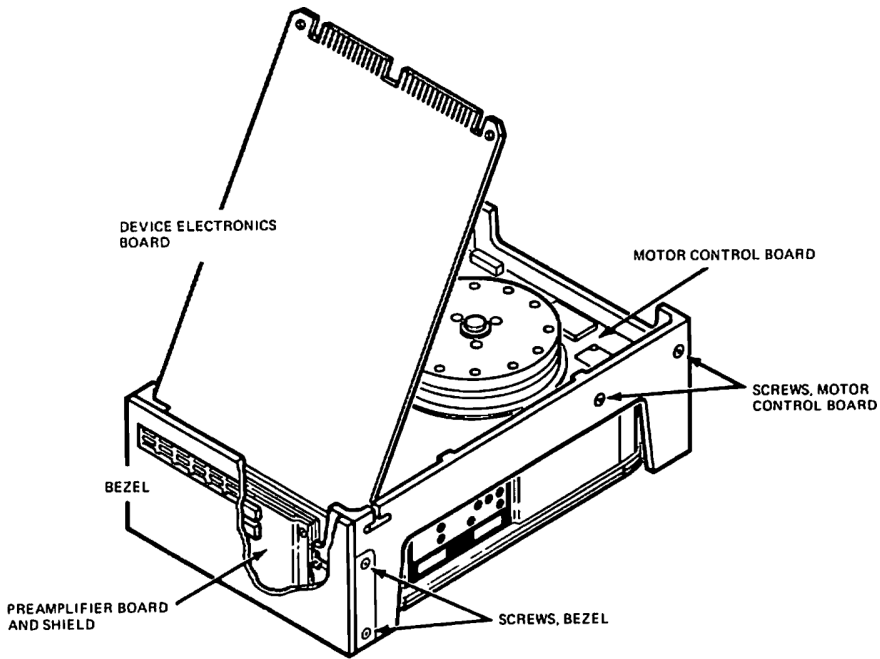

511-R 0134 B5

4. Disconnect the two connectors from under the device electronics board. Both connectors and cables are fragile, handle them with care.
5. Lift the board out of the hinged slots.

6. Position the jumpers and switches on the new board to the same position as the jumpers and switches on the old board you just removed. Refer to [Figure 3-21](#). Also be sure the new board has the resistor terminator pack installed.

**Figure 3-21: RD53 Device Electronics Board Jumper and Switch Locations**

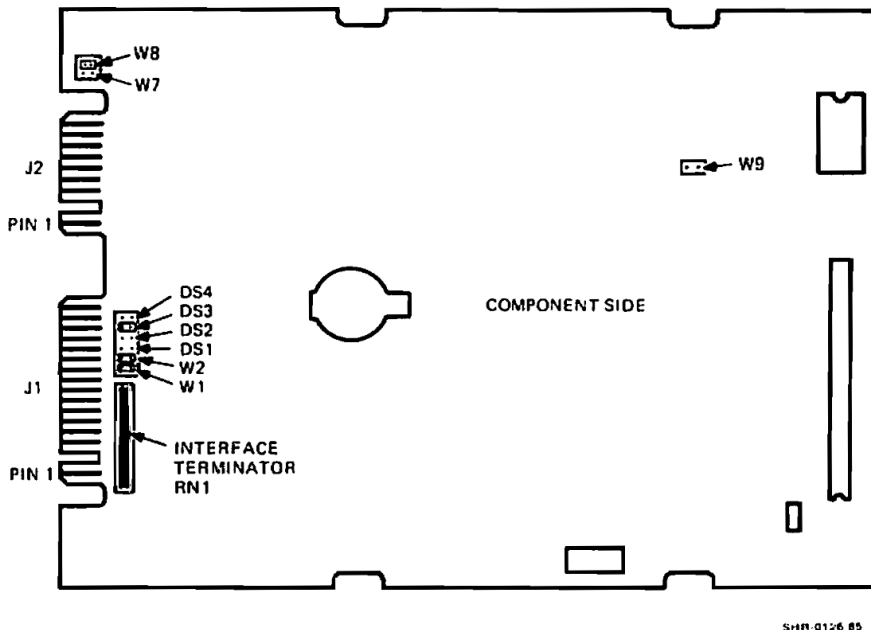

7. Install the replacement device electronics board by reversing the above procedure.

## 3.8 RX33 and RD32 Drive Removal (Half-Height Drives) from the System Box

1. Remove the shield (Paragraph 3.2)
2. Remove the three screws shown in Figure 3-22 that hold the drive(s) to the chassis.

Figure 3-22: Half-Height Drive(s) Screw Locations

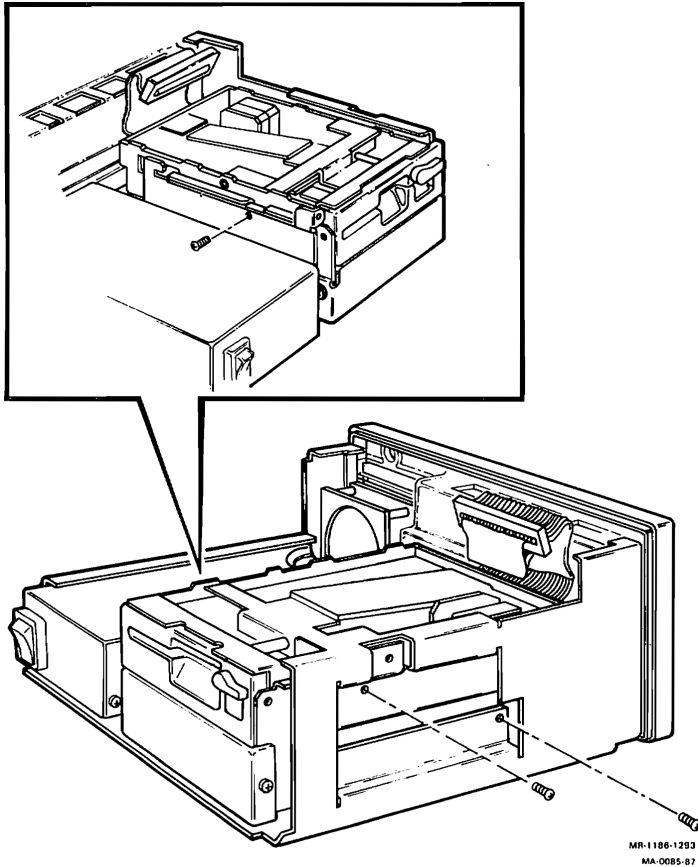

3. Slide the drive(s) out halfway and disconnect the drive interconnect cable(s) and the power cable(s) from the drive(s). Refer to [Figure 3-23](#).

**Figure 3-23: Disconnecting the RX33 and RD32 Half-Height Drives**

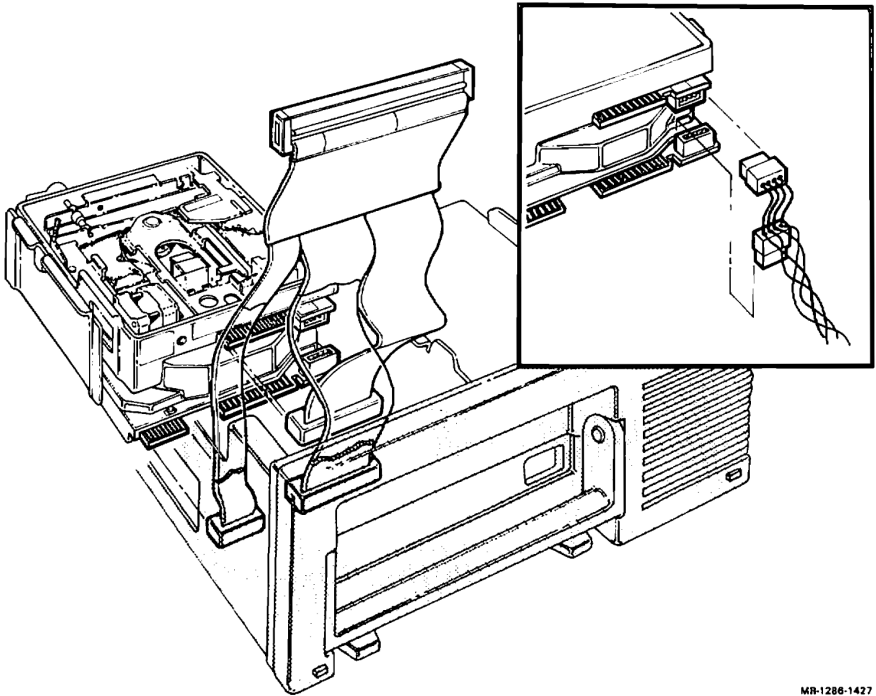

MR-1286-1427  
MA-0086-B7

4. Slide the drive(s) out of the chassis.

5. Remove four screws on each side of the mounting brackets shown in [Figure 3-24](#). Remove the mounting brackets and front panels from the drive(s).

**Figure 3-24: Half-Height Drives Mounting Brackets Removal**

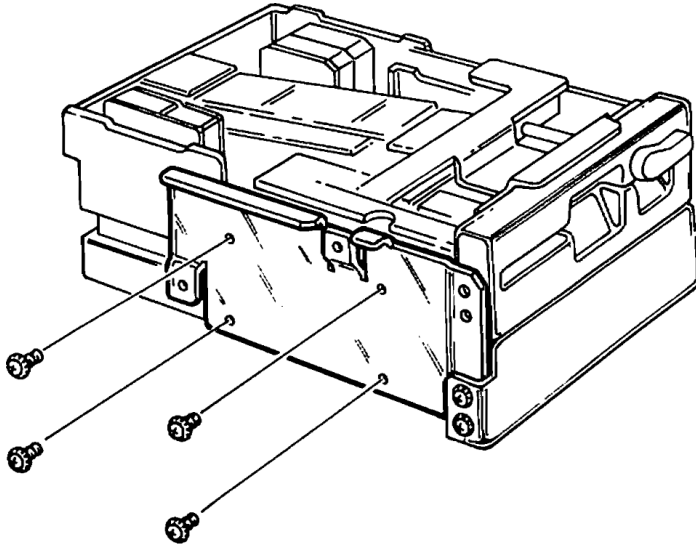

MR-1188-1294  
MA-0087-87

6. If you are replacing the RX33 floppy drive, install the new RX33 by reversing the above procedures.
7. If you removed the RD32 because of an error with the drive, go to [Paragraph 3.8.1](#) below. Then reverse the above procedure to reinstall the drive.

### 3.8.1 RD32 Disk Drive Device Electronics Board Removal

The RD32 disk drive has an FRU inside it. It is the device electronics board. Always replace the device electronics board on the RD32 before you replace an entire RD32 disk drive.

**CAUTION:** Do not remove any of the screws that secure the cover (cover/filter assembly) to the base casting. Removing any of the screws violates the clean area.

1. Remove the three flat head screws shown in [Figure 3-25](#) that hold the device electronics board in place under the drive unit. Be sure to locate the one screw with the nylon washer next to the drive motor when replacing the board.

**Figure 3-25: RD32 Device Electronics Board Screw Locations**

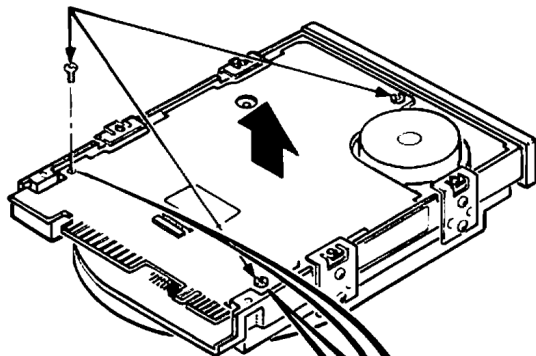

**CAUTION:** MAKE SURE YOU REMOVE THE DEVICE PRINTED CIRCUIT BOARD WASHER. A WASHER ACCIDENTALLY DROPPED IN THE DISK DRIVE COULD DAMAGE THE DRIVE.

**NOTE:** IF IT IS NECESSARY TO REPLACE ANY OF THE DEVICE ELECTRONICS BOARD SCREWS, THESE MOUNTING SCREWS MUST NOT EXTEND MORE THAN 0.64 CM (0.25 IN) INSIDE THE DRIVE.

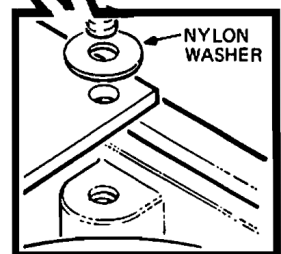

LJ 0694  
SHR-0296-86

2. Disconnect the cable from J4 (middle of board) as shown in [Figure 3-26](#). The J4 connector is not keyed and can be reconnected incorrectly. Make sure the violet and yellow wire in the connector is located near the LED and the orange and blue wires are located toward the outer edge of the board when reconnecting J4.

**Figure 3-26: Disconnecting J4 from RD32 Device Electronics Board**

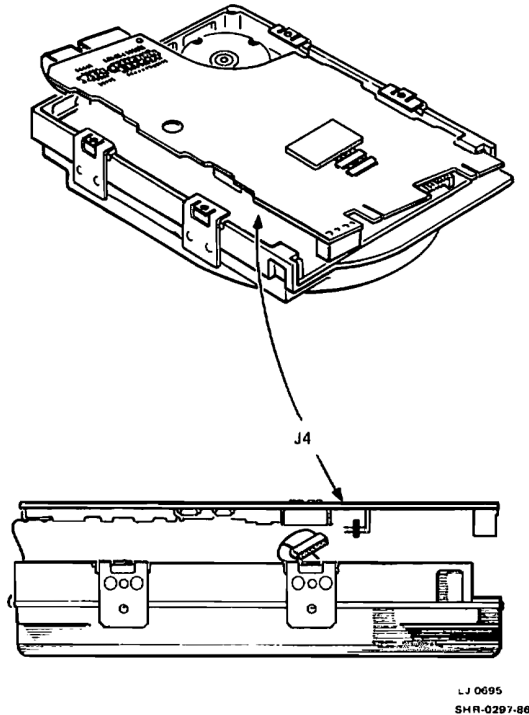

3. Stand the board up. Be careful not to strain any of the connectors or cables, and tilt the board over center until it rests against the outer frame.

**CAUTION:** *Flexible circuit material is fragile and requires careful handling to avoid damage.*

4. Disconnect the cables from J6 and J5 as shown in [Figure 3-27](#) from the device electronics board. Both connectors and cables are fragile – handle them with care.

**Figure 3-27: Disconnecting J5 and J6 from RD32 Device Electronics Board**

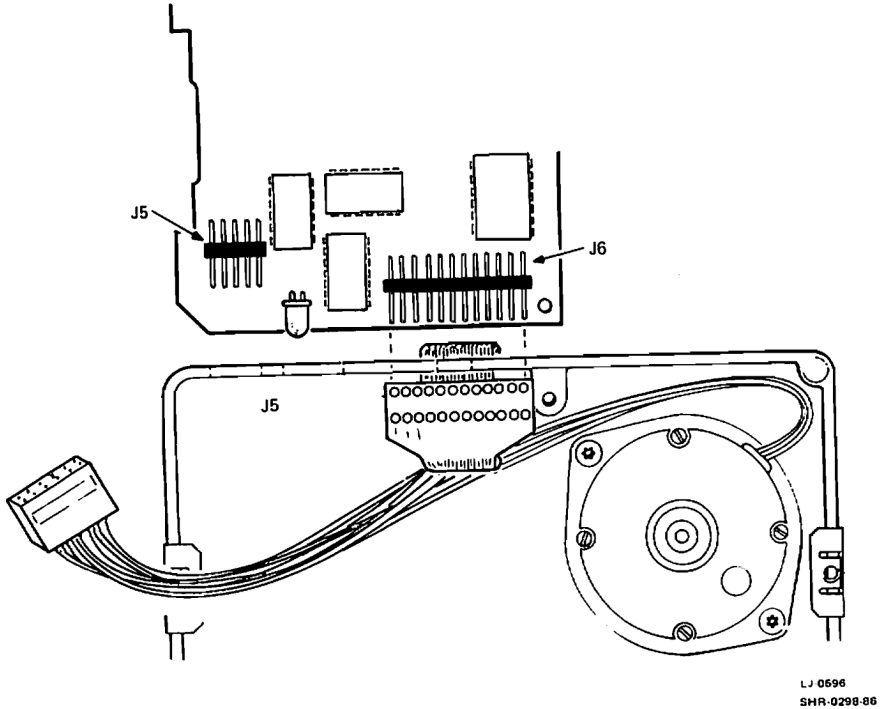

5. Remove the device electronics board from the RD32.

- Position the jumper on the new board to the same position as the jumper on the old board you just removed (Figure 3-28). Also be sure the new board has the resistor termination pack installed.

**Figure 3-28: RD32 Device Electronics Board Jumper Location**

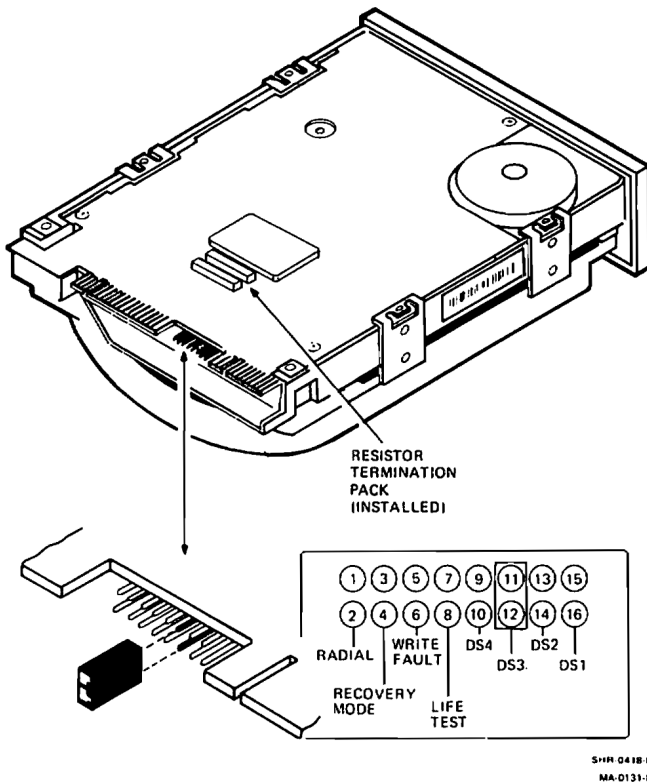

- Replace the new device electronics board by reversing the above procedures.

## 3.9 Resistor Load Board Removal from System Box

The resistor load board loads down the power supply in a diskless system or when just the RX33 floppy drive is installed in the system box. The power supply does not have enough of a load on it to regulate properly in these configurations. The load board simulates the drives by drawing enough power to regulate the power supply. You must remove the load board whenever a hard disk drive is installed in the system box.

The resistor load board in the system box is different from the resistor load board in the expansion boxes. The part number of the resistor load board in the system box must be 5417163-02. The -01 version goes in the expansion boxes.

1. Remove the shield ([Paragraph 3.2](#)).
2. Remove the three screws shown in [Figure 3-29](#) that secure the drive mounting bracket to the chassis.
3. Disconnect the power cable from the resistor load board.
4. Lift the load board up and out of the chassis.
5. If you are removing the load board to install a drive, remove and discard the standoffs that the load board sat on, then install the drive by reversing the removal instructions for that drive. Otherwise, install the new load board (p/n 5417163-02) by reversing the above procedures.

**Figure 3-29: Drive Mounting Bracket Screw Locations**

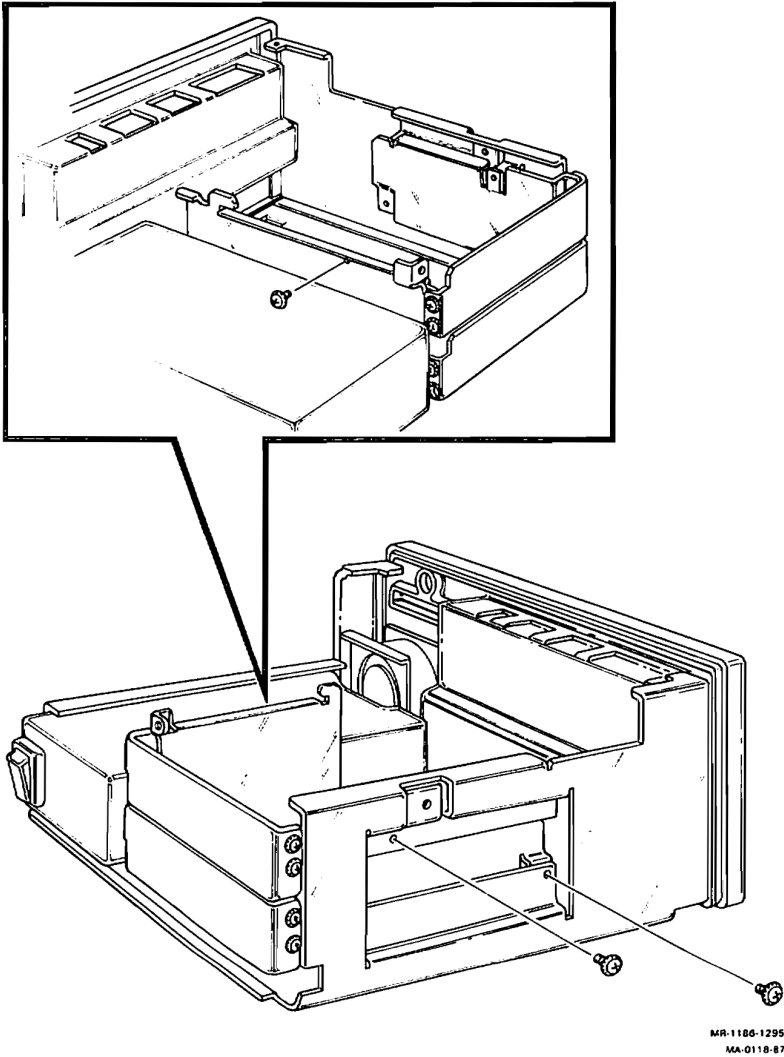

## 3.10 Battery Pack Removal

1. Remove the shield (Paragraph 3.2)
2. Remove the system module assembly from the shield (Paragraph 3.3)
3. Disconnect the battery cable from the system module.

**Figure 3-30: Battery Cable Location**

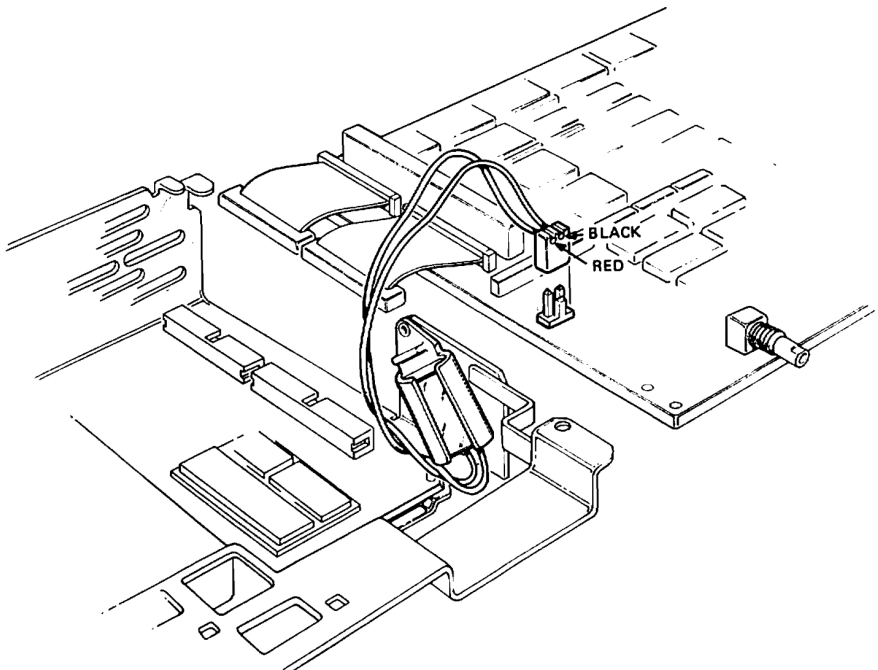

MR-1186-1296  
MA-0078-87

4. Take the battery pack out of its holder.
5. Replace the battery pack by reversing the above procedures.

**NOTE:** A new battery needs a minimum of 25 hours of continuous power on to fully charge the battery. If the battery's charge is low, you will see an error for the NVR when you power up the system.

## 3.11 Power Supply Removal from the System Box

1. Remove the shield ([Paragraph 3.2](#)).
2. Disconnect the power cables from the rear of the drives. If you need more room behind the drives, remove the three drive mounting screws and slide the drives out part way.
3. Put the system on its side and remove the four screws shown in [Figure 3-31](#) that hold the power supply to the bottom of the chassis.

**Figure 3-31: Power Supply Screw Locations in the System Box**

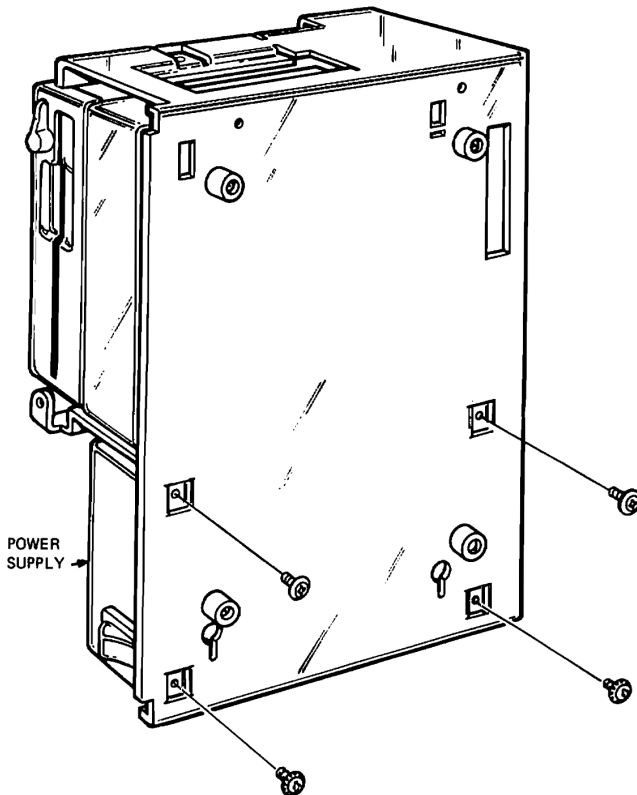

MR-1186-1207  
MA-0127-87

4. Slide the power supply out of the chassis.
5. Replace the power supply by reversing the above procedures.

## 3.12 VAXstation 2000 VR260 Monochrome Monitor

You may need the following tools to repair the VR260 Monitor.

- Phillips screwdriver
- Slotted screwdriver
- High-voltage discharge tool (p/n 29-24717)

Figure 3-32 shows the FRUs in the VR260 monitor.

**Figure 3-32: VR260 FRU Locations**

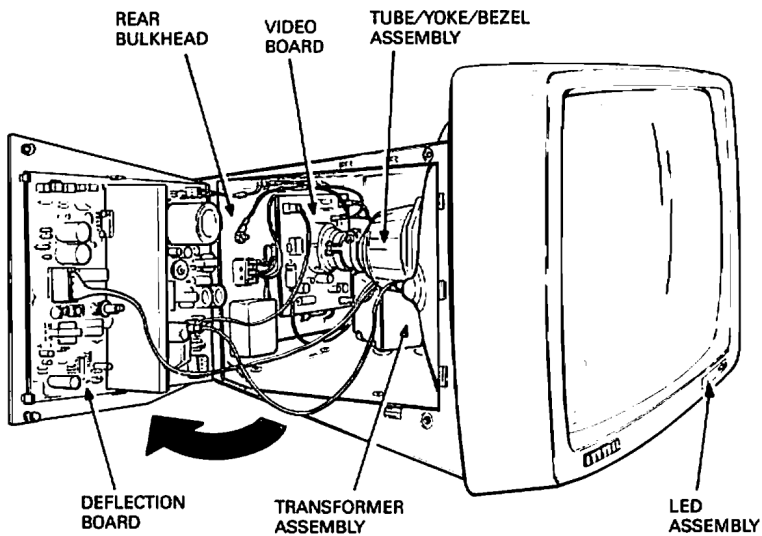

MR-1088-1255  
MA-0088-87

### 3.12.1 VR260 Cover

1. Switch the monitor power switch off.
2. Disconnect the power cord and video cable from the monitor. Refer to [Figure 3-33](#).

**Figure 3-33: VR260 Controls and Video Cable Locations**

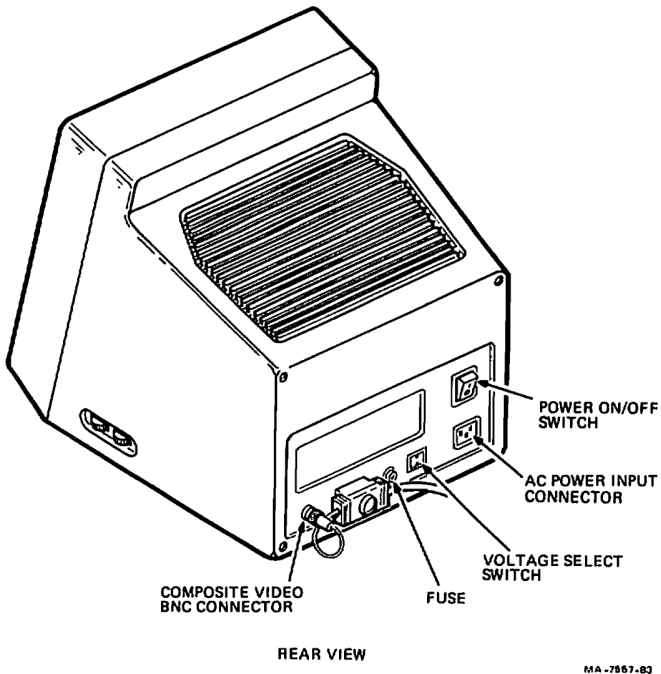

3. Carefully place the monitor on its face.
4. Loosen the four rubber feet on the bottom.
5. Slide the tilt-swivel base up and off the monitor.
6. Finish unscrewing the four rubber feet and remove them from the monitor.

7. Remove the four phillips cover screws shown in [Figure 3-34](#) from the rear of the monitor.

**Figure 3-34: VR260 Cover Screw Locations**

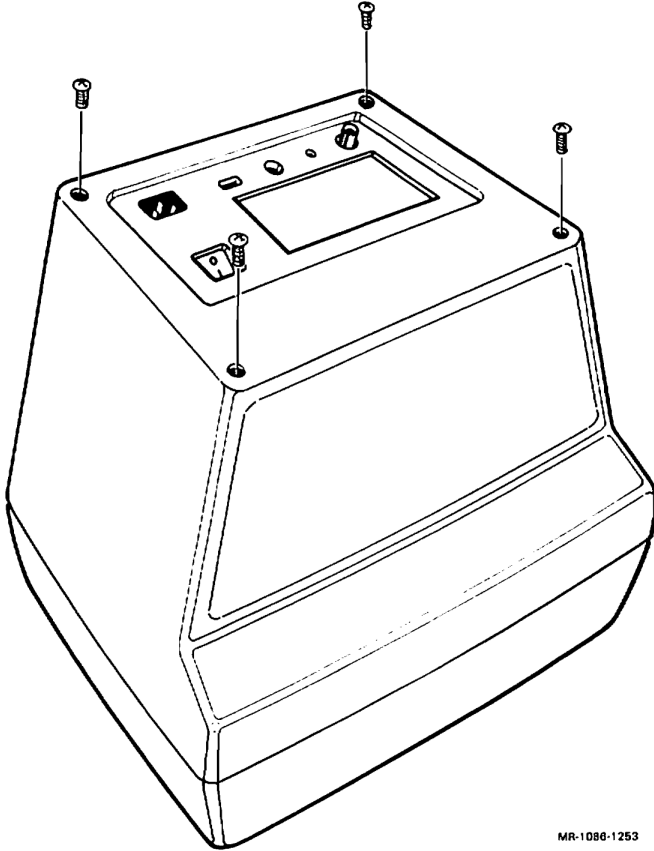

MR-1086-1253  
MA-0089-07

8. Lift the cover off.

9. Lift the bezel off. Refer to [Figure 3-35](#).

**Figure 3-35: VR260 Rear Bezel Location**

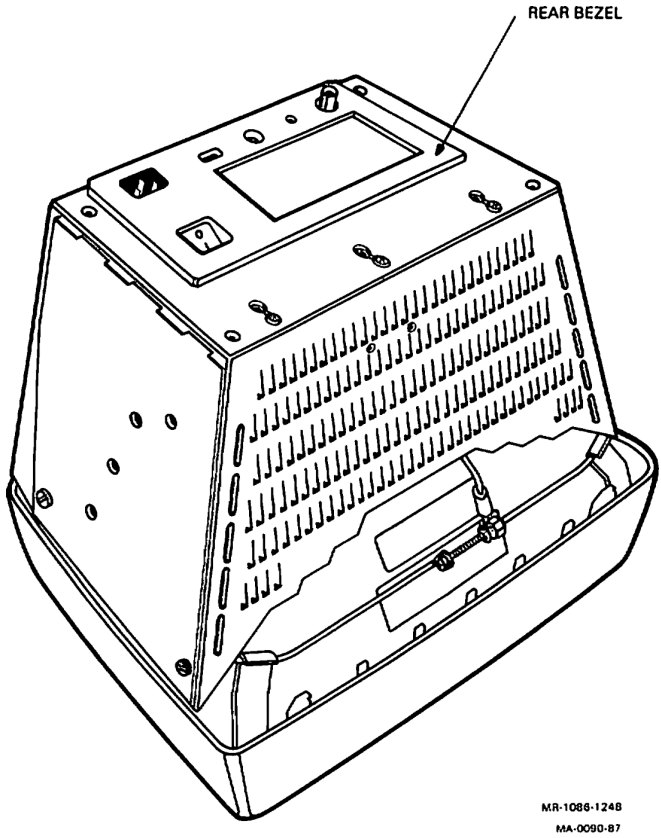

MR-1088-1248  
MA-0090-87

- 10. Place the monitor back down to its normal position.
- 11. Reverse the above procedures to replace the cover.

### 3.12.2 VR260 Deflection Board Removal

The deflection board is mounted inside the chassis door.

1. Remove the monitor cover ([Paragraph 3.12.1](#))
2. Loosen the two 1/4-turn fasteners on the chassis door, and open the door.  
Refer to [Figure 3-36](#).

**Figure 3-36: VR260 Side Door Screw Locations**

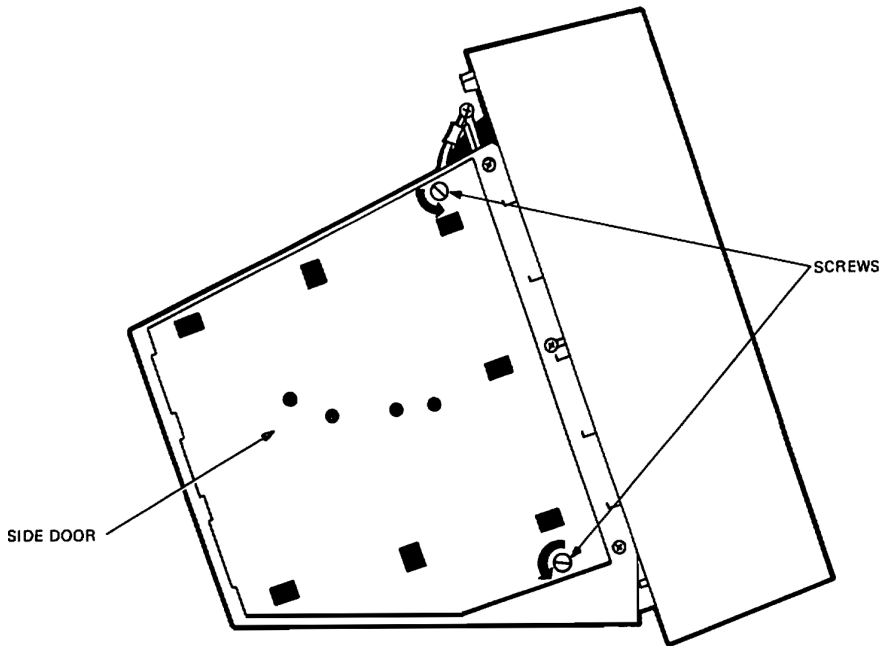

MR-1086-1239  
MA-0091-87

3. Discharge and disconnect the high-voltage anode wire from the cathode ray tube (CRT) as follows.
  - Make sure the monitor's power switch is off.
  - Ground the high-voltage discharge tool (p/n 29-24717) to the tension band or the chassis.
  - Insert the high-voltage discharge tool under the anode cap on the CRT and make contact with the anode clip. Refer to [Figure 3-37](#).

**Figure 3-37: High-Voltage Discharge Tool**

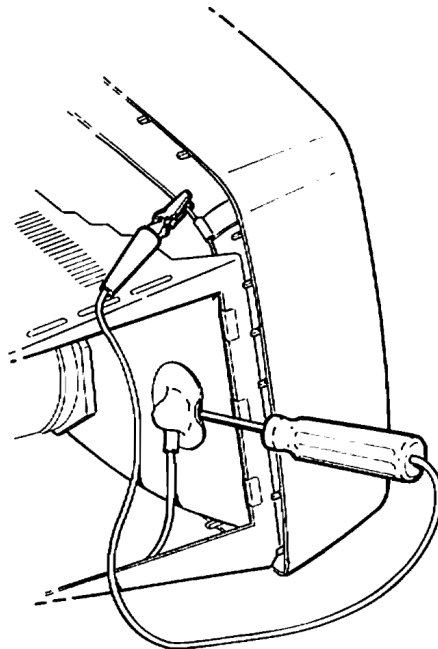

MA-0754-85

- Remove the discharge tool from the monitor.
- Disconnect the high-voltage anode wire from the CRT by squeezing the metal clips inside the cap.

4. Disconnect the following cables from the deflection board. Refer to [Figure 3-38](#) for cable location.
  - CRT yoke (J3)
  - Power transformer (J1, blue and green wires)
  - Slip-on ground (J4)
  - Video board (J5, red and orange wires)
  - Video board (J2)

**Figure 3-38: VR260 Deflection Board**

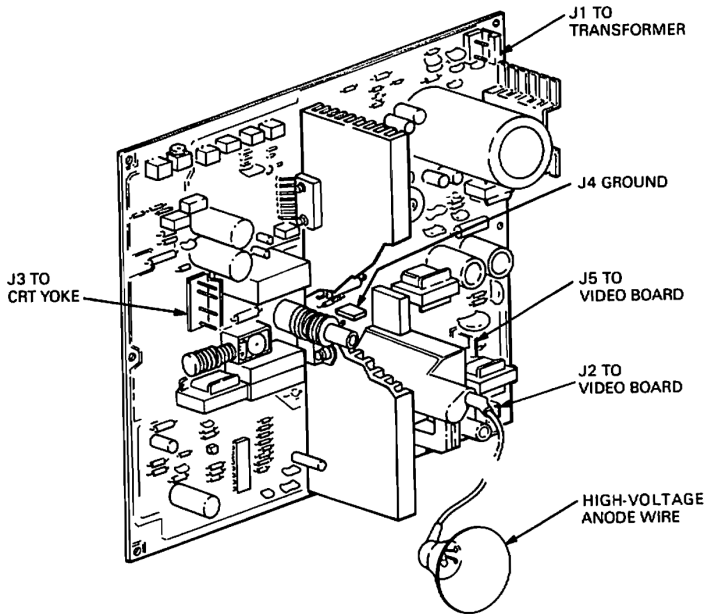

MR-1186-1323  
MA-0130-87

5. Remove the deflection board from the six plastic clips on the chassis door.
6. Reverse the above procedures to replace the deflection board.

### 3.12.3 VR260 Rear Bulkhead Assembly

1. Remove the monitor cover (Paragraph 3.12.1).
2. Carefully place the monitor on its face.
3. Loosen the six keyhole screws shown in Figure 3-39 on the rear bulk head assembly.

**Figure 3-39: VR260 Rear Bulkhead Screw Locations**

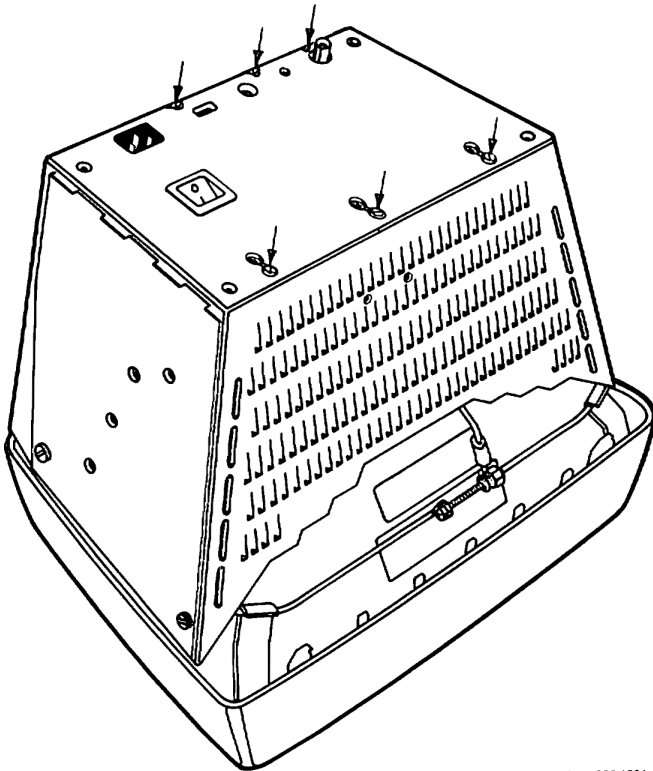

MR-1086-1251  
MA-0092-87

4. Slide the rear bulkhead assembly up and off.

5. Disconnect the video wire from under the video board Refer to [Figure 3-40](#).

**Figure 3-40: VR260 Rear Bulkhead**

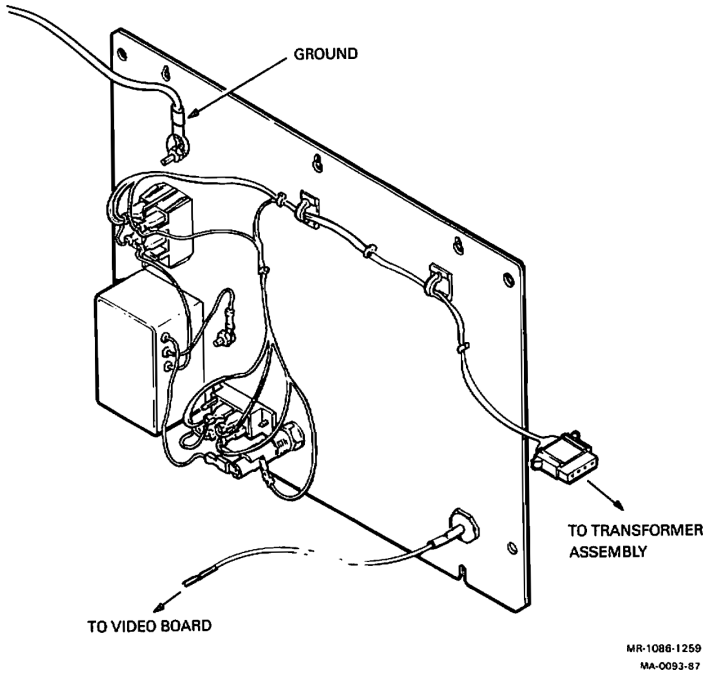

6. Disconnect the cable from the transformer assembly.
7. Disconnect the grounding strap.

**CAUTION:** *Be sure to reconnect the grounding strap when replacing the rear bulkhead assembly.*

8. Reverse the above procedures to replace the rear bulkhead.

### 3.12.4 VR260 Video Board Removal

1. Remove the monitor cover ([Paragraph 3.12.1](#)).
2. Remove the rear bulkhead assembly ([Paragraph 3.12.3](#)).
3. Release the video board from the three standoffs by pressing in on the standoffs and lifting the video board.
4. Refer to [Figure 3-41](#) and disconnect the following cables from the video board.
  - Deflection board (J12)
  - Deflection board (J9)
  - 3-Wire cable (J6)
  - 2-Wire cable (J7)
  - Ground wire (J8, double clip)

**Figure 3-41: VR260 Video Board**

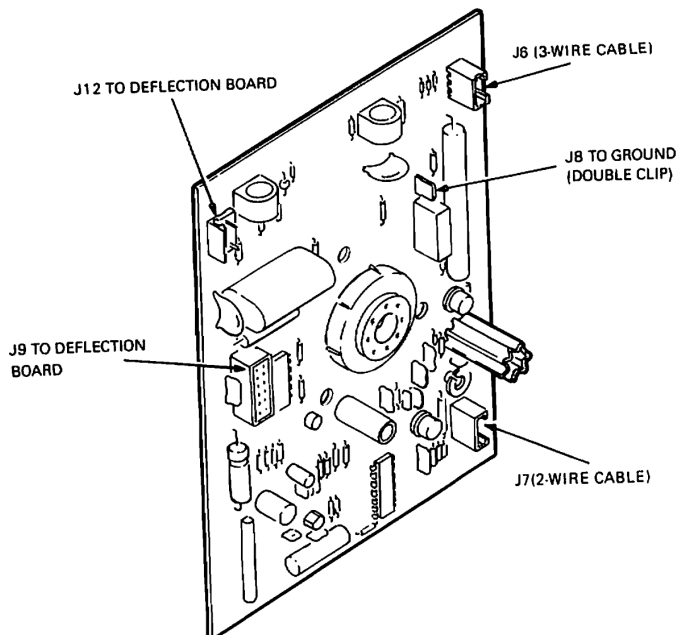

MR-1086-1258  
MA-0129-87

**NOTE:** When replacing the video board, be sure to match the keyed CRT socket on the video board to the pins of the CRT. Squeeze the standoffs while pressing the board onto the CRT.

5. Reverse the above procedures to replace the video board.

### 3.12.5 VR260 Transformer Assembly

1. Remove the monitor cover (Paragraph 3.12.1).
2. Remove the rear bulkhead assembly (Paragraph 3.12.3).
3. Remove the video board (Paragraph 3.12.4).

4. Disconnect the 2-wire cable from the deflection board (J1) and remove this 2-wire cable from the plastic clips (3) on the chassis. Refer to [Figure 3-42](#).

**Figure 3-42: VR260 Transformer Assembly**

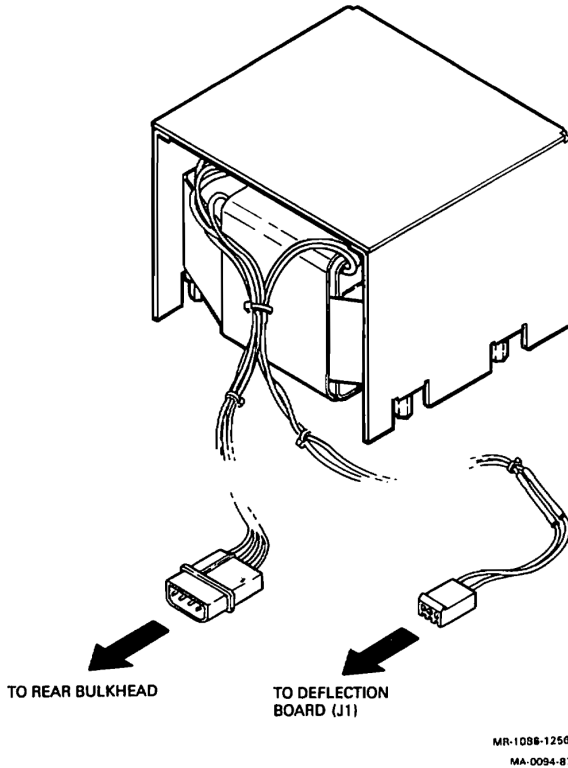

**CAUTION:** *Make sure the transformer does not drop onto the CRT while you remove the four screws in the next step.*

5. Remove the four screws holding the transformer assembly to the bottom of the chassis.
6. Reverse the above procedure to replace the transformer assembly.

### 3.12.6 VR260 Tube/Yoke/Bezel Assembly Removal

The tube/yoke/bezel assembly is made up of the CRT, yoke, and front bezel subassemblies.

1. Remove the monitor cover ([Paragraph 3.12.1](#)).
2. Remove the deflection board ([Paragraph 3.12.2](#)).
3. Remove the rear bulkhead assembly ([Paragraph 3.12.3](#)).
4. Remove the video board ([Paragraph 3.12.4](#)). Put the cable from J12 on the video board aside or leave it connected to the video board so it will not get misplaced.
5. If the tube/yoke/bezel assembly has a braided ground strap attached to the tension band, then remove it from the chassis by unscrewing the grounding screw on the chassis, not from the tension band. The braided ground strap stays connected to the tension band. Unscrew any other braided grounding straps from the chassis.
6. Loosen the middle screws and remove the two outer screws as shown in [Figure 3-43](#). Do this for both sides of the chassis.

**Figure 3-43: VR260 Tube/Yoke/Bezel Assembly Screw Locations**

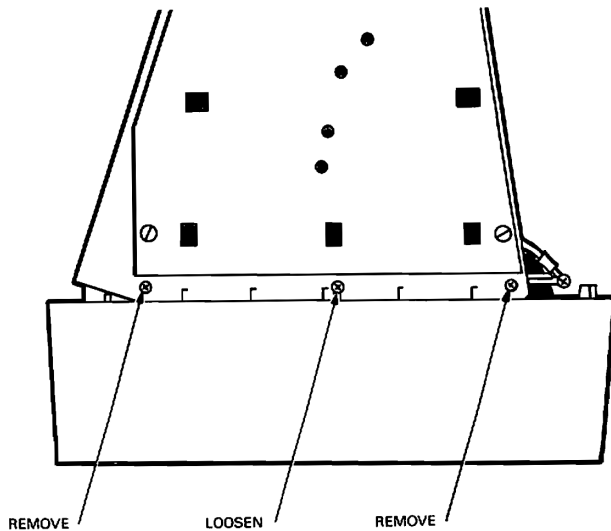

MR-1086-1237  
MA-0095-87

7. Lift the chassis from the tube/yoke/bezel assembly.
8. Place the new tube/yoke/bezel assembly face down and reverse the above procedures to replace the tube/yoke/bezel assembly.

**CAUTION:** *The cable between the deflection board (J2) and the video board (J9) must be connected to the proper locations as shown in [Figure 3-44](#). If you were to connect it backwards, (that is, the LED connector end to the video board) the green LED will not light when power is turned on.*

**Figure 3-44: VR260 Tube/Yoke/Bezel Assembly's LED Cable**

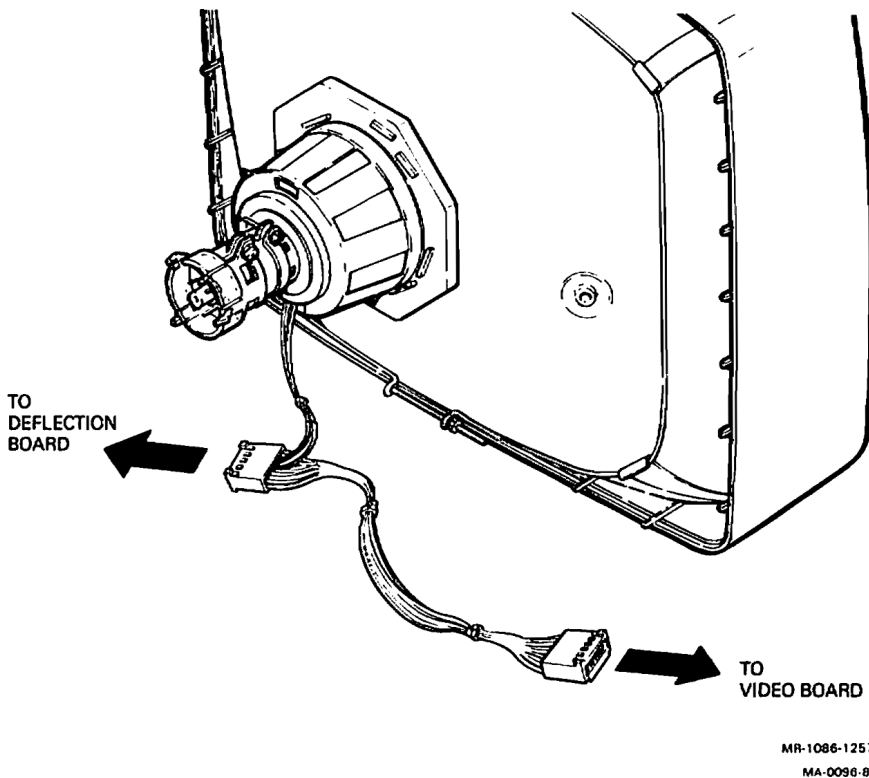

[Figure 3-45](#) shows the cable connections for the VR260 monochrome monitor.

Reverse the procedure in Paragraph 3.12.1.

**Figure 3-45: VR260 Cable Connections**

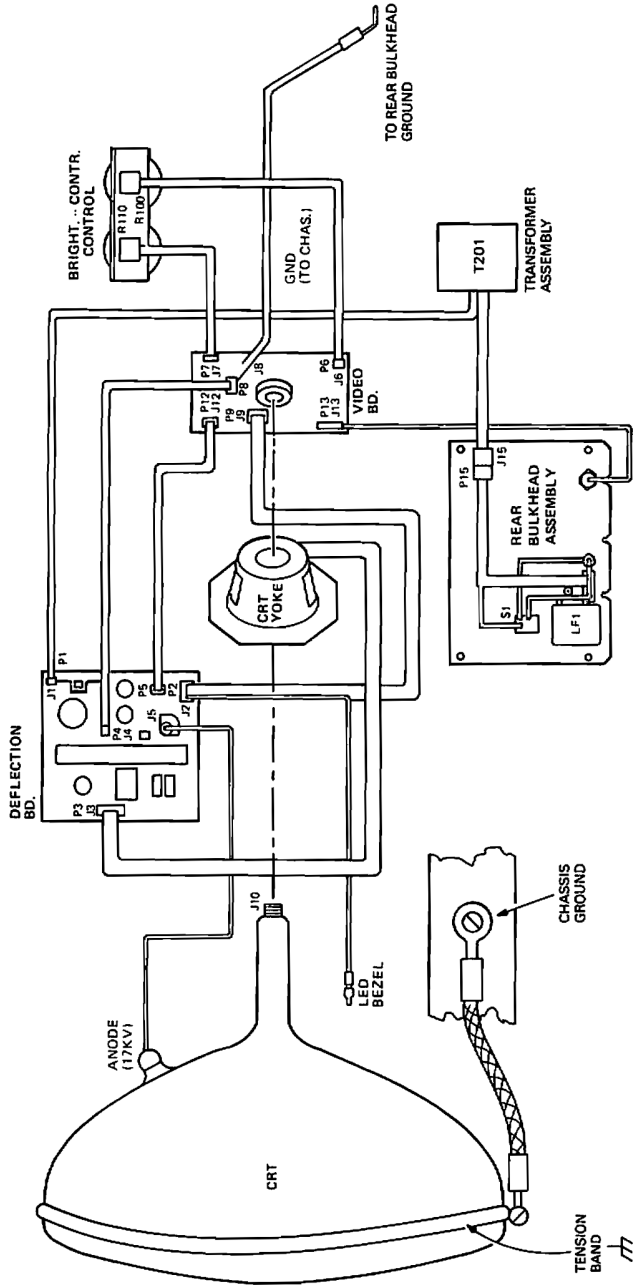

MR-106B-1260  
MA-0097.97

### 3.12.7 VR260 LED Assembly

Use a small-bladed screwdriver or a similar tool for the following procedure.

1. Carefully pry the LED/bezel assembly off the monitor. Refer to [Figure 3-46](#).

**Figure 3-46: VR260 LED/Bezel Assembly**

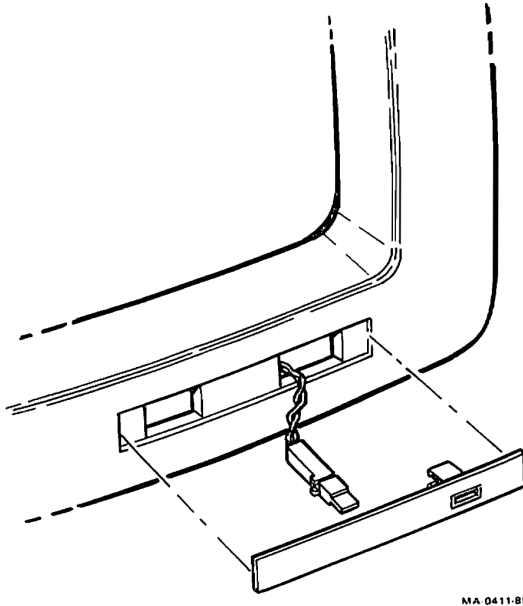

2. Disconnect the LED wires.

To replace the LED/bezel assembly, do the following.

1. Connect the LED wires to the LED/bezel assembly. The black wire is connected to the notched connector leg.
2. Remove the protective paper backing from the double-sided tape on the LED/bezel assembly.
3. Press the LED/bezel assembly in place.

### 3.13 Keyboard Removal (VAXstation 2000 only)

1. Unplug the keyboard cable from the rear of the monitor. Refer to [Figure 3-47](#).

**NOTE:** *The keyboard is a Single FRU. Do not try to remove the keycaps or disassemble the keyboard.*

**Figure 3-47: Disconnecting the Keyboard (VAXstation 2000)**

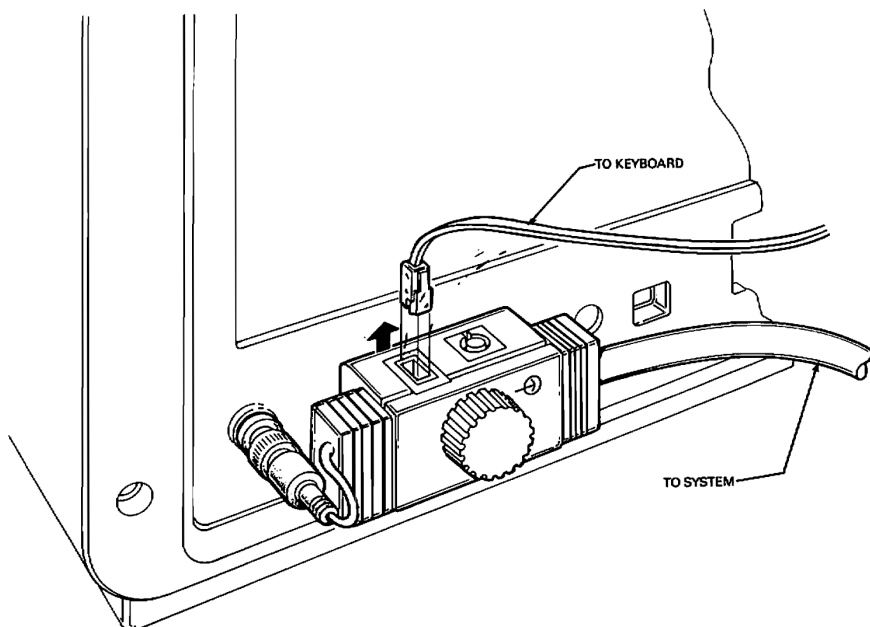

MR-1190-1332  
MA-0020-07

### 3.14 Mouse and Tablet (VAXstation 2000 only)

1. Disconnect the mouse or tablet from the monitor's cable. Refer to [Figure 3-48](#).

**NOTE:** *The mouse and the tablet are Single FRUs. Do not try to disassemble them.*

**Figure 3-48: Disconnecting the Mouse or Tablet (VAXstation 2000)**

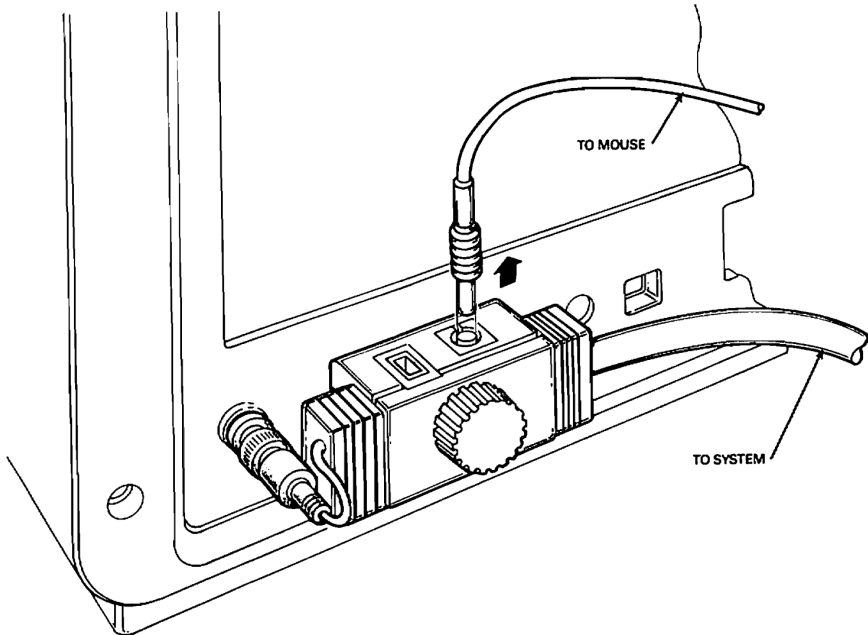

MR-1180-1333  
MA-0099-87

## 3.15 Terminal Disconnection from MicroVAX 2000

1. Switch off the terminal's power switch.
2. Disconnect the cable from the COMM connector on the back of the terminal.
3. Refer to the terminal's pocket service guide for troubleshooting and removal and replacement procedures for the terminal.

### 3.15.1 DEC423 Converter Removal from MicroVAX 2000

1. Switch off MicroVAX 2000's power.
2. Unscrew two screws on the bottom of the DEC423 converter as shown in [Figure 3-49](#) and remove the DEC423 Converter from the back of the MicroVAX 2000 system box.

**Figure 3-49: DEC423 Converter's Mounting Screw Locations**

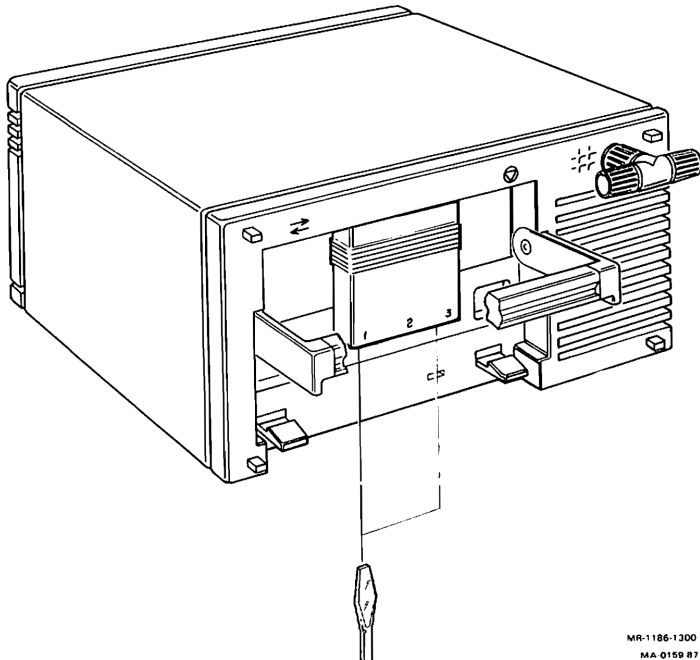

MR-1186-1300  
MA 0159 B7

3. One at a time, disconnect the cables from the converter you are removing and reconnect them to the same connectors on the new converter.
4. Connect the new converter to the back of the MicroVAX 2000 system box and screw in the two mounting screws.

## 3.16 Expansion Adapter Removal

The expansion adapter is not an FRU. There is one FRU module located inside the expansion adapter called the disk interface module. There is also an interface cable for the tape drive expansion box that passes through the expansion adapter and attaches directly to connector A on the back of the expansion adapter. Removal procedures for the expansion adapter are below. The removal and replacement information for the disk interface module is in [Paragraph 3.16.1](#).

1. Remove the shield ([Paragraph 3.2](#))
2. Remove the four screws shown in [Figure 3-50](#) that hold the expansion adapter to the bottom of the System.

**Figure 3-50: Expansion Adapter Screws**

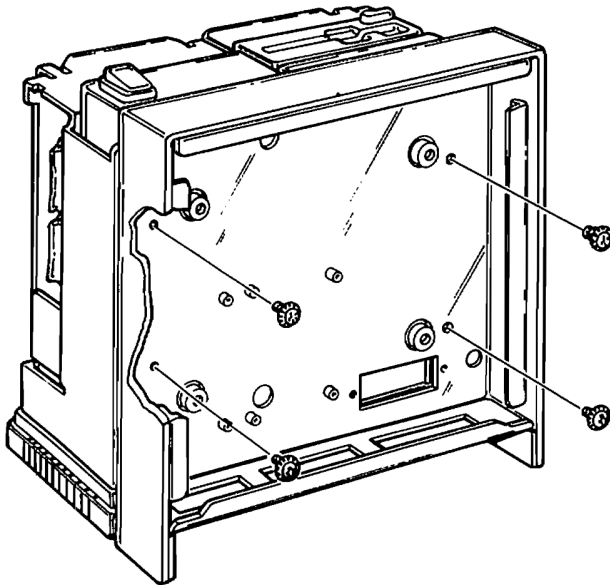

MR-1186-1302  
MA-0100-87

3. Disconnect the disk expansion cables from the disk interface module. Refer to [Figure 3-51](#).

**Figure 3-51: Expansion Cables Locations**

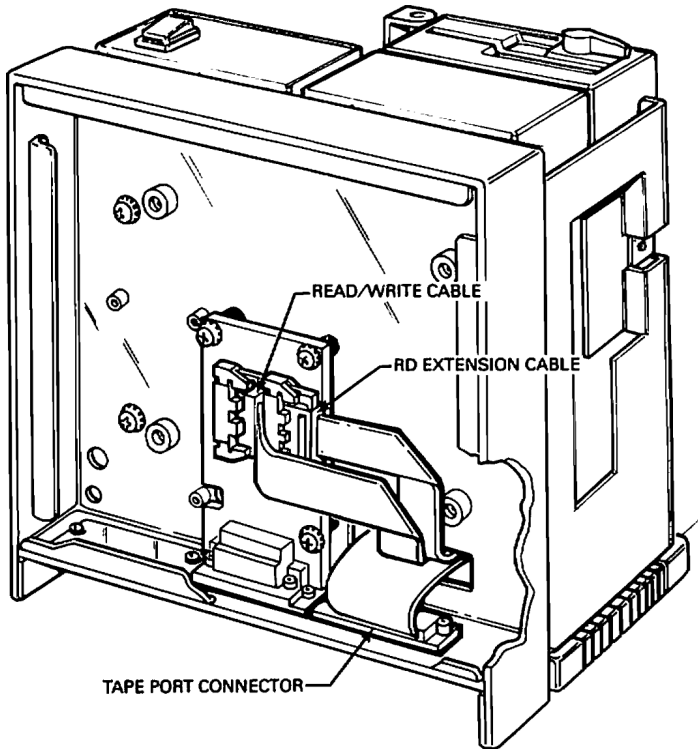

MR-1188-1334  
MA-0101-87

4. Unscrew the tape port connector from the expansion adapter.
5. Replace the expansion adapter by reversing the above procedures.

### 3.16.1 Expansion Adapter Disk Interface Module Removal

1. Switch off power to the System.
2. Put the system box on its side and remove the two cover screws shown in [Figure 3-52](#) and remove the cover.

**Figure 3-52: Expansion Adapter Cover Screws Location**

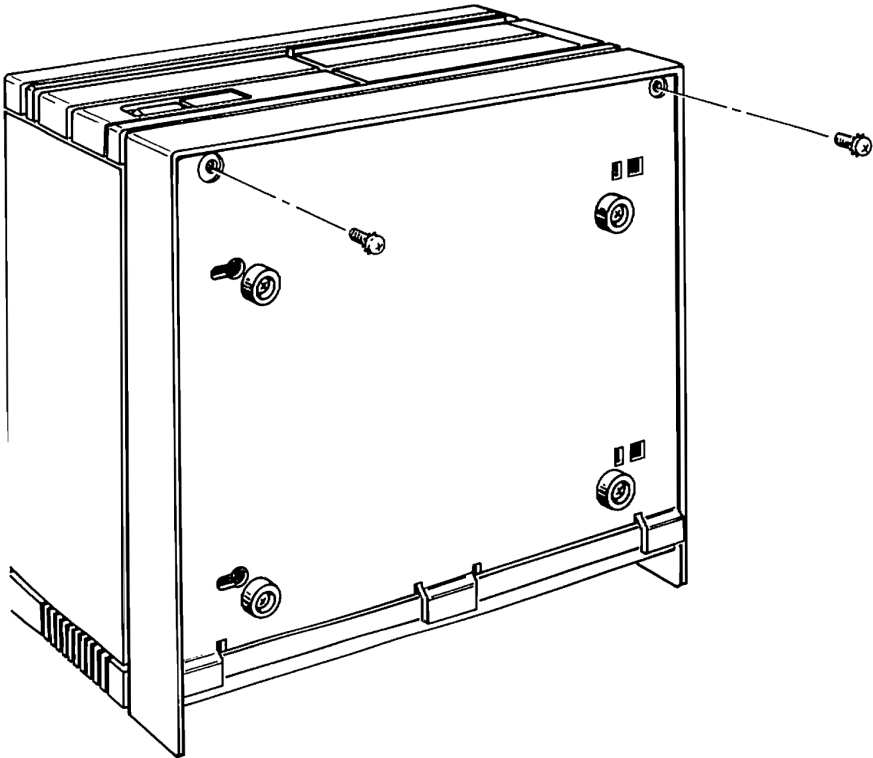

MR-1186-1276  
MA-0069-87

3. Disconnect the cables to the disk interface module and remove the three screws shown in [Figure 3-53](#).

**Figure 3-53: Expansion Adapter Disk Interface Module Cables and Screw Locations**

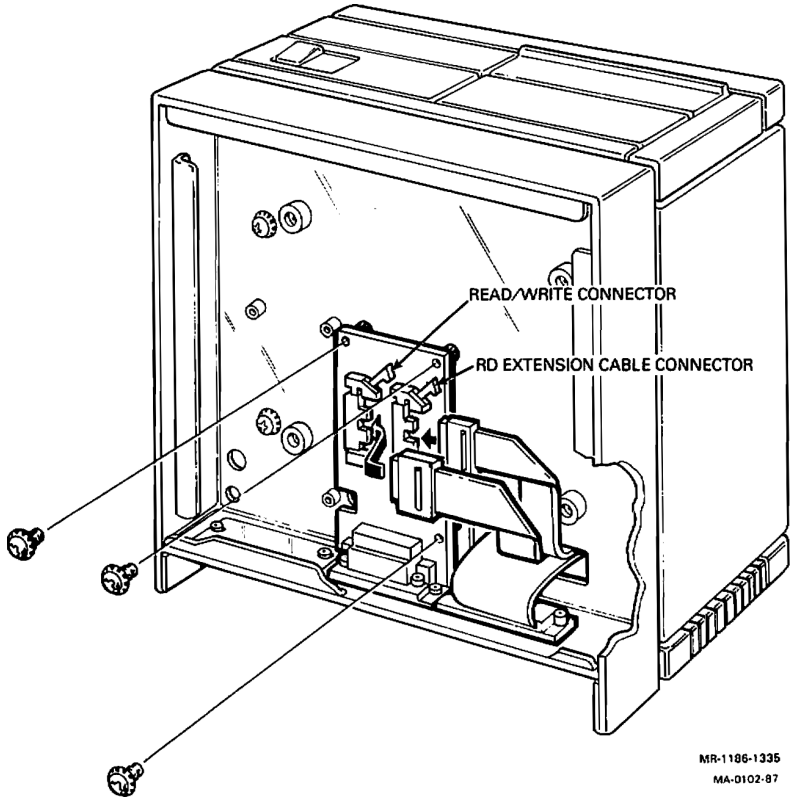

4. Reverse the above procedure to replace the disk interface module.

## **3.17 VAXstation 2000 and MicroVAX 2000 Expansion Box**

There are two configurations of expansion boxes and both configurations are available for the VAXstation 2000 and MicroVAX 2000 systems. One configuration consists of an RD53 hard disk drive in an expansion box for 70 megabytes of storage memory. Another configuration consists of a TK50 tape drive with a TZK50 controller board in an expansion box for 94.5 megabytes of storage memory.

The expansion box with the hard disk contains five FRUs. They are the disk, disk device electronics board inside the disk, a resistor load board, the power supply, and the expansion box itself. The expansion box with the tape drive also contains five FRUs. They are the TK50 tape drive, TZK50 controller board, a resistor load board, the power supply, and the expansion box itself.

Paragraph 3.17.1 contains removal procedures for the hard disk drive expansion box and Paragraph 3.17.2 contains removal procedures for the tape drive expansion box.

### **3.17.1 Hard Disk Drive Expansion Box Disconnection from System Box**

1. Switch off power to the expansion box.
2. Disconnect the power cable on the expansion box from the wall plug and then from the expansion box.

3. Disconnect the hard disk drive expansion box cable shown in [Figure 3-54](#) from the back of the expansion box.

**Figure 3-54: Hard Disk Expansion Box Cable**

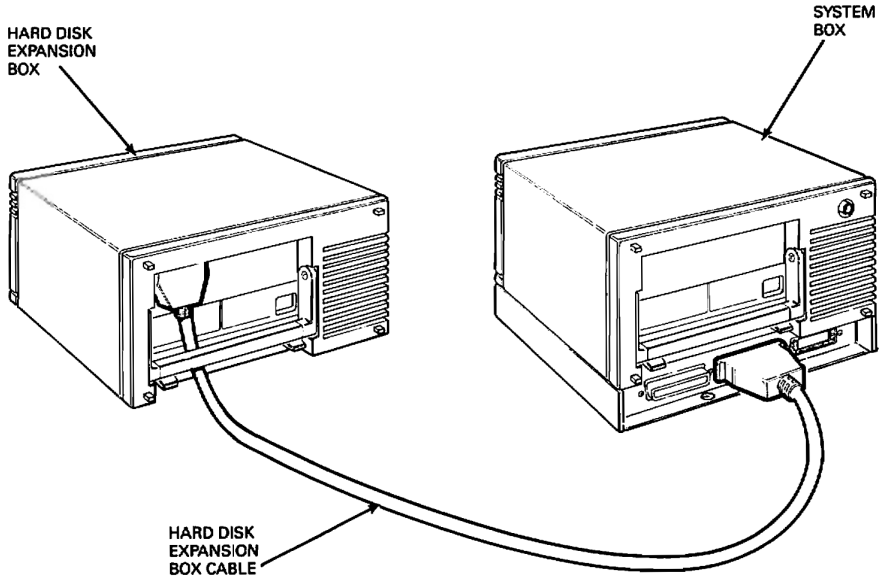

MR-1186-1304  
MA-0103-07

### 3.17.1.1 Hard Disk Drive Removal from Hard Disk Expansion Box

1. Switch off power to the expansion box.
2. Unscrew the four screws shown in [Figure 3-55](#) and remove the expansion box cover.

**Figure 3-55: Hard Disk Expansion Box Cover Screw Locations**

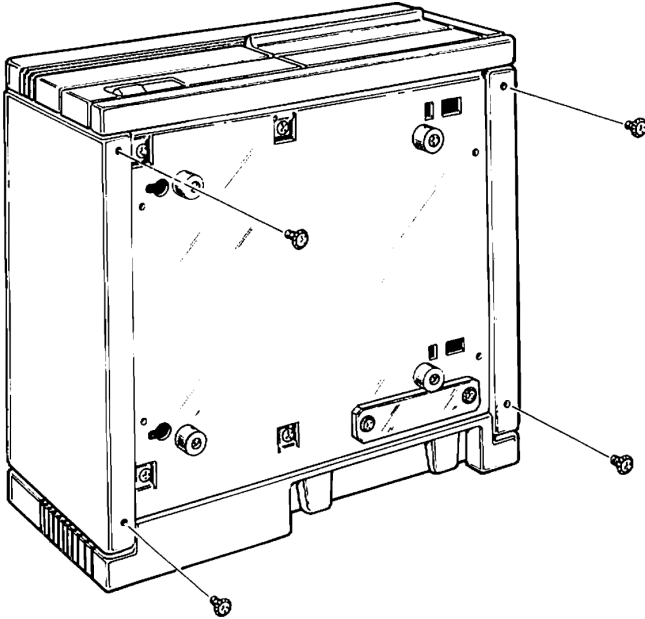

MR-1188-1305  
MA-0104-87

3. Disconnect the power cable shown in [Figure 3-56](#) from the resistor load board.

**Figure 3-56: Resistor Load Board Power Cable**

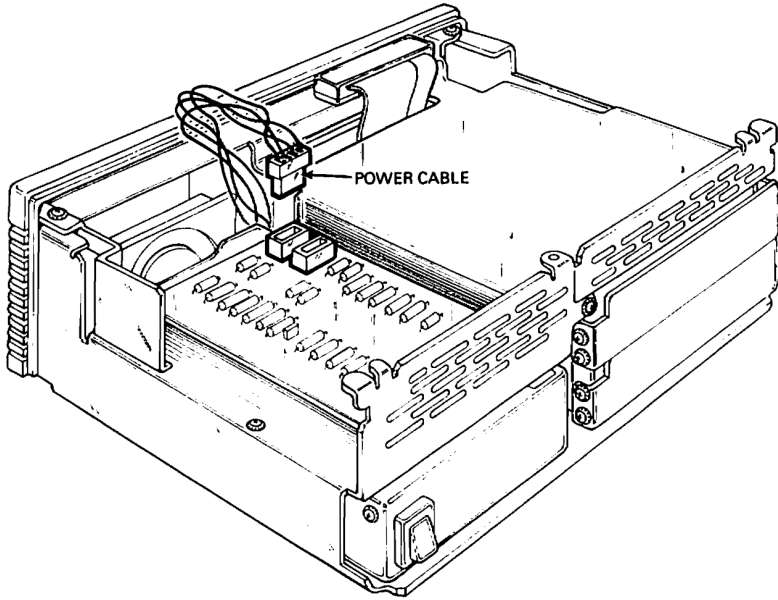

MR-1186-1306  
MA-0105-07

4. Remove the five screws shown in [Figure 3-57](#) that hold the shield to the main chassis.

**Figure 3-57: Hard Disk Expansion Box Shield Screw Locations**

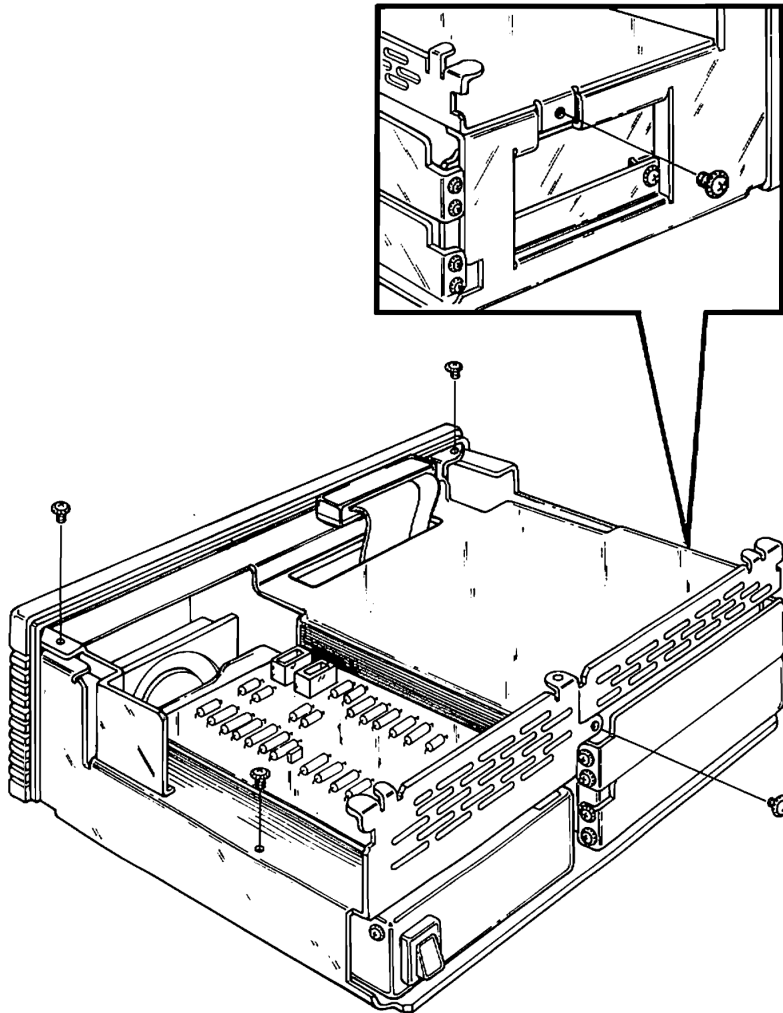

MR-1189-1307  
MA-0106-87

5. Lift the shield up and off to the side of the expansion box.
6. Remove the three drive mounting screws shown in [Figure 3-58](#).

**Figure 3-58: Hard Disk Expansion Box Drive Mounting Screws**

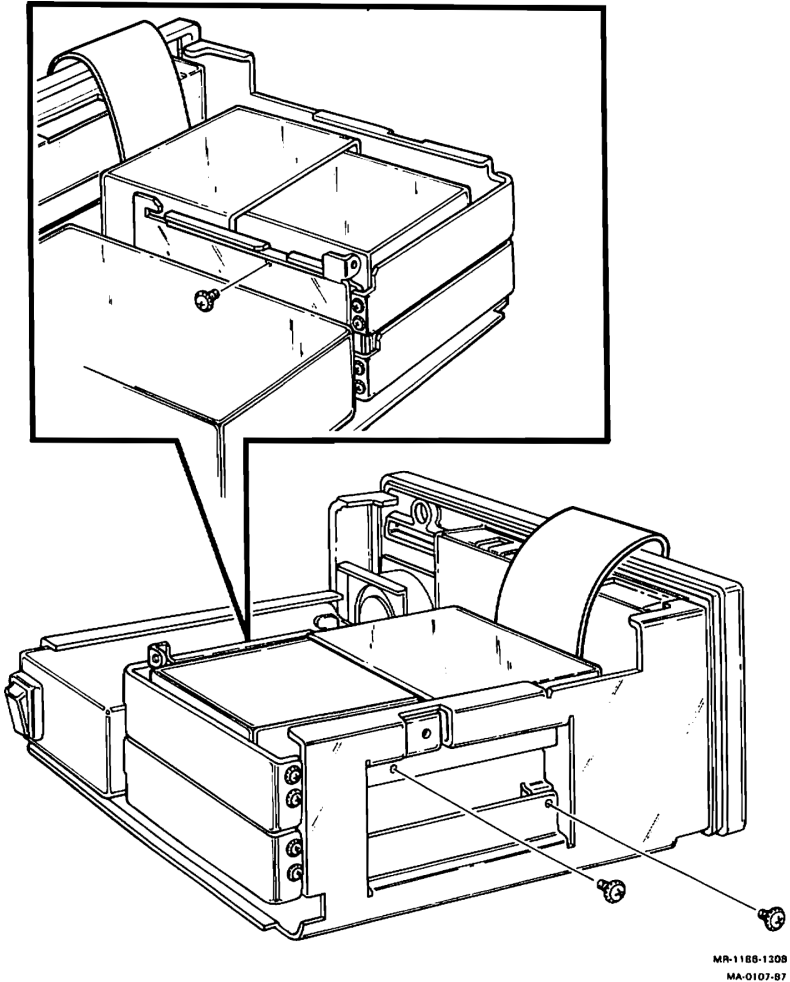

7. Slide the drive out halfway and disconnect the two data cables and the power cable from the back of the drive, then remove the drive. See [Figure 3-59](#).

**Figure 3-59: Hard Disk Expansion Box Drive Cables Locations**

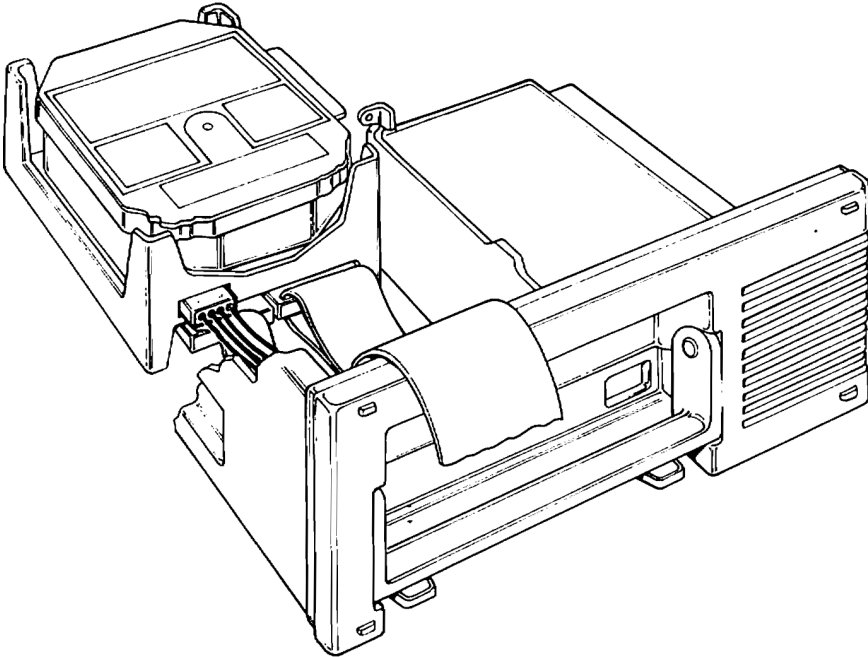

MR-1186-1309  
MA-0108-87

8. Remove the four screws shown in [Figure 3-60](#) and remove the mounting bracket from the drive.

**Figure 3-60: Hard Disk Expansion Box Drive Mounting Bracket Screws Location**

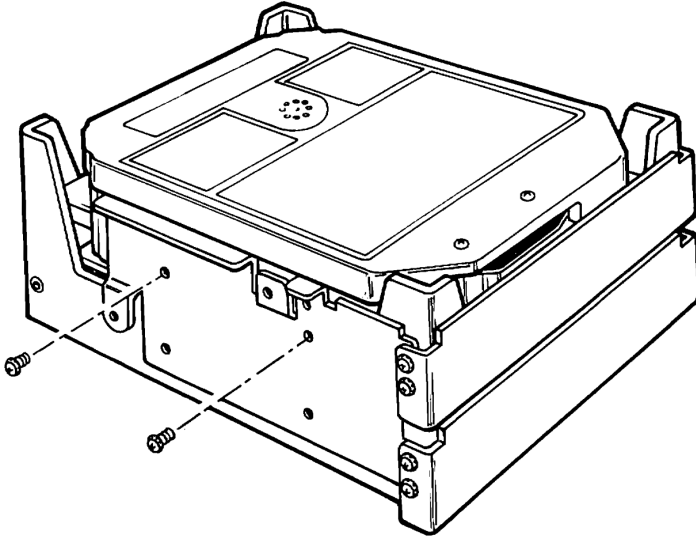

MR-1186-1292  
MA-0084-87

9. If you removed an RD53 because of an error with the drive, go to [Paragraph 3.7.1](#) to replace the device electronics board. Replace the RD53 by reversing the above procedure.

### 3.17.1.2 Power Supply Removal from the Hard Disk Expansion Box

1. Switch off power to the expansion box.
2. Unscrew the four screws shown in [Figure 3-61](#) and remove the expansion box cover.

**Figure 3-61: Hard Disk Expansion Box Cover Screw Locations**

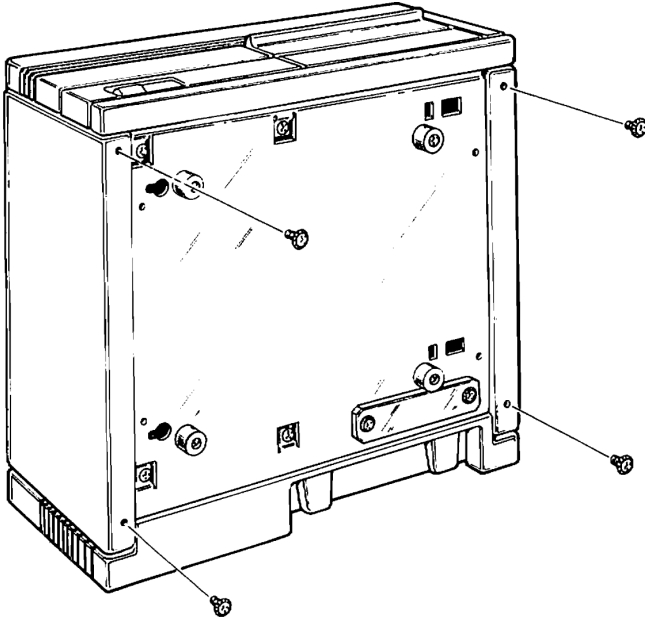

MR-1100-1305  
MA-0104-07

3. Disconnect the power cable shown in [Figure 3-62](#) from the resistor load board.

**Figure 3-62: Hard Disk Expansion Box Resistor Load Board Power Cable**

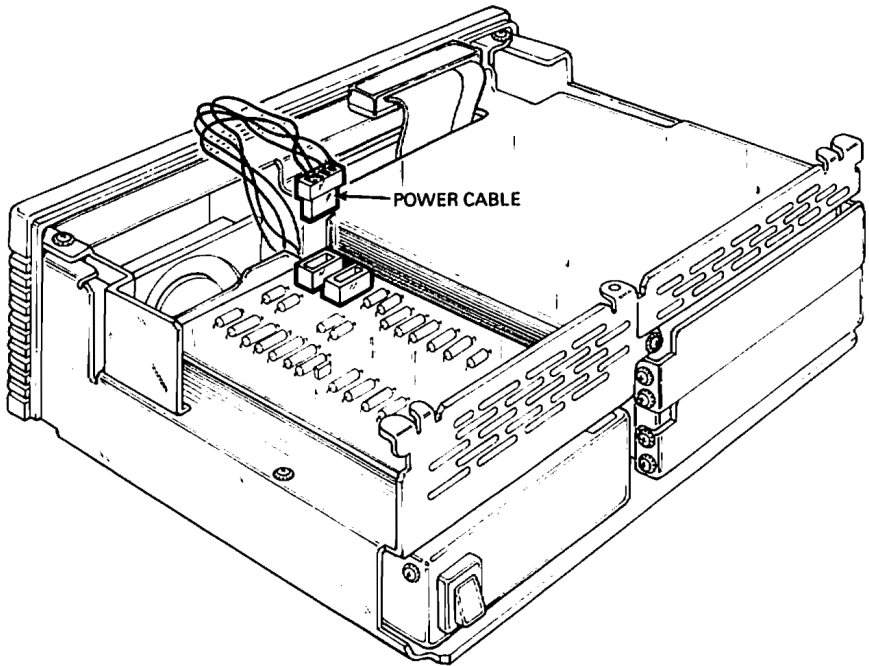

MR-1186-1306  
MA-0105-87

4. Remove the five screws shown in Figure 3-63 that hold the shield to the main chassis.

**Figure 3-63: Hard Disk Expansion Box Shield Screw Locations**

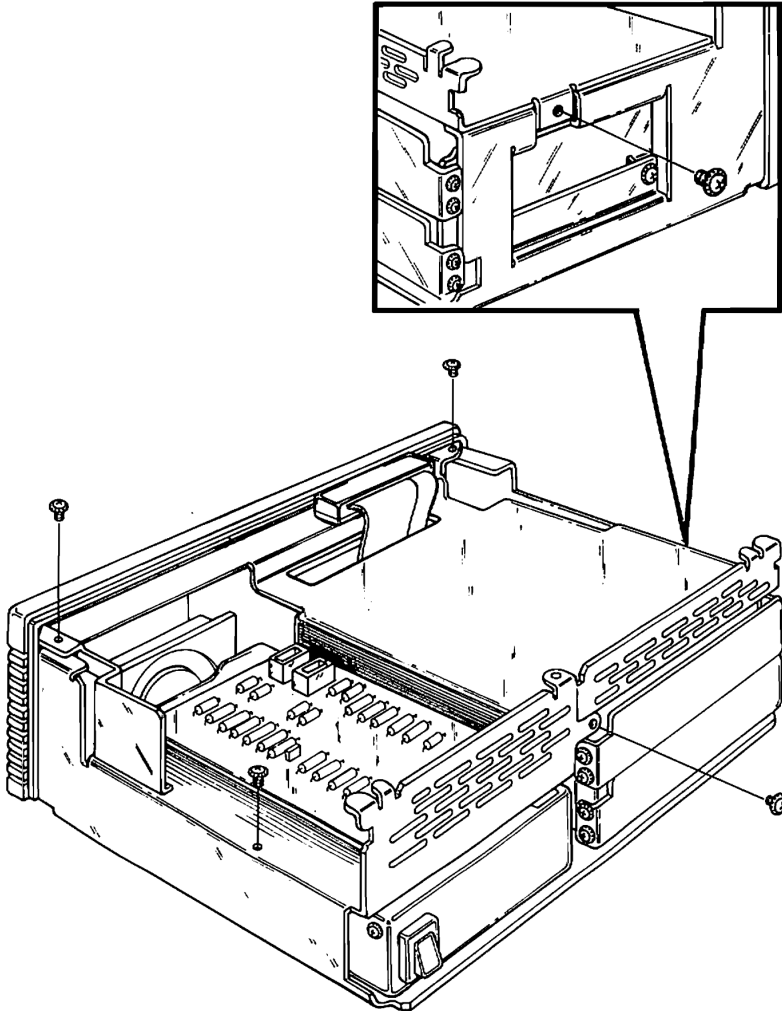

MR-1189-1307  
MA-0106-87

5. Lift the shield up and hold it with one hand and disconnect the power cable from the drive with the other hand.
6. Tip the expansion box on its side and remove the four screws shown in [Figure 3-64](#) that hold the power supply to the chassis.

**Figure 3-64: Hard Disk Expansion Box Power Supply Mounting Screw Locations**

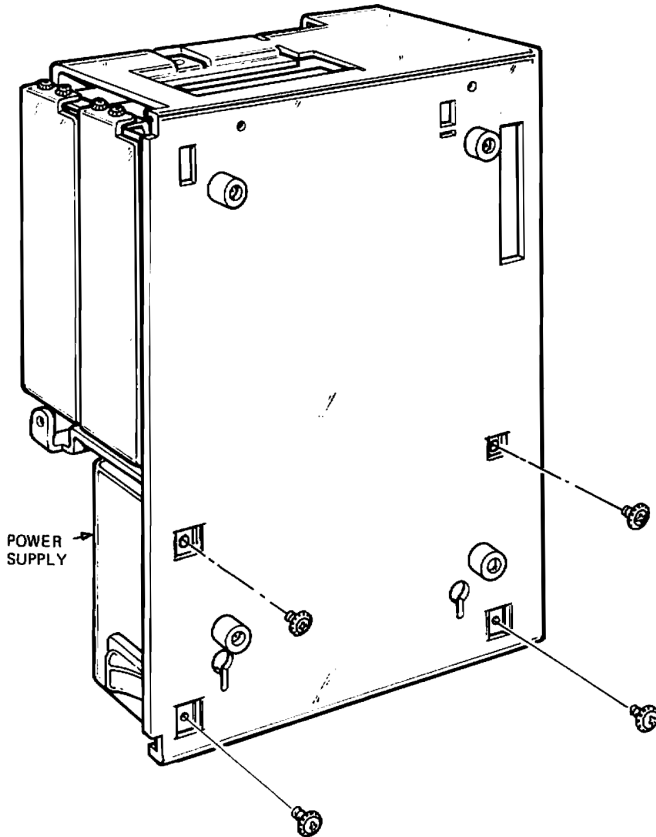

MR-1186-1310  
MA 0157-87

**NOTE:** One of the power supply cables has an extension cable on it. You must remove this extension from the power supply you are removing and connect it to the same cable on the new power supply.

7. Replace the power supply by reversing the above procedure.

### 3.17.1.3 Resistor Load Board Removal from the Hard Disk Expansion Box

The resistor load board in the expansion box is different from the resistor load board in the system box. The part number for the resistor load board in the expansion box is 5417163-01. The -02 version is for the system box.

1. Switch off power to the expansion box.
2. Unscrew the four screws shown in [Figure 3-65](#) and remove the expansion box cover.

**Figure 3-65: Hard Disk Expansion Box Cover Screw Location**

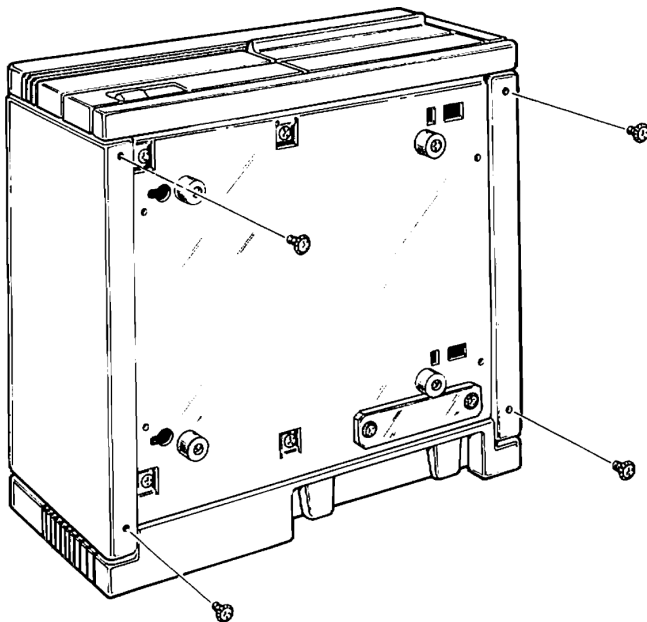

MR-1188-1305  
MA-0104-87

3. Disconnect the power cable from the resistor load board Refer to [Figure 3-66](#).

**Figure 3-66: Hard Disk Expansion Box Resistor Load Board Power Cable**

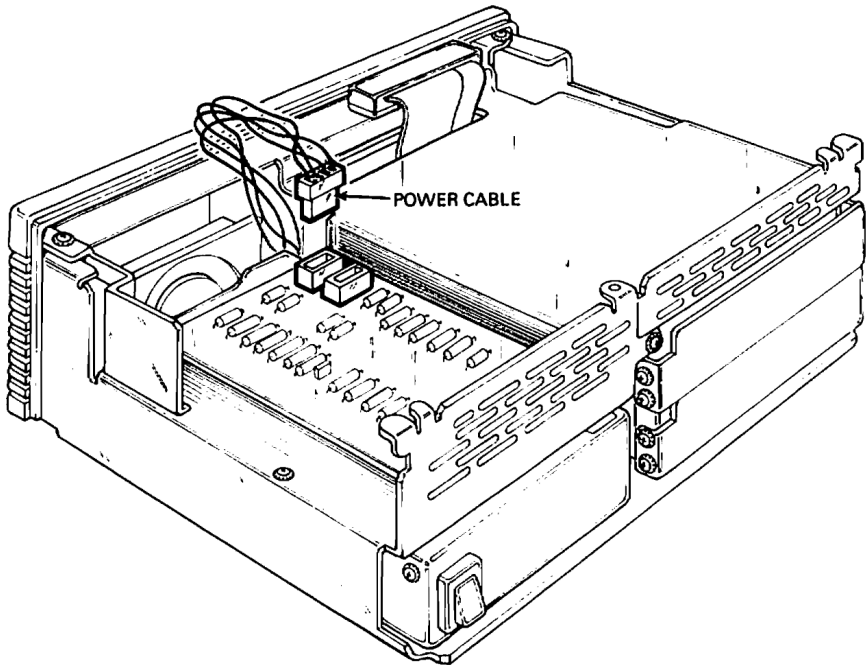

MR-1188-1306  
MA-0105-07

4. Remove the resistor load board from the shield.
5. Replace the resistor load board by reversing the above procedure.

### 3.17.2 Tape Drive Expansion Box Disconnection from System Box

1. Switch off power to the expansion box.
2. Disconnect the power cable on the expansion box from the wall plug and then from the expansion box.
3. Disconnect the tape drive expansion box cable shown in [Figure 3-67](#) from the back of the expansion box.

**Figure 3-67: Tape Drive Expansion Box Data Cable**

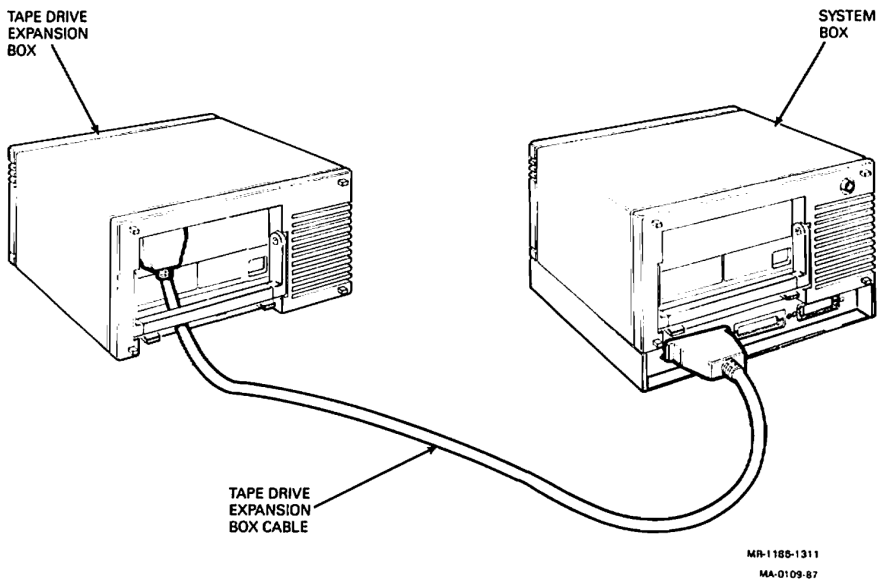

### 3.17.2.1 TZK50 Controller Board Removal from the Tape Drive Expansion Box

1. Switch off power to the expansion box.
2. Unscrew the four screws shown in [Figure 3-68](#) and remove the expansion box cover

**Figure 3-68: Tape Drive Expansion Box Cover Screw Locations**

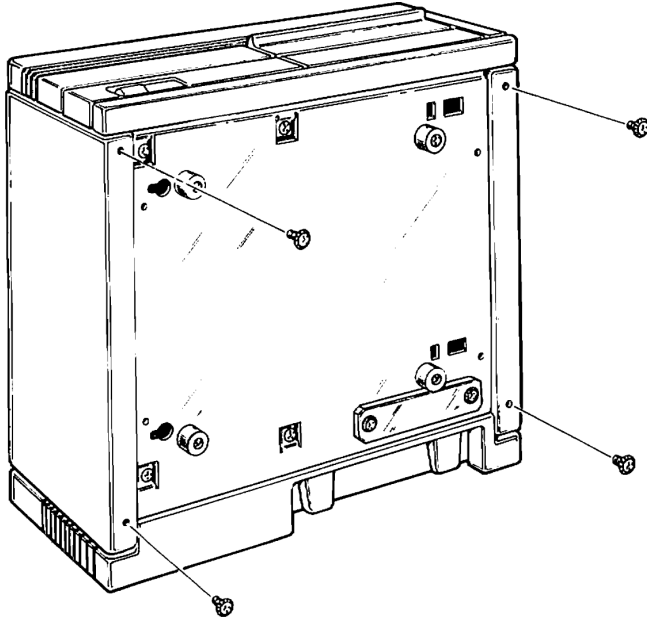

MR-1186-1305  
MA-0104-07

3. Disconnect the tape data cable (J3), the TK50 tape drive I/O cable (J1), and the power cable (P1) from the TZK50 controller board. Refer to [Figure 3-69](#).

**Figure 3-69: TZK50 controller Board Cable Locations**

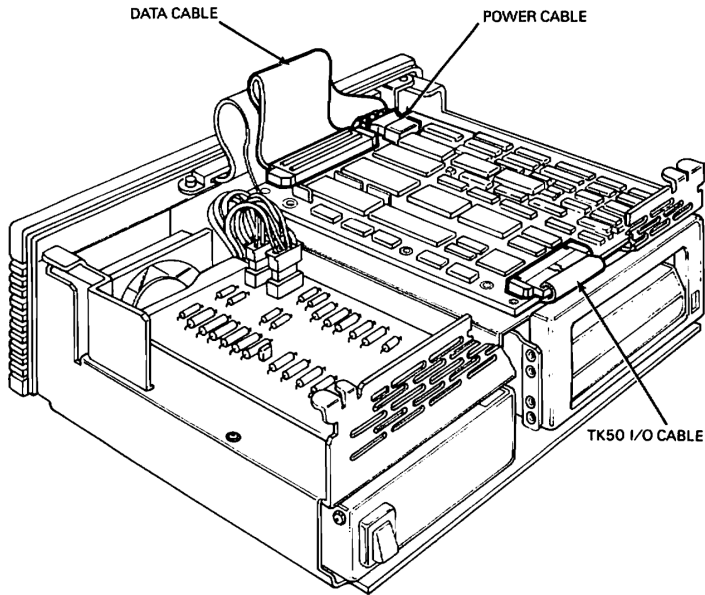

MR-118B-1312  
MA-0110-87

4. Remove the TZK50 controller board from the shield.
5. Set the jumpers on the new TZK50 controller board in the same position as they are on the old TZK50 controller board you just removed (see [Figure 3-70](#)). If the old board does not have the three resistor packs installed (Z7, Z6, and Z8), remove them from the new board. [Figure 3-70](#) shows the TZK50 controller board configured for ID address 1, with parity checking enabled, and internal diagnostics disabled.
6. Replace the TZK50 controller board by reversing the above procedure.

Reverse the procedure in Paragraph 3.12.1.

**Figure 3-70: TZK50 Controller Board Jumper and Resistor Pack Locations**

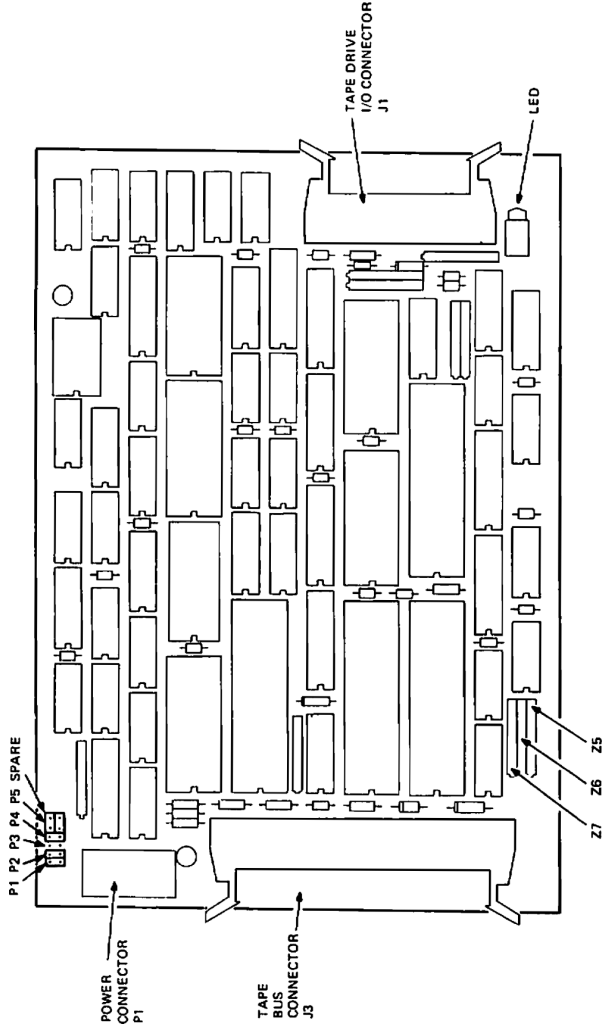

ADDRESS ID	P1	P2	P3
0	Installed	Installed	Installed
1	Installed	Installed	Removed
2	Installed	Removed	Installed
3	Installed	Removed	Removed
4	Removed	Installed	Installed
5	Removed	Removed	Removed
6	Removed	Installed	Installed
7	Removed	Removed	Removed

### 3.17.2.2 TK50 Tape Drive Removal from Tape Drive Expansion Box

1. Remove the TZK50 Controller board (Paragraph 3.17.2.1).
2. Disconnect the power cable on the resistor load board that comes from the power supply.
3. Unscrew the five screws shown in Figure 3-71 that secure the shield to the main chassis.

**Figure 3-71: Tape Drive Expansion Box Shield Screw Locations**

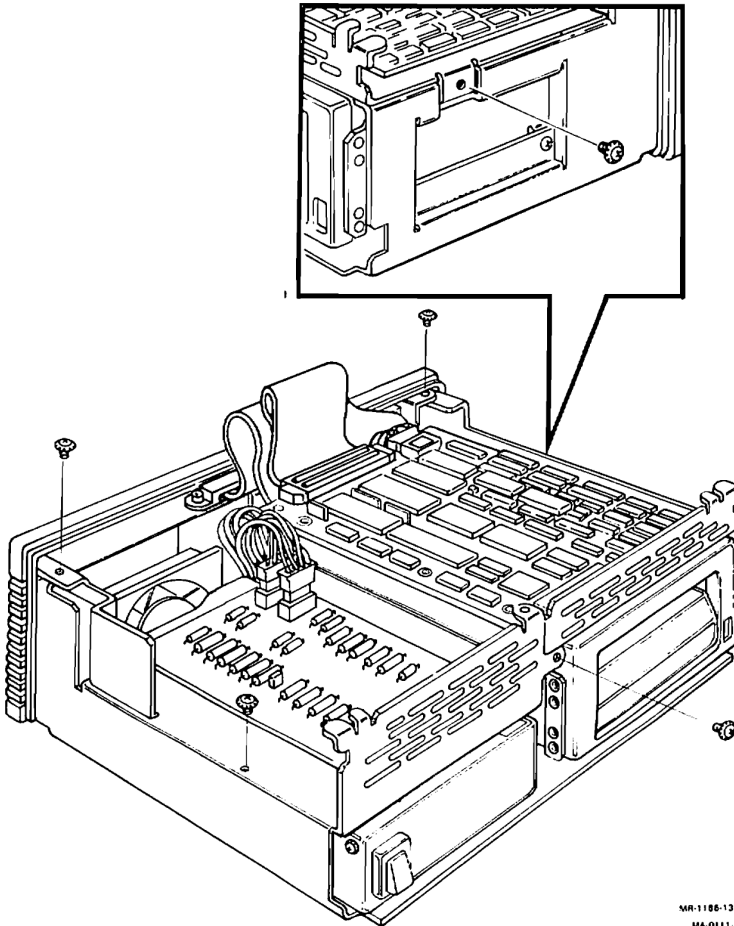

MR-1186-1313  
MA-0111-87

4. Lift the shield up and off of the main chassis.
5. Remove the three drive mounting screws shown in [Figure 3-72](#).

**Figure 3-72: Tape Drive Expansion Box Drive Mounting Screw**

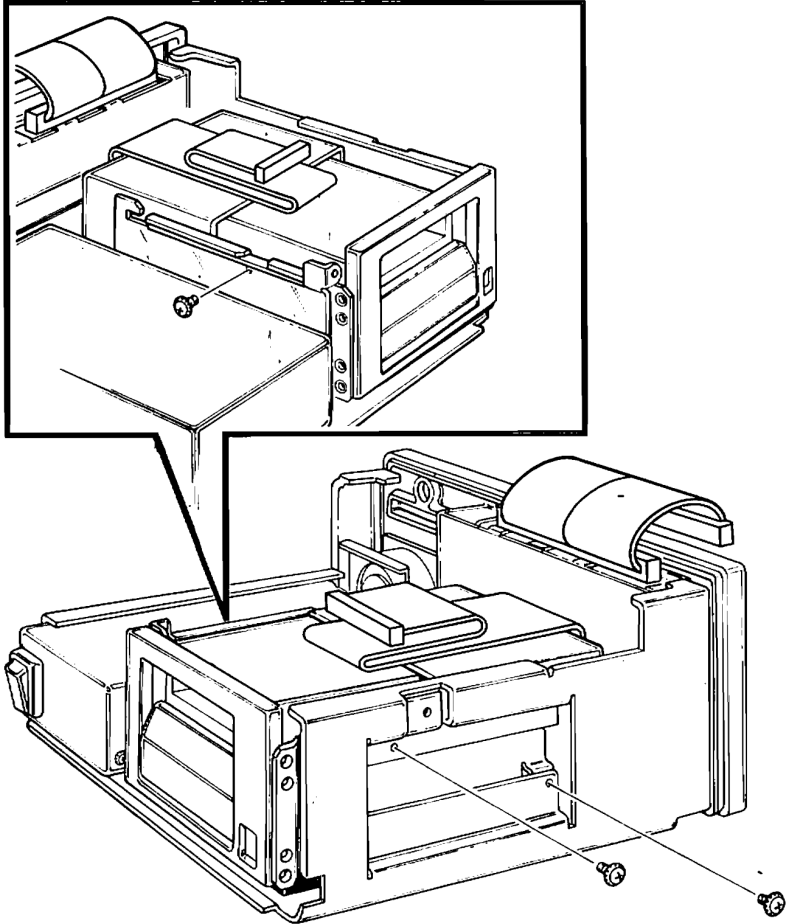

MR-1188-1314  
MA-0112-87

- Slide the tape drive out halfway and disconnect the I/O cable and the power cable from the back of the drive then remove the drive. Refer to [Figure 3-73](#).

**Figure 3-73: TK50 Tape Drive Cable Locations**

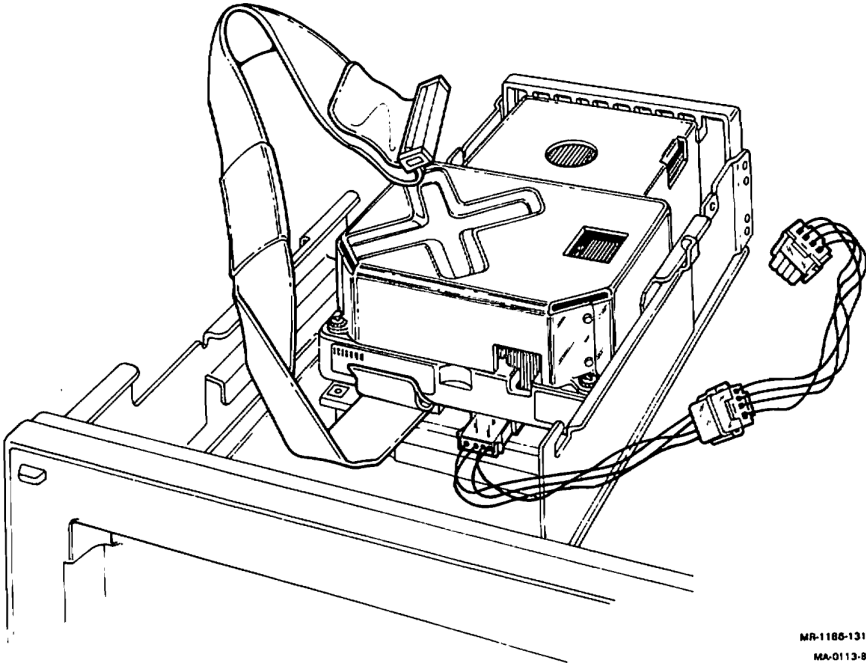

MR-1100-1315  
MA-0113-87

7. Remove the four screws shown in [Figure 3-74](#) that secure the mounting brackets to the sides of the drive. Remove the mounting brackets from the drive.

**Figure 3-74: Tape Drive Mounting Brackets Screw Locations**

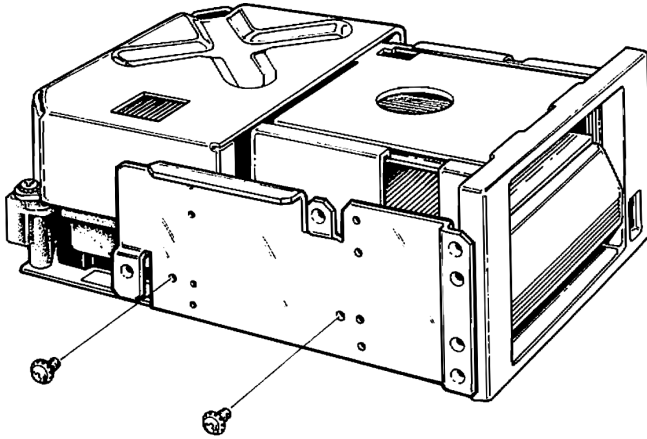

MR-1186-1318  
MA-D114-87

8. Replace the tape drive by reversing the above procedure.

### **3.17.2.3 Power Supply Removal from the Tape Drive Expansion Box**

1. Remove the TZK50 Controller board ([Paragraph 3.17.2.1](#)).
2. Disconnect the power cable on the resistor load board that comes from the power supply.
3. Unscrew the five screws shown in [Figure 3-71](#) that secure the shield to the main chassis.
4. Lift the shield up and off of the main chassis.
5. Remove the three drive mounting screws shown in [Figure 3-72](#).
6. Disconnect the power cable from the back of the drive and slide the drive out of the box.

- Put the expansion box on its side as shown in [Figure 3-75](#) and remove the four screws holding the power supply to the chassis.

**Figure 3-75: Tape Drive Expansion Box Power Supply Mounting Screw Locations**

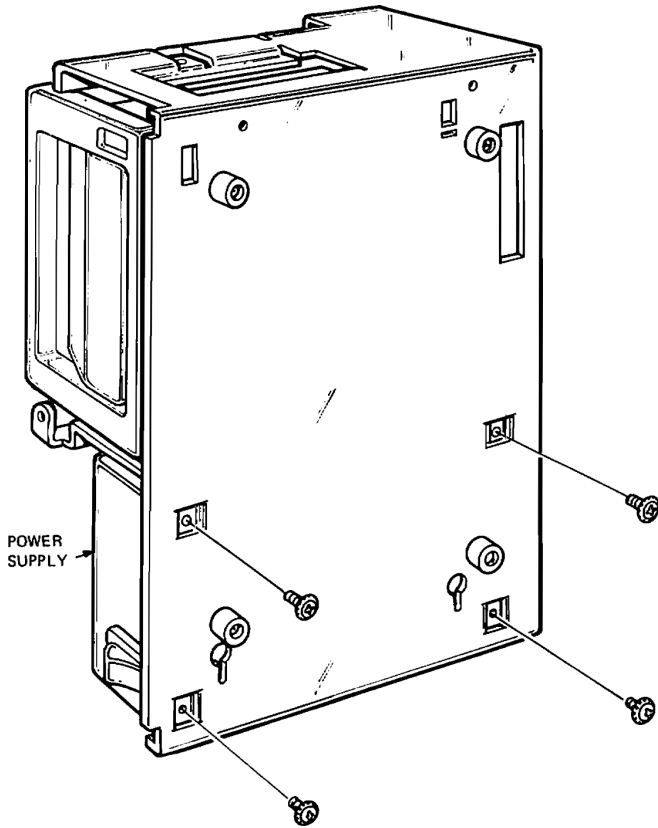

MR-1186-1317  
MA-0126-87

- Replace the power supply by reversing the above procedure.

### 3.17.2.4 Resistor Load Board Removal from the Tape Drive Expansion Box

The resistor load board in the expansion box is different from the resistor load board in the system box. The part number for the resistor load board in the expansion box is 5417163-01. The -02 version is for the system box

1. Switch off power to the expansion box.
2. Unscrew the four screws shown in [Figure 3-68](#) and remove the expansion box cover.
3. Disconnect the two power cables shown in [Figure 3-76](#) from the resistor load board.

**Figure 3-76: Tape Drive Expansion Box Resistor Load Board Power Cable Locations**

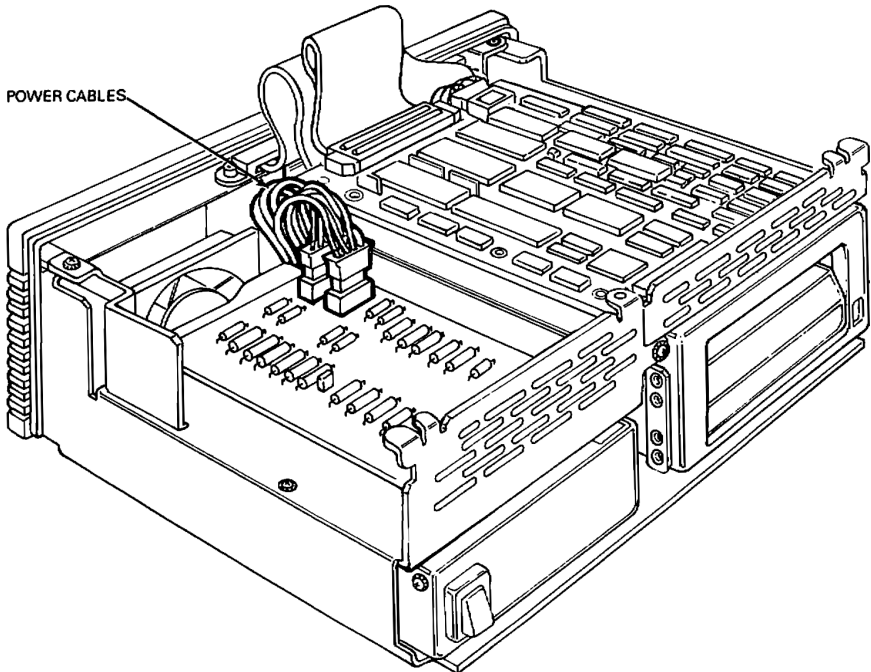

MR-1186-1318  
MA-0115-87

4. Remove the resistor load board from the shield.
5. Replace the resistor load board by reversing the above procedure.

## 3.18 Recommended Spares List

Part Number	Description	Qty
70-24268-01	VAXstation 2000 and MicroVAX 2000 System module	1
54-16802-BA	4 Megabyte memory module	1
54-16802-AA	2 Megabyte memory module	1
H7848-BA	120V power supply	1
H7848-BB	240V power supply	1
54-16804-01	Network interconnect module	1
54-17163-01	Resistor load board for Expansion Box	1
54-17163-02	Resistor load board for System Box	1
29-24794-00	9-Pin loopback connector for printer port	1
29-24795-00	25-Pin loopback connector for communication port	1
12-19245-00	Battery pack	1
54-17003-01	Disk interface module (in expansion adaptor)	1
54-17639-01	(TZK50-AA) TZK50 Controller module (in expansion box)	1
TK50-AA	TK50 tape drive	1
29-26243-00	Branch suitcase	1
17-00303-07	Network interconnect interface cable (connects network interconnect module to System module)	2
17-01107-01	Internal RX/RD cable (connects internal RX and RD drives to System module)	1
17-01107-02	RX/RD cable (connects internal RX and RD drives and also the disk interface module that is in the expansion adapter to the System module)	1
17-01244-01	Internal tape port cable (connects the tape port A inside the expansion adapter to the System module)	1
17-00674-03	RD expansion adapter cable (From the disk port B on the expansion adapter to the hard disk expansion box)	1

<b>Part Number</b>	<b>Description</b>	<b>Qty</b>
17-01247-02	TK50 tape drive I/O cable (From TK50 to TZK50 in tape drive expansion box)	1
17-01397-01	Load board power cable extension (in tape drive expansion box)	1
17-01249-01	Internal tape data cable (from TZK50 controller board to the bulkhead connector in tape drive expansion box)	1
17-01351-02	Tape drive expansion box data cable (from the tape port A on the expansion adapter to the tape drive expansion box)	1
70-23766-01	DEC423 converter (MicroVAX 2000's RS232 to DEC423 MMJ plugs converter)	1
17-00445-02	Hard disk drive expansion box data cable	1
17-00300-XX	BCC05 printer cable	1
17-00568-01	BC18P monochrome video cable	1
17-00289-XX	BCC04-10 modem cable	1
17-00301-XX	BCC08 console cable	1
17-00313-04	BC22D-50 null modem cable	1
17-00342-01	Power cable extension to resistor load board	1
17-01090-01	Internal RD data cable in expansion box	1
17-00811-03	BC16E-25 DECconnect office cable (with MMJ ends)	2
17-00811-04	BC16E-50 DECconnect office cable (with MMJ ends)	1
12-23599-01	H8571-A 25-Pin passive adapter	3
H3103	MMJ loopback connector	2
12-25869-01	ThinWire Ethernet "T" connector	1
12-26318-01	ThinWire Ethernet cable terminator	2
30-19448-06	RX50 blank media for field service system exerciser	1
30-25145-05	RX33 blank media for field service system exerciser	1
30-20515-01	TK50 blank media for field service system exerciser	1
70-21861-01	VR260 tube/yoke/bezel assembly	1
70-21862-01	VR260 LED bezel assembly	1
70-21266-01	VR260 rear bulkhead	1

<b>Part Number</b>	<b>Description</b>	<b>Qty</b>
54-15624-01	VR260 deflection board	1
54-15626-01	VR260 video amp board	1
74-30063-01	VR260 video amp board standoffs	1
70-21863-01	VR260 brightness/contrast control	1
70-21478-01	VR260 H/V cable	1
70-21480-01	VR260 ground cable	1
70-21477-01	V/D cable assembly	1
70-21865-01	VR260 transformer assembly	1
70-21924-01	VR260 chassis subset	1
74-28316-01	VR260 foot	1
12-21126-04	VR260 fuse holder assembly (Europe)	1
12-19283-19	VR260 fuse, 240 Vac (Europe)	1
90-07212-00	VR260 fuse, 115 Vac (U.S.)	1

## Video Monitor Adjustments (VAXstation 2000)

---

### 4.1 Introduction

This chapter describes how to adjust the VR260 monochrome monitor for its best picture. Alignment and adjustments for MicroVAX 2000's terminals are not covered in this guide. See the terminal's pocket service guide for all alignments to MicroVAX 2000's terminals.

### 4.2 VR260 Monochrome Monitor

Adjustments to the monitor are made with its cover removed. If the monitor's cover is not already removed, remove it ([Paragraph 3.12.1](#)) and then reconnect the power cable and the video cable to the monitor.

Follow the procedures in order. The success of one adjustment may depend on the accuracy of preceding checks and adjustments with the exception of the focus and G2 adjustments.

When the procedure tells you to display a test pattern, enter console mode ([Paragraph 2.2.2](#)), attach a loopback connector (p/n 29-24795) to the 25-pin communication port, and then type the appropriate test command listed in Table 4-1. Table 4-1 lists the base video alignment patterns and the test commands that invoke them.

**Table 4-1: Base Video Alignment Test Commands**

Test Command	Test Pattern	Loopback Required
60	Circle cross-hatch	X
61	Screen of all E's	
62	White screen pattern	

You will need the following tools to adjust the VR260 monitor.

- Alignment tool (p/n 29-24746-00)
- Metric measuring tape (p/n 29-25342)

## 4.2.1 Preparations

1. Switch on power to the VR260 monitor and the system.
2. Set the brightness and contrast controls to their maximum positions ([Figure 4-1](#)).
3. Wait 30 seconds for the monitor to warm up, then adjust the brightness to extinguish the raster.
4. Adjust the contrast for normal viewing level.

Refer to [Figure 4-2](#) for the adjustment locations on the VR260 monitor.

## **Figure 4-1: Brightness and Contrast Controls**

MISSING GRAPHIC MA-7567-83

## **Figure 4-2: VR260 Internal Adjustment Locations**

MISSING GRAPHIC MA-0116-87

### **4.2.2 Horizontal and Vertical Linearity and Focus Adjustments**

1. Display the circle cross-hatch pattern (TEST 60). If the customer is having problems with text, display the all E's pattern (TEST 61) for a reference check.

2. Adjust the horizontal linearity (UN) (use the hex trimpot) for horizontal uniformity of the squares across the display. The display should contain 32 horizontal squares and fill the screen. Refer to [Figure 4-3](#).

### **Figure 4-3: Circle Cross-Hatch Display**

MISSING GRAPHIC MA-0117-87

3. Adjust the vertical linearity (VL) (use the flat-bladed trimpot) for vertical uniformity of the squares up and down the screen. The display should contain 27 vertical squares and fill the screen.
4. Adjust the focus (use a long handled flat-blade screwdriver) for the best vertical/horizontal line sharpness. Check an intersection of the crosshatch pattern that is at least three squares in from any one of the four corners.

### 4.2.3 Width, Height, and Centering Adjustments

1. Display the white screen display (TEST 62).
2. Adjust the brightness so the raster is visible.
3. Adjust the contrast for normal viewing level.
4. Adjust horizontal centering (H CENT) (use the flat-blade screwdriver) until the raster is centered.
5. Adjust the horizontal phase (HP) so the video is centered in the raster.
6. Adjust the brightness to extinguish the raster.
7. Measure the width of the display with the tape measure as shown in [Figure 4-4](#). The display should have a 334 mm width. Adjust width (use the hex trimpot) until the display measures 334 mm across.

**CAUTION:** *Avoid scratching the screen surface with the metal clip of the tape. Start the measurement at 10 cm (100 mm) as shown below.*

#### Figure 4-4: Width and Height Measurements

MISSING GRAPHIC MA-0756-85

8. Adjust the vertical height (VH) and the vertical centering (VC) so that the display touches the top and bottom edges of the screen at the same time.
9. Measure the height of the display with the tape measure. The display should have a 282 mm height. Adjust the vertical height (VH) until the display measures 282 mm top to bottom.

#### 4.2.4 Rechecking the Display

1. Display the circle cross-hatch pattern (TEST 60).
2. Check the vertical and horizontal linearity of the Squares. Readjust if needed ([Paragraph 4.2.2](#), steps 2 and 3).
3. Check the vertical and horizontal centering, the height, and the width of the display. Readjust if needed ([Paragraph 4.2.3](#)).

#### 4.2.5 Adjusting Minimum Raster

1. Set the brightness to maximum and the contrast to minimum. A raster should be faintly visible.
2. If no raster is visible, adjust G2 (use a flat-blade screwdriver) until a raster is faintly visible.
3. Adjust the brightness and contrast for normal viewing.

#### 4.2.6 Reassembling the VR260 Monitor

1. Switch the System power switch and the monitor power switch off.

**WARNING:** *Wait at least 30 seconds after you turn off power to unplug the power cord. Static electricity dissipates for 30 seconds after power is turned off.*

2. Disconnect the power cord and the video cable from the monitor.
3. Reverse the procedure in [Paragraph 3.12.1](#).



# Index

---

## A

---

Alignment Pattern	
Circle Cross-hatch	2-58
Screen of E's	2-58
White Screen	2-58

## B

---

Battery Testing	
See Troubleshooting, NVR	
Baud Rate	
Console Device	2-2
Diagnostic Console	2-4
BCC08 Cable	2-2, 2-4